

FEATURES:

- Painted hood and panels match factory specifications and color.
- Fully insulated panel (Insulation: 1"-1.5 lb. Density).
- Estimated Weight: 22 Lbs.

0 - 25% OUTSIDE AIR PACKAGE FOR ALLIED UNITS

KGA, KCA, KHA 092-150S

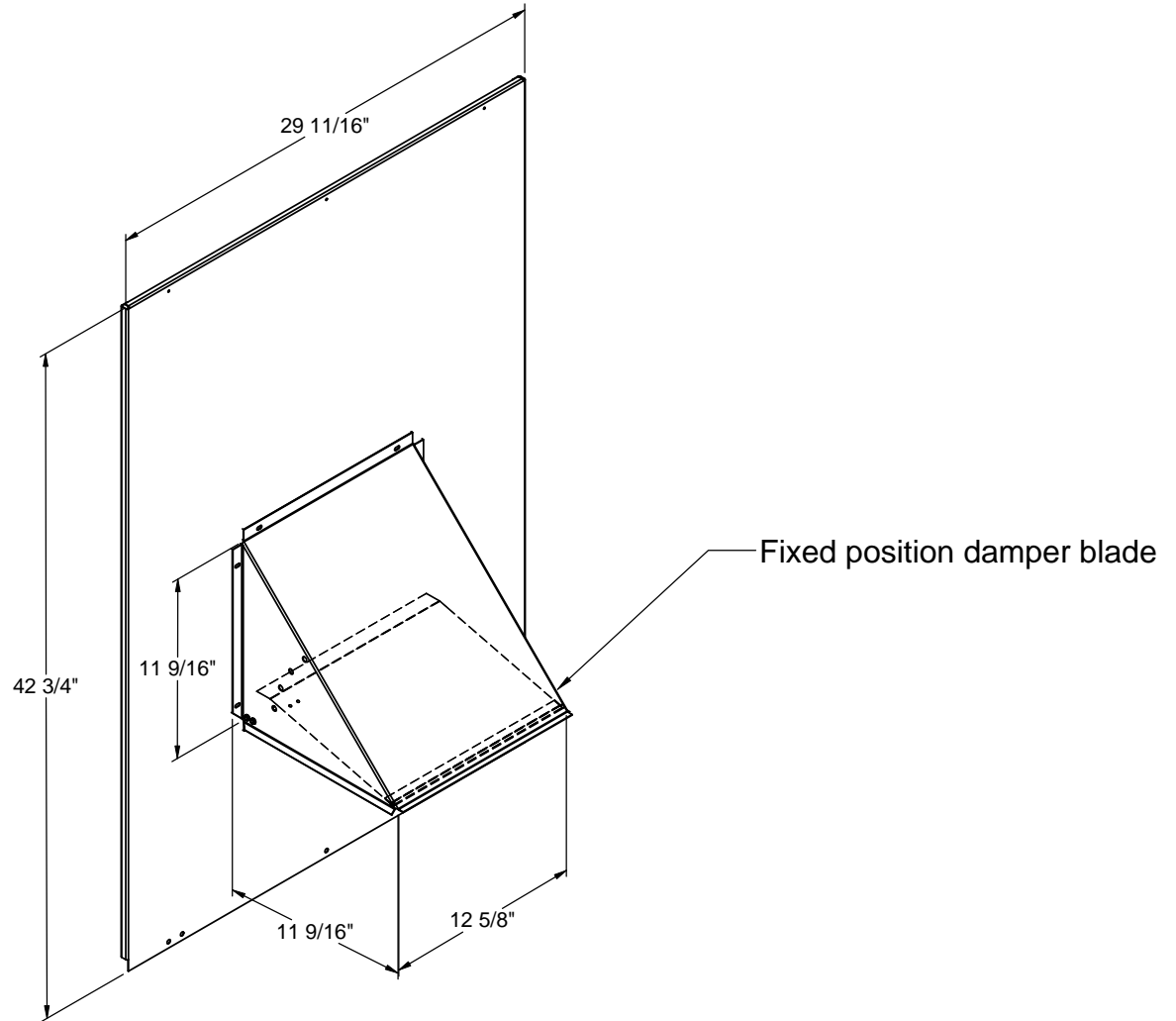

3847 WABASH DRIVE
MIRA LOMA, CA 91752

PHONE (951) 685-1101
FAX (619) 872-9799

SUBMITTED TO: _____
COMPANY: _____
JOB NAME: _____
EQUIPMENT: _____
NOTES: _____

FORM NO:
-

PART NUMBER:
OABBX25

DATE:
1/11/2013

REV:
-

DRAWN BY:
CNG