

PLEASE NOTE: This instruction provides the necessary information to properly field- install the economizer assembly on 2 ton through 5 ton single package rooftop units.

The damper accessory provides the return air and outdoor air dampers and actuator for the economizer operations. Contained in this kit are all rain hood components.

PLEASE NOTE: If the unit is 208/230V, single phase, power supply, the installed 40VA transformer needs/must be replaced with a 75VA transformer. All other factory units have the 75VA transformer installed standard.

Before Starting Installation

Warning

Shut power to unit prior to any work being done. Personal injury or death could result.

Only qualified HVAC service personnel should install, troubleshoot, repair or service HVAC and related HVAC equipment.

Installation of Cooling Only & Heat Pumps

1. Disconnect the power supply.
2. Remove the filter access door. **(ILL. 2)**
3. Remove screws in immediate area on mid pan. **(ILL. 3)**
4. Remove top plate of economizer assembly. **(ILL. 4)**
5. Before installing economizer into the unit, make sure the duct cover has been removed. **(ILL.5)** Place the economizer into the unit and support the economizer from underneath until step 6 is complete. Place gasket as needed.
6. Replace top panel of economizer assembly, with front flange under mid pan and place screws back into place. **(ILL. 6)**
 - 6a. **Only for 4 & 5 Ton Units-** Use the side door provided to close gap between economizer and compressor panel.
7. Replace screws in mid pan to secure economizer to unit.
8. Drill a 1/2" hole in compressor barrier as needed to route wiring to main control board and sensors. Tightly seal opening around wires.
9. Route wiring through existing openings to control panel.

PARTS INCLUDED	QTY.
#10 x 1/2 Sheet Metal Screw	12
Terminal Block with Wire Harness	1
Tie Wraps	5
Gasket 1/8" x 1/2"	6 ft.
Gasket 3/4"x 1-1/4"	7 ft.
Discharge Air Sensor	1

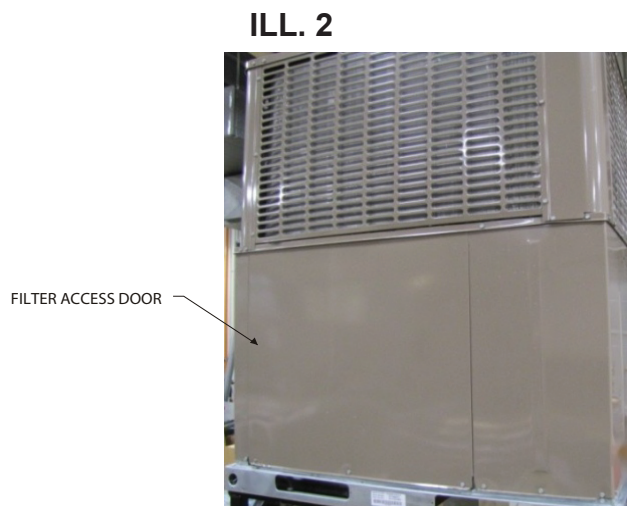
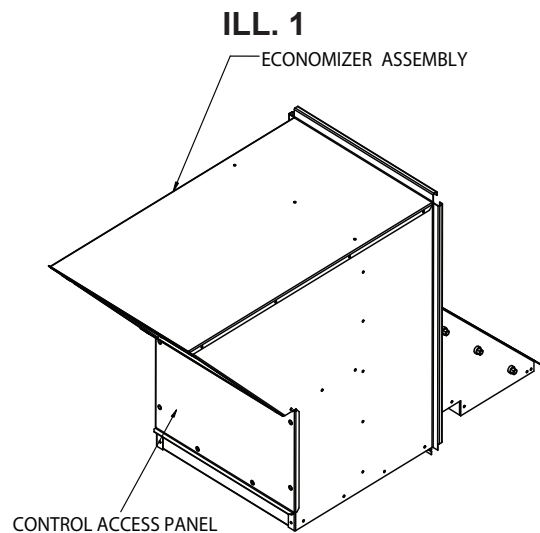

ILL. 3



ILL. 4

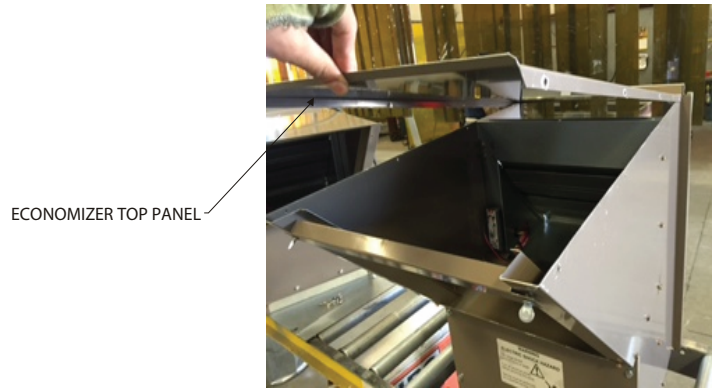

MID PAN

ECONOMIZER TOP PANEL

ILL. 6

FRONT FLANGE



ILL. 5



DUCT COVER

ILL. 7



BOTTOM DUCT OPENING

ILL. 8



ILL. 9

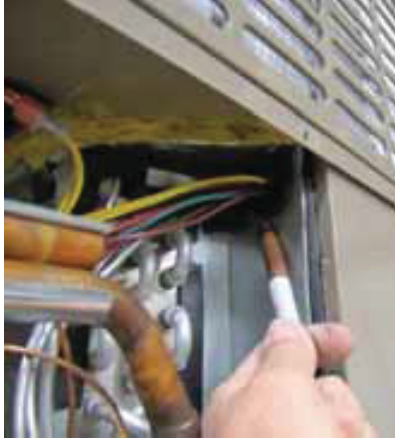

ILL. 10

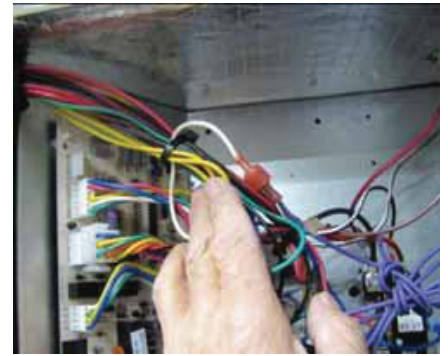

10. The discharge air sensor should be mounted on the blower wheel wrap. Use only #8 screws shorter than 1/2" in length to avoid hitting blower wheel.
11. For economizers with optional power exhaust, route the power cord through the unit following step 8 and 9. See wiring diagram notes (ILL. 16- ILL. 20) and follow all electrical codes for connection.

ILL. 11

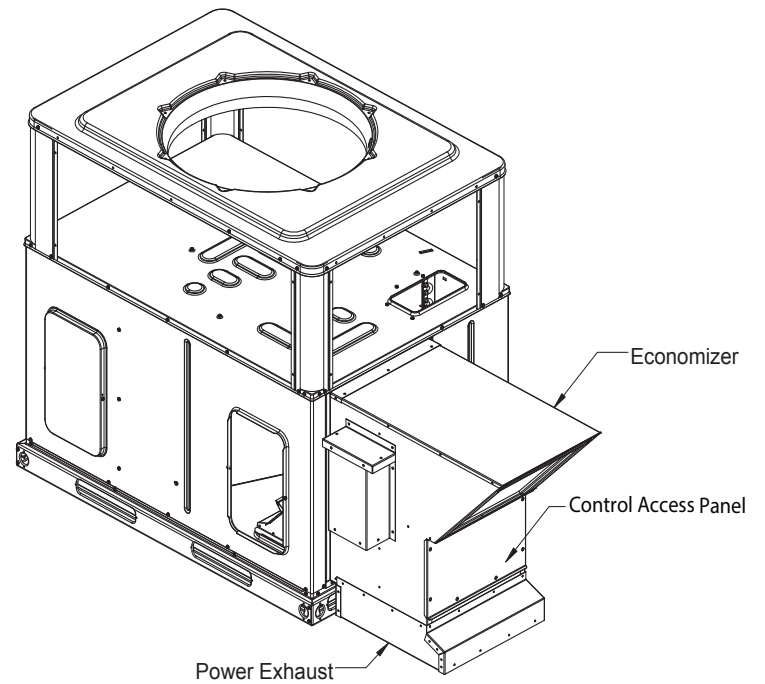

ILL. 12

Dry Bulb Gas Electric Control Wiring Diagram

LX ECONOMIZER
DRY BULB CONTROL WIRING DIAGRAM
GAS ELECTRIC

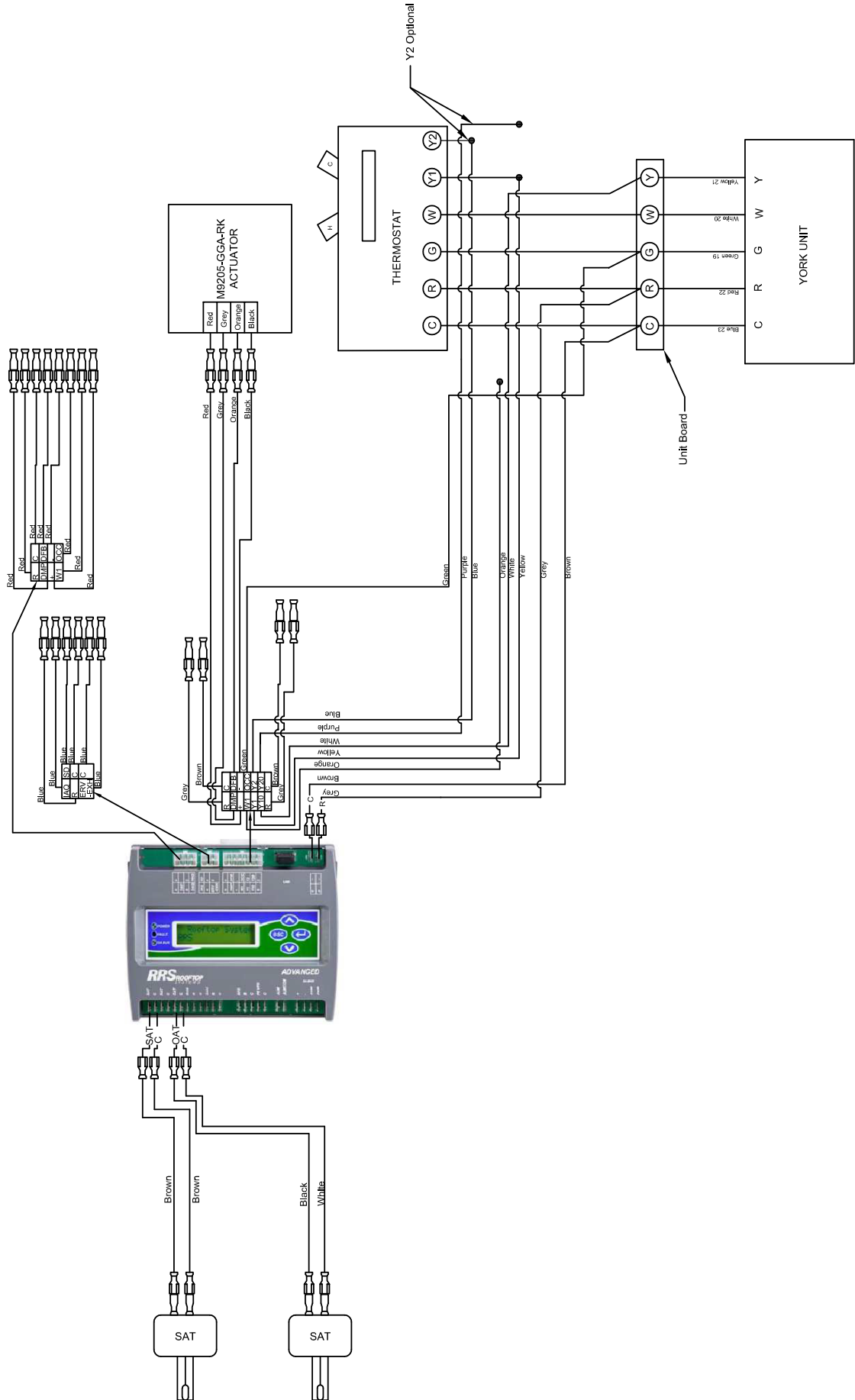

ILL. 13
 Enthalpy Gas Electric Control Wiring Diagram

LX ECONOMIZER
 ENTHALPY CONTROL WIRING DIAGRAM
 GAS ELECTRIC

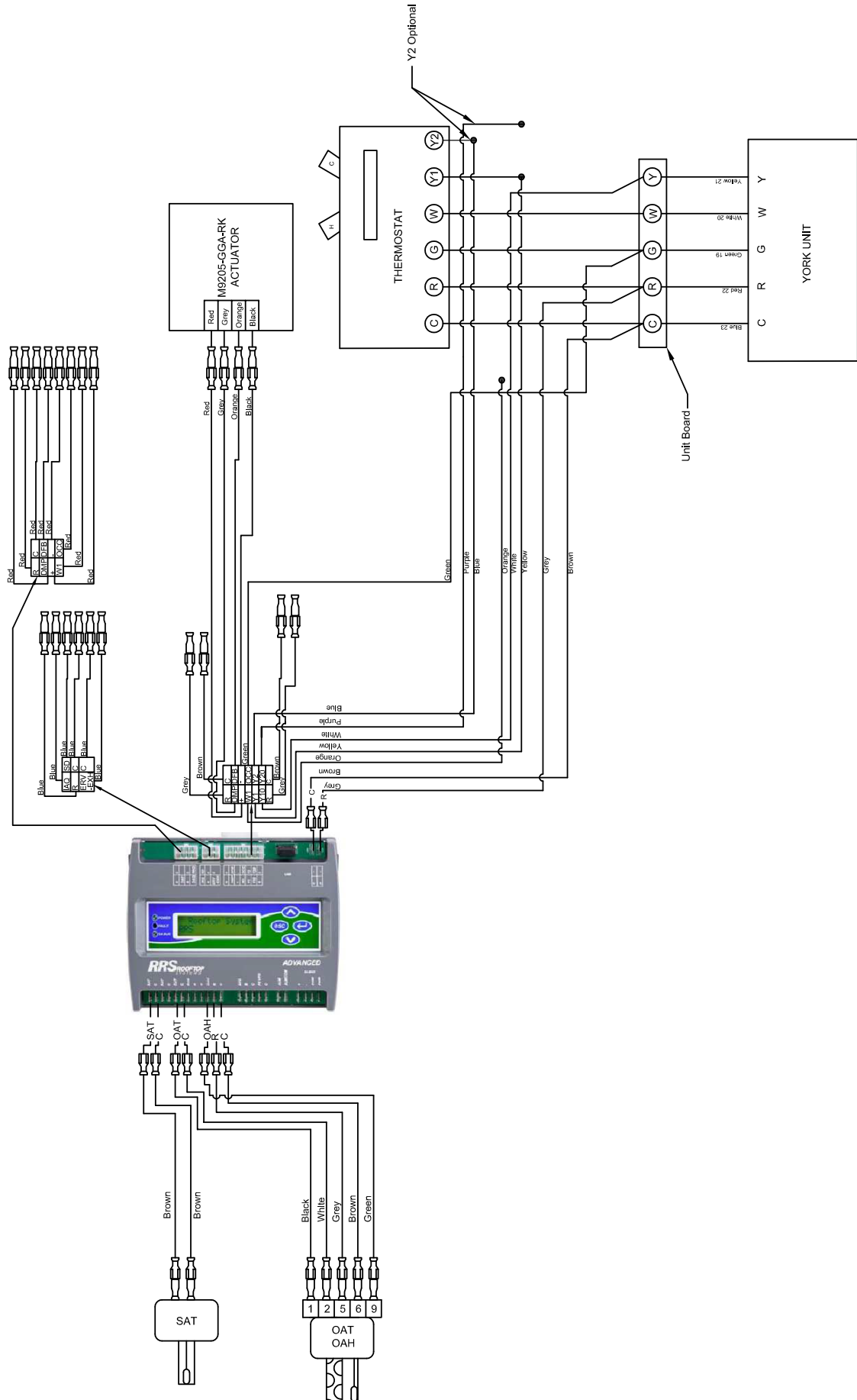

ILL. 14 Dry Bulb Heat Pump Control Wiring Diagram

LX ECONOMIZER
DRY BULB CONTROL WIRING DIAGRAM
HEAT PUMP

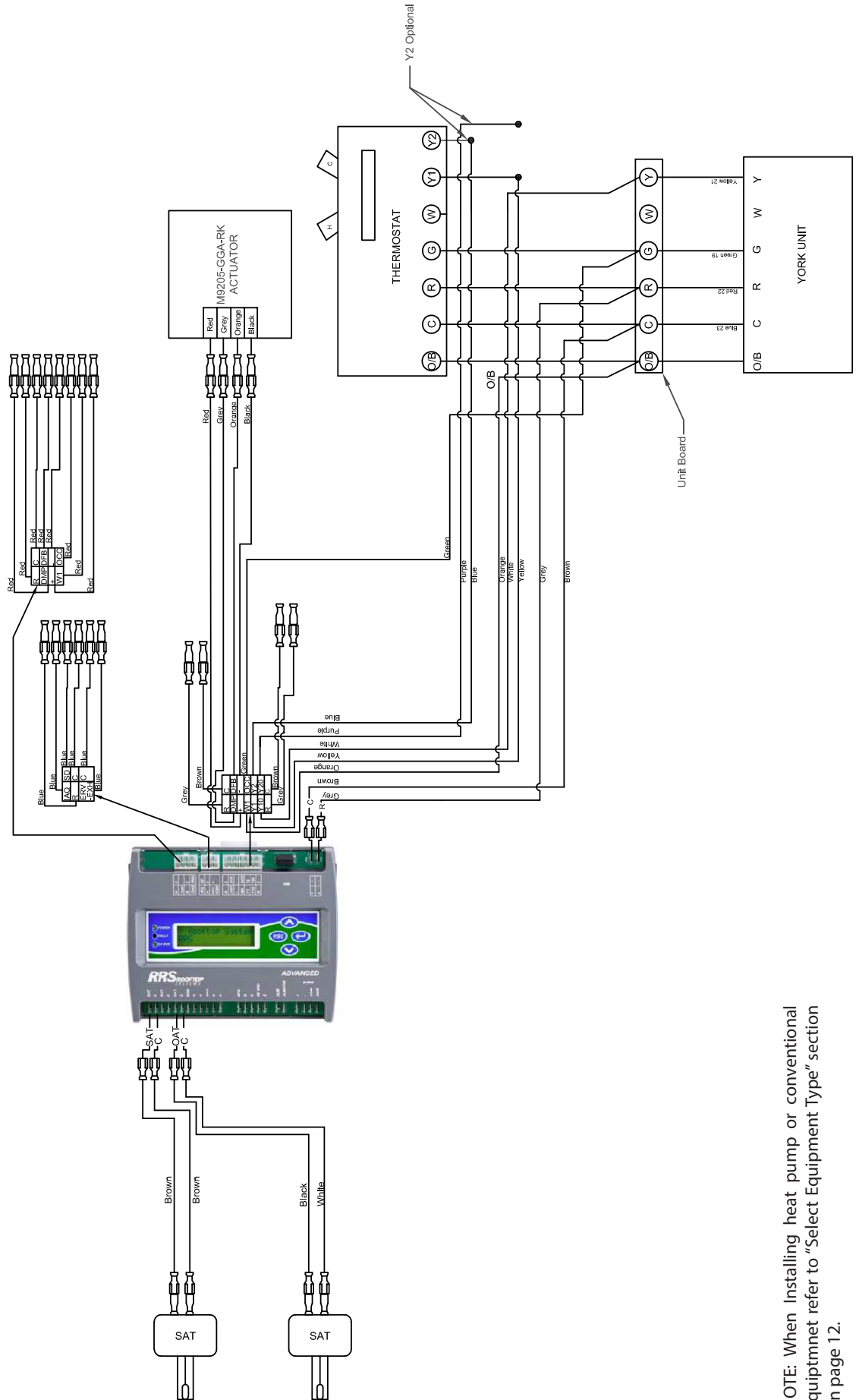

NOTE: When installing heat pump or conventional equipment refer to "Select Equipment Type" section on page 12.

ILL. 15
 Enthalpy Heat Pump Control Wiring Diagram

LX ECONOMIZER
 ENTHALPY CONTROL WIRING DIAGRAM
 HEAT PUMP

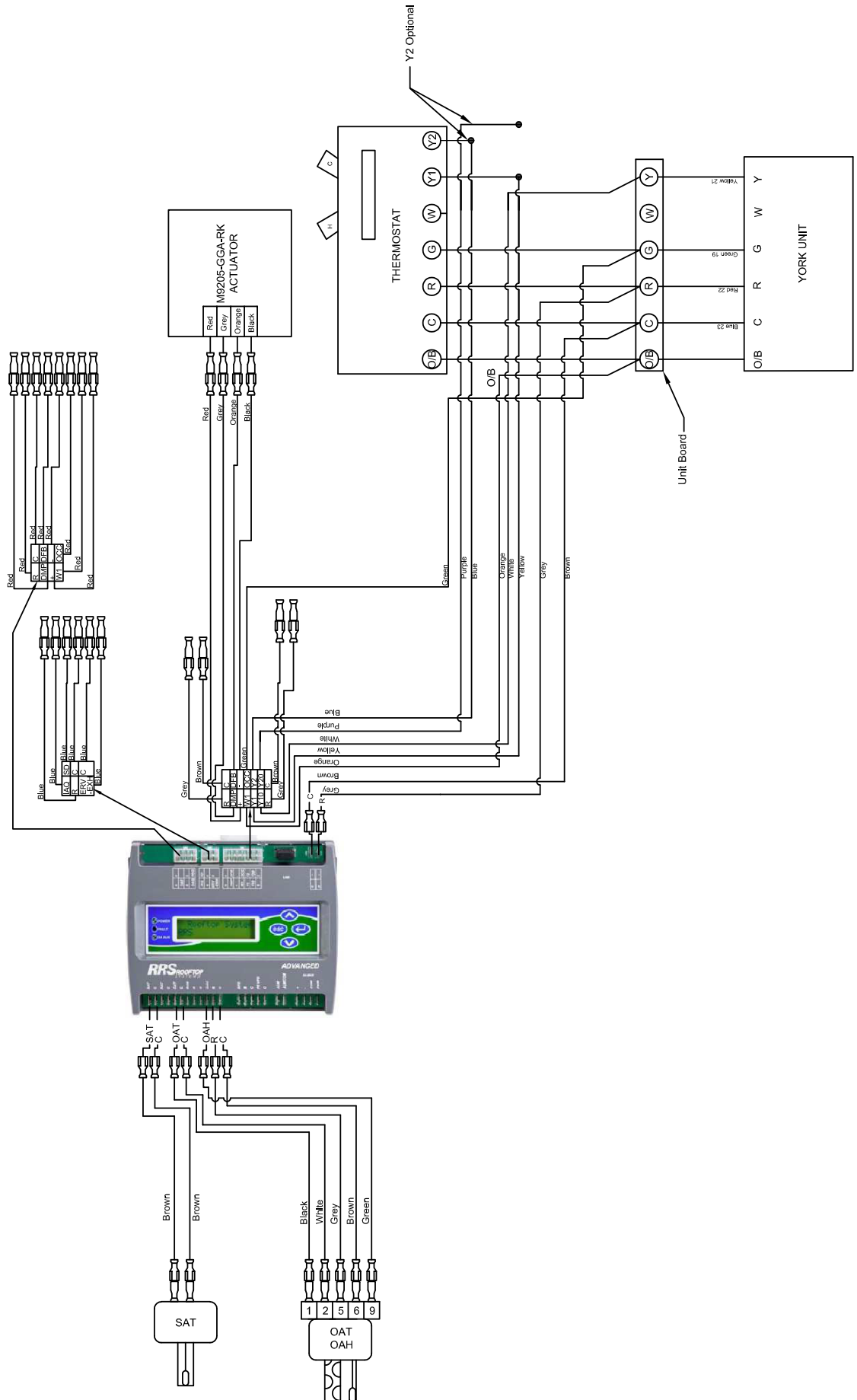

Table 1: Economizer Controller Terminations

Board Name ¹	Description	Type	Termination Type
Analog Inputs (AIs)			
SAT	Supply Air Temperature, C	Resistive	Spade
RAT	Return Air Temperature, C	Resistive	Spade
OAT	Outdoor Air Temperature, C	Resistive	Spade
OAH	Outdoor Air Humidity, R, C	0 to 10 V	Spade
RAH	Return Air Humidity, R, C	0 to 10 V	Spade
IAQ	Indoor Air Quality Input, R, C	0 to 10 V	Pin Connector
BPS*	Bldg Pressure Input, R, C	0 to 10 V	Spade
OAF*	Outdoor Air Flow, R, C	0 to 10 V	Pin Connector
OAQ*	Outdoor Air Quality, R, C	0 to 10 V	Pin Connector
DFB	Damper Feedback Position, C	0 to 10 V	Pin Connector
Analog Outputs (AOs)			
DMP	Damper Output	0 to 10 V	Pin Connector
PE VFD*	PE VFD Output, C	0 to 10 V	Spade
Binary Inputs (BIs)			
Y1O	Y1 Status	24 VAC	Pin Connector
Y2O	Y2 Status	24 VAC	Pin Connector
W1	W1 Status or O/B Status	24 VAC	Pin Connector
SD	Shutdown Status	24 VAC	Pin Connector
PRG*	Purge Status	24 VAC	Pin Connector
OCC	OCC Status	24 VAC	Pin Connector
Binary Outputs (BOs)			
ALM	Alarm Output, Output COM	Relay (dry contact)	Spade
Y1O	Y1 Output	Relay (24 VAC)	Pin Connector
Y2O	Y2 Output	Relay (24 VAC)	Pin Connector
ERV-EXH	Exhaust Fan/ERV Output	Relay (24 VAC)	Pin Connector
Additional Terminations			
R	R (24 VAC Class 2 Supply)	24 VAC	Spade
Board Name¹	Description	Type	Termination Type
C	C (24 VAC Class 2 Common)	24 VAC	Spade
SA Bus*	SA Bus	RS-485 Comm	Spade

1. The * denotes the Inputs and Outputs (I/Os) are only on the Advanced model.

Accessories

Table 2: Accessories

Product Code Number	Description
TE-636GV-2	Temperature Sensor
HE-6862-0N00WS	Temperature/Humidity Sensor
M9205-GGA-YK10	Damper Actuator
CD-W00-x0-1	Space CO ₂ Sensor (recommended)
CD-Pxx-00-0	Duct CO ₂ Sensor (recommended)
RK-WRH1001-0	Wiring Harness

Note: For Outdoor Air (OA) Flow monitoring consult your local Johnson Controls branch or RRS representative to determine the best product to use for your application. Due to the various sensors available for monitoring OA flow, we cannot recommend one specific product.

ILL. 16 - Optional Modulating Power Exhaust Wiring Diagram 230V/1Ph

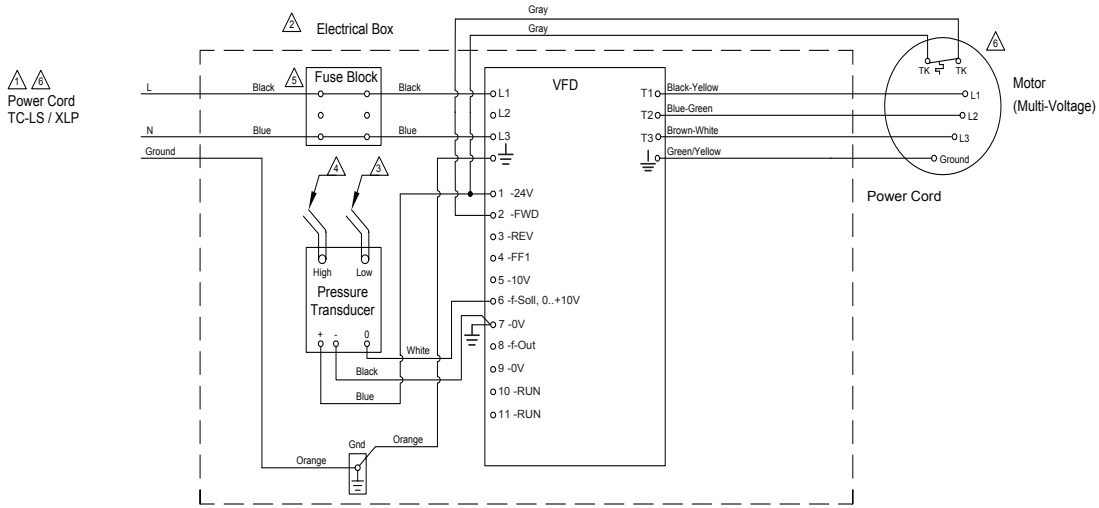

⚠ Power Supply. Provide disconnect means and circuit protection as required. See power exhaust name plate for electrical ratings. If local codes allow connecting to the HVAC unit power, make sure the disconnect and incoming wiring are sized to handle the load of both the HVAC unit and the power exhaust.

To determine MCA with power exhaust: $\text{New MCA} = \text{MCA of Unit Only} + \text{MCA of Power Exhaust}$

- ⚠** Transformer, contactor and fuses to be in a NEMA type electrical enclosure.
- ⚠** Factory mounted 3/16" low pressure tubing.
- ⚠** 25 feet of 3/16" high pressure tubing and connection port provided for field mounting in conditioned space. Architectural finishing field provided. (Follow local codes.)
- ⚠** For fuse size, refer to label on exterior of power exhaust cabinet.
- ⚠** For voltage, refer to label on exterior of power exhaust cabinet.

ILL. 17 - Optional Modulating Power Exhaust Wiring Diagram 230V/3Ph

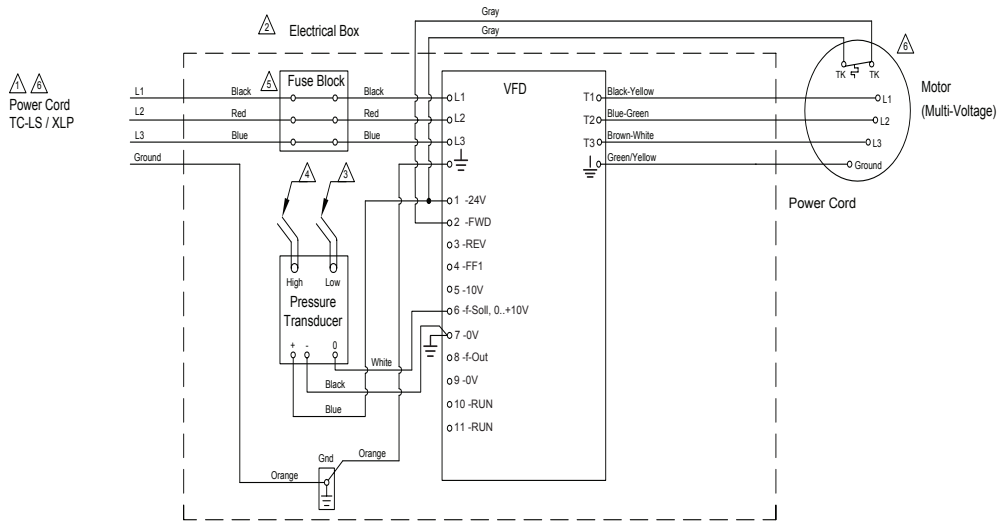

⚠ Power Supply. Provide disconnect means and circuit protection as required. See power exhaust name plate for electrical ratings. If local codes allow connecting to the HVAC unit power, make sure the disconnect and incoming wiring are sized to handle the load of both the HVAC unit and the power exhaust.

To determine MCA with power exhaust: $\text{New MCA} = \text{MCA of Unit Only} + \text{MCA of Power Exhaust}$

- ⚠** Transformer, contactor and fuses to be in a NEMA type electrical enclosure.
- ⚠** Factory mounted 3/16" low pressure tubing.
- ⚠** 25 feet of 3/16" high pressure tubing and connection port provided for field mounting in conditioned space. Architectural finishing field provided. (Follow local codes.)
- ⚠** For fuse size, refer to label on exterior of power exhaust cabinet.
- ⚠** For voltage, refer to label on exterior of power exhaust cabinet.

ILL. 18 - Optional Modulating Power Exhaust Wiring Diagram 460V/3Ph

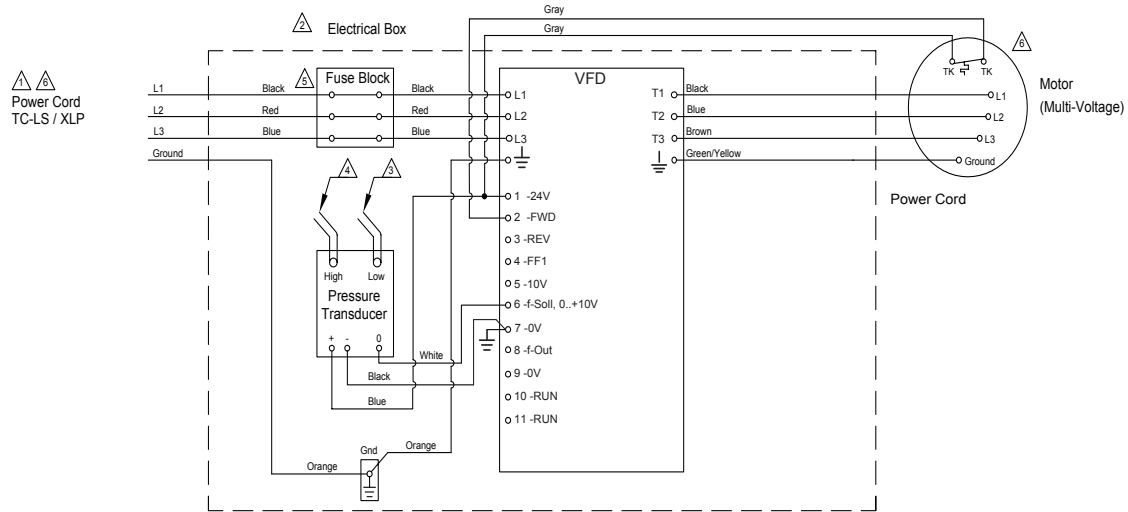

- ⚠ Power Supply. Provide disconnect means and circuit protection as required. See power exhaust name plate for electrical ratings. If local codes allow connecting to the HVAC unit power, make sure the disconnect and incoming wiring are sized to handle the load of both the HVAC unit and the power exhaust.

To determine MCA with power exhaust: $\text{New MCA} = \text{MCA of Unit Only} + \text{MCA of Power Exhaust}$

- ⚠ Transformer, contactor and fuses to be in a NEMA type electrical enclosure.
- ⚠ Factory mounted 3/16" low pressure tubing.
- ⚠ 25 feet of 3/16" high pressure tubing and connection port provided for field mounting in conditioned space. Architectural finishing field provided. (Follow local codes.)
- ⚠ For fuse size, refer to label on exterior of power exhaust cabinet.
- ⚠ For voltage, refer to label on exterior of power exhaust cabinet.

ILL. 19 - Optional Constant Volume Power Exhaust Wiring Diagram 230- 460V/3Ph

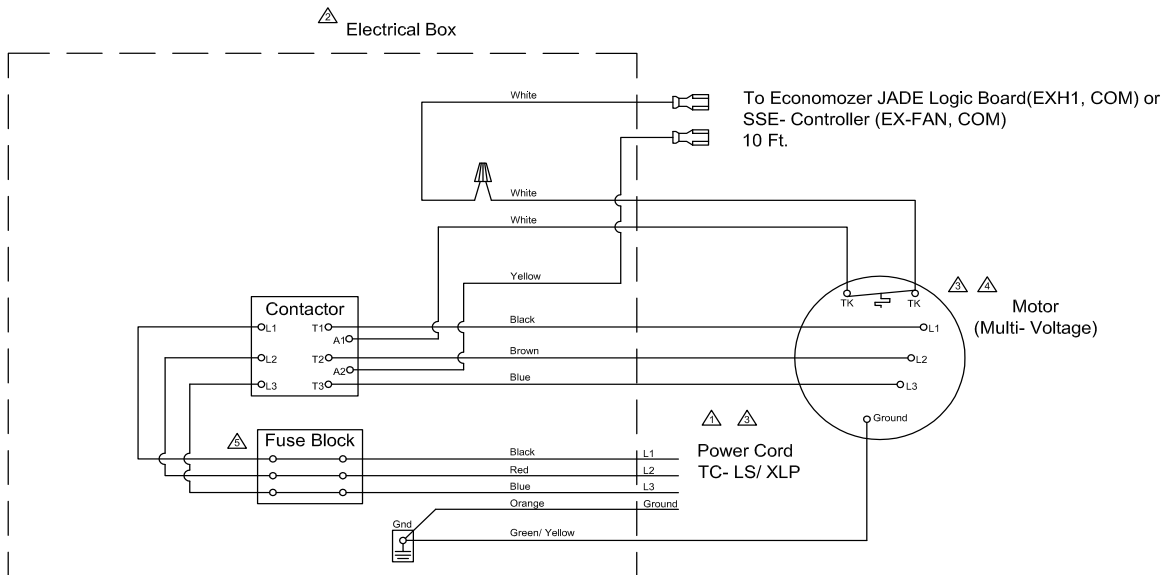

- ⚠ Power Supply. Provide disconnect means and circuit protection as required. See Power Exhaust name plate for electrical ratings. If local codes allow connecting to the HVAC unit power, make sure the disconnect and incoming wiring are sized to handle the load of both the HVAC unit and Power Exhaust.

To determine MCA with power exhaust: $\text{New MCA} = \text{MCA of Unit Only} + \text{MCA of Power Exhaust}$.

- ⚠ Transformer, Contactor, and Fuses are to be in a NEMA type electrical enclosure.
- ⚠ For Voltage, refer to label on the exterior of power exhaust cabinet.
- ⚠ Motor supplied with internal thermal protection.
- ⚠ 1 amp LPCC fuses (460-3Ph). 2 amp LPCC fuses (230V- 3Ph). 3 amp LPCC fuses (230- 1Ph).

ILL. 20 - Optional Constant Volume Power Exhaust Wiring Diagram 230V/1Ph

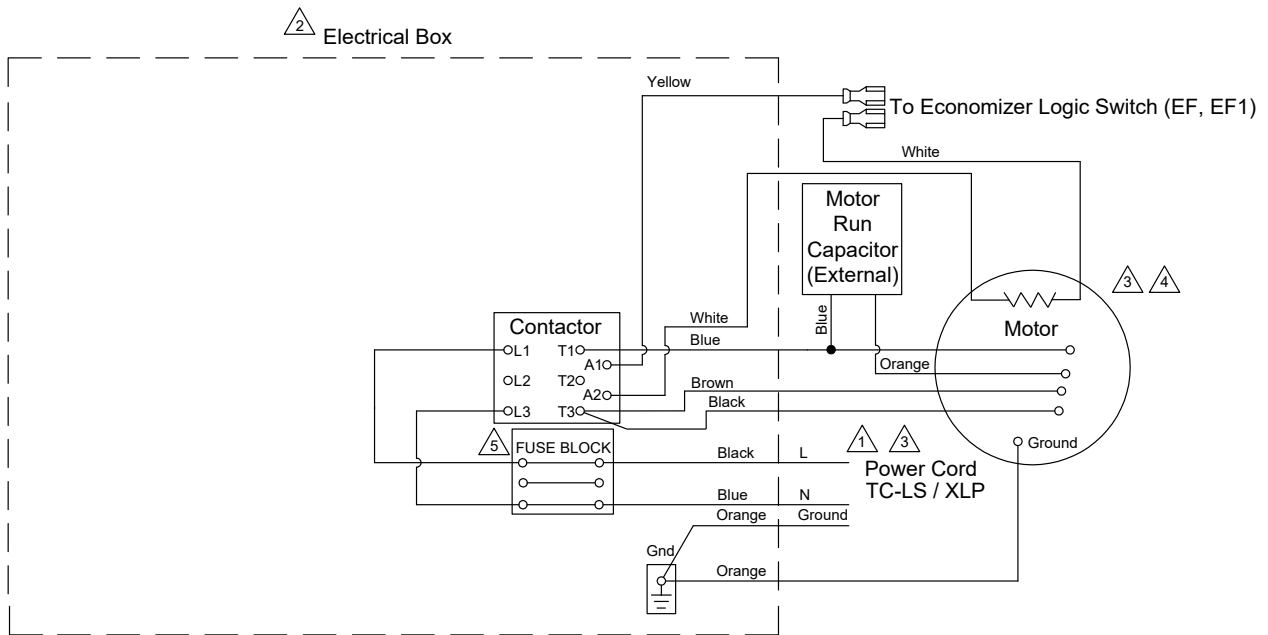

- 1 Power Supply. Provide disconnect means and circuit protection as required. See power exhaust name plate for electrical ratings. If local codes allow connecting to the HVAC unit power, make sure the disconnect and incoming wiring are sized to handle the load of both the HVAC unit and the power exhaust.

To determine MCA with power exhaust: $\text{New MCA} = \text{MCA of Unit Only} + \text{MCA of Power Exhaust}$

- 2 Transformer, contactor and fuses are to be in a NEMA type electrical enclosure.
- 3 For voltage, refer to label on exterior of power exhaust cabinet.
- 4 Motor supplied with internal thermal protection.
- 5 For fuses, refer to label on exterior of power exhaust cabinet.

Table 3: Economizer controller terminations

Name	Description	Type	Termination Type
Analog Inputs (AIs)			
SAT	Supply Air Temperature, C Sensor product code: TE-636GV-2	Resistive	Spade
RAT	Return Air Temperature, C Sensor product code: HE-69630NS-2	Resistive	Spade
OAT	Outdoor Air Temperature, C Sensor product code: HE-69630NS-2	Resistive	Spade
OAH	Outdoor Air Humidity, R, C Sensor product code: HE-69630NS-2	0 VDC to 10 VDC	Spade
RAH	Return Air Humidity, R, C Sensor product code: HE-69630NS-2	0 VDC to 10 VDC	Spade
IAQ	Indoor Air Quality Input, R, C Sensor product code: CD-W00-00-2	0 VDC to 10 VDC	Pin Connector
BPS	Building Pressure Input, R, C	0 VDC to 10 VDC	Spade
OAF	Outdoor Air Flow, R, C	0 VDC to 10 VDC	Pin Connector
OAQ	Outdoor Air Quality, R, C Sensor product code: CD-P1000-00-00	0 VDC to 10 VDC	Pin Connector
DFB	Damper Feedback Position, C	0 VDC to 10 VDC, or 2 VDC to 10 VDC	Pin Connector
Analog Outputs (AOs)			
DMP	Damper Output Damper actuator product code: M9205-GGA-EC01	0 VDC to 10 VDC, or 2 VDC to 10 VDC	Pin Connector
PE VFD	PE VFD Output, C	0 VDC to 10 VDC	Spade

Table 3: Economizer controller terminations

Name	Description	Type	Termination Type
Binary Inputs (BIs)			
Y1	Y1 Status	24 VAC	Pin Connector
Y2	Y2 Status	24 VAC	Pin Connector
W1	W1 Status or O/B Status	24 VAC	Pin Connector
SD	Shutdown Status	24 VAC	Pin Connector
PRG	Purge Status	24 VAC	Pin Connector
OCC	OCC Status	24 VAC	Pin Connector
Binary Outputs (BOs)			
ALM	Alarm Output, Alarm COM	Relay (dry contact)	Spade
Y1O	Cooling Stage 1	Relay (24 VAC)	Pin Connector
Y2O	Cooling Stage 2	Relay (24 VAC)	Pin Connector
ERV-EXH	Exhaust Fan/ERV Output	Relay (24 VAC)	Pin Connector
Additional Terminations			
R	R (24 VAC Class 2 Supply)	24 VAC	Spade and Pin Connector
C	C (24 VAC Class 2 Common)	24 VAC	Spade and Pin Connector
SA Bus	SA Bus	RS-485 Comm	Spade

Accessories

Table 4: Accessories

Product code number	Description
TE-636GV-2	Duct temperature sensor
HE-69630NS-2	Temperature and humidity sensor
TE-6363P-1	Outside air temperature sensor
M9205-GGA-EC01	Damper actuator
CD-W00-00-2	Space CO ₂ sensor ⓘ Note: It is best practice to install this sensor.
CD-P1000-00-00	Duct CO ₂ sensor
RK-WRH1001-0	Wiring harness
NSB8BTN241-0	Zone temperature sensor with fault code display capability, no logo, white
NSB8BTN243-0	Zone temperature sensor with fault code display capability, no logo, black

Powering the unit

When you apply 24 VAC power to the C and R terminals (on the upper right side of the unit), the controller begins a start-up sequence.

During the start-up sequence, the LCD displays a start-up text and a countdown. The buttons are **not** functional. The following table shows the status of the LEDs during the start-up sequence.

Table 5: LED status during start-up

LED	Status
Power (green)	On steady if the C and R terminals receive power
Fault (red)	Blink
SA Bus (green)	For approximately 10 seconds: On steady After approximately 10 seconds: <ul style="list-style-type: none"> • Blink: Normal communication • On steady: Communication lost

After the start-up sequence finishes, the display is blank on both lines if no alarm is active. The red Fault LED turns off.

Menu structure

The following section describes the menus and submenus for the RRS Economizer controller. The Level 1 menus are the following:

- Setup
- Status
- Advanced Setup
- Advanced Status
- Controller
- Update
- Self Test
- View Results

Each menu and the submenus are detailed below.

- ⓘ **Note:** The parameters that appear in your menu are based on the equipment configuration. See Table 16 for a list of the conditions that determine whether a menu item is visible.

Understanding the local LCD

After you apply power to your rooftop unit (RTU), a start-up countdown begins on the Economizer LCD. When the controller is ready, the screen is blank to indicate that no faults are present. Use the push buttons next to the LCD to navigate through the menus.

Figure 10: LCD and buttons on the Economizer



Each menu item is either a submenu or a property. To move the cursor, press the up and down arrow buttons. To select an item, press the right arrow button. To go back to the previous item, press the left arrow button.

To modify the value of a property, press the right arrow button to select the property, and then press the up and down arrow buttons to select a new value.

Setup menu

Table 6: Setup menu

Level 2 on MAP Gateway (on LCD)	Default values	Available values
Language	English	English, French, Spanish
Install Month	1	1 to 12
Install Day	1	1 to 31
Install Year	2019	2015 to 2030
Units	IP	IP, SI
Equipment Type	Conv RTU	Conv RTU, Heat Pump
Thermostat Type	W	W, B, O
Number of Cooling Stages Installed (Comp Stages)	1	1 to 2
Fan Control Type	Single Speed	Single Speed, Two Speed
Dry Bulb Setpoint (Dry Bulb Stpt)	68°F	35°F to 86°F
Economizer Outdoor Air Enthalpy Setpoint (OA Enth Setpt)	27 BTU/lb Dry Air	10 BTU/lb to 50 BTU/lb Dry Air
Economizer Minimum Position Setpoint (Damper Min Pos)	10%	0% to 100%
Economizer Damper Minimum Position Low Speed Fan (Low Spd Min Pos)	45%	0% to 100%
Exhaust Setup	None	None, Non-modulating Control, Variable Frequency Fan, ERV
Economizer Damper Position for Exhaust Fan to Turn On (Damper % Fan On)	60%	0% to 100%
Economizer Damper Position for Exhaust Fan to Turn Off (Damper % Fan Off)	20%	0% to 100%
Damper Position for Exhaust Fan to Turn Off Low Speed Fan (Damper % Fan Off Lo Spd)	40%	0% to 100%
Damper Position for Exhaust Fan to Turn On Low Speed Fan (Damper % Fan On Lo Spd)	80%	0% to 100%
Damper Position for Exhaust Fan to Turn Off High Speed Fan (Damper % Fan Off Hi Spd)	20%	0% to 100%
Damper Position for Exhaust Fan to Turn On High Speed Fan (Damper % Fan On Hi Spd)	60%	0% to 100%
Demand Ventilation Mode of Operation (Vent Mode)	Disabled	Disabled, Controlled by IAQ, Diff between IAQ and OAQ
Demand Ventilation Indoor Air Quality Setpoint (Vent IAQ Stpt)	1000 ppm	0 ppm to 2000 ppm
Relearn System Relearns the sensors connected to the controller.	False	True, False

Status menu

Table 7: Status menu

Level 2 on MAP Gateway (on LCD)	Description
Unit Status	Displays the overall status of the unit
Economizer Status (Econ Status)	Displays the status of the Economizer damper control
Econ Free Cooling Available (Free Clg Avail)	Displays whether free cooling is available. Possible values: Yes, No.
Economizer Damper % Command (Damper Command)	Displays the damper command percentage. Default value: 15%.

Table 7: Status menu

Level 2 on MAP Gateway (on LCD)	Description
Economizer Damper Position (Damper Feedback)	Displays the percentage reading from the damper feedback sensor.
Supply Air Temperature (Supply Temp)	Displays the reading from the SAT sensor, in the range of -40°F to 150°F.
Outdoor Air Temperature (Outdoor Temp)	Displays the reading from the OAT sensor, in the range of -40°F to 140°F.
Outdoor Humidity	Displays the percentage reading from the OAH sensor in the range of 5% to 100%.
Outdoor Air Enthalpy	Displays the OA enthalpy.
Return Air Temperature (Return Temp)	Displays the reading from the RAT sensor, in the range of 0°F to 140°F.
Return Air Humidity (Return Humidity)	Displays the percentage reading from the RAH sensor, in the range of 5% to 100%.
Return Air Enthalpy	Displays the RA enthalpy.
Occupancy	Displays the reading from the occupancy sensor. Possible values: Occupied, Unoccupied.
Comp Status	Displays the overall compressor status.
Compressor Stage 1 Command (Compressor 1)	Displays the compressor stage 1 command.
Compressor Stage 2 Command (Compressor 2)	Displays the compressor stage 2 command.
Y1-Thermostat (Y1-Tstat)	Displays the thermostat Y1 status.
Y2-Thermostat (Y2-Tstat)	Displays the thermostat Y2 status.
W1-Thermostat (W1-Tstat)	Displays the thermostat W1 status.
Exhaust Fan Status (Exhaust Status)	Displays the exhaust fan status.
ERV Status	Displays the ERV status.
Exhaust Fan Command (Exhaust Fan)	Displays the exhaust fan command. Possible values: Off, On.
Exhaust Fan VFD % Command (Exhaust Command)	Displays the exhaust fan VFD command percentage.
Building Static Pressure (Bldg Pressure)	Displays the reading from the BSP sensor in the range of -0.25 in. W.C. to 0.25 in. W.C.

Advanced Setup menu

Table 8: Advanced Setup menu

Level 2 on MAP Gateway (on LCD)	Default values	Available values
Economizer Enabled for Operation (Econ Enable)	Yes	Yes, No
Supply Temp Stpt	55°F	38°F to 70°F
Damper Min Value	2 VDC	0 VDC to 2 VDC
Feedback Min Value	2 VDC	0 VDC to 2 VDC
Free Cooling Selection (Free Clg Select)	Auto	Dry Bulb, Single Enthalpy, Dual Enthalpy, Auto
Fault Detection Enable (Fault Detect En)	Enable	Enable, Disable
Low Ambient Enabled (Lo Ambient En)	Yes	Yes, No
Low Ambient Economizer Setpoint (Lo Ambient Stpt)	32°F	0°F to 60°F
Low Ambient Economizer Minimum Position (Lo Amb Min Pos)	0%	0% to 80%
OAT Cooling Cutout Enabled (ClgOATCutout-En)	No	Yes, No
OAT Cooling Cutout (ClgOATCutout)	45°F	-45°F to 80°F
Excessive SAT Setpoint (Excess SAT Stpt)	44°F	35°F to 135°F
High Limit Shutoff (High OA Shutoff)	75°F	0°F to 86°F
Demand Ventilation Maximum Economizer Position (Vent Max Pos)	50%	0% to 100%
DCV Econ Dmpr Min Pos Hi Spd Fan (Vent Min Pos Hi)	20%	0% to 100%
DCV Econ Dmpr Min Pos Lo Spd Fan (Vent Min Pos Lo)	50%	0% to 100%
Building Pressure Setpoint (Bldg Press Stpt)	0.1 in. W.C.	-0.25 in. W.C. to 0.25 in. W.C.
Fresh Air Intake Enable (Fresh Air Enable)	Off	On, Off

Table 8: Advanced Setup menu

Level 2 on MAP Gateway (on LCD)	Default values	Available values
Fresh Air Intake Setpoint (Fresh Air Stpt)	800 cfm	0 cfm to 10,000 cfm
Compressor Min Off Time (Cmp Min Off Time)	60 s	60 s to 600 s
Compressor Min On Time (Cmp Min On Time)	60 s	60 s to 600 s
Compressor 1 Lockout (Comp 1 Lockout)	Normal	Normal, Lockout
Compressor 2 Lockout (Comp 2 Lockout)	Normal	Normal, Lockout
Compressor Stage Enabled (Comp Enable)	Yes	Yes, No
Altitude	0 ft	0 ft to 15,000 ft

Advanced Status menu

Table 9: Advanced Status menu

Level 2 on MAP Gateway (on LCD)	Description
Indoor Air Quality (Indoor Quality)	Displays the reading from the indoor air quality sensor in the range of 250 ppm to 2,000 ppm.
Outdoor Quality	Displays the reading from the outdoor air quality sensor.
Fresh Air Intake Value (Fresh Air Flow)	Displays the reading from the outdoor air flow sensor.
Purge	Displays the purge status. Possible values: Normal, Alarm.
Shutdown	Displays the shutdown status. Possible values: On, Off.
OA Damper Control State (Damper State)	Displays the current damper state.
Compressor Control Mode (Comp Ctrl Mode)	Displays the compressor control mode.
Exhaust Control State (Exhaust State)	Displays the exhaust state.
Demand Ventilation Status (Vent Status)	Displays the demand ventilation status.
Comp Avail State	Displays the compressor availability.
Compressor Stage 1 Status (Comp 1 Status)	Displays the status of compressor 1.
Compressor Stage 2 Status (Comp 2 Status)	Displays the status of compressor 2.
Econ Fault State	Displays the economizer fault state.
Excess SAT State	Displays information on the excess SAT state.
Exhaust Control Determination State (Exh Det State)	Displays the exhaust detection state.
Exhaust Control Mode (Exhaust Mode)	Displays the current exhaust mode.
Fresh Air Intake Control Active (Fresh Air Active)	Displays the fresh air active state.
Mechanical Thermostat Sequencer State (Mech Tstat State)	Displays the status of the mechanical thermostat.
OA Damper Control Mode (Damper Mode)	Displays the damper mode.
Staged Output Control State (Staged Out State)	Displays the state of the staged output control.
Startup Delay State (Strt Delay State)	Displays the start-up delay state.

Controller menu

Table 10: Calibration submenu

Level 3 on MAP Gateway (on LCD)	Default values	Available values
SAT Offset	0°F	-5°F to 5°F
OAT Offset	0°F	-5°F to 5°F
OAH Offset	0%	-5% to 5%
RAT Offset	0°F	-5°F to 5°F
RAH Offset	0%	-5% to 5%
BSP Offset	0 in. W.C.	-0.05 in. W.C. to 0.05 in. W.C.
IAQ Offset	0 ppm	-100 ppm to 100 ppm
OAQ Offset	0 ppm	-100 ppm to 100 ppm
FAI Offset	0 cfm	-100 cfm to 100 cfm
Fresh Air Range	10,000 cfm	0 cfm to 50,000 cfm

Table 11: Misc submenu

Level 3 on MAP Gateway (on LCD)	Default values	Available values
Comp 1 Runtime	0 minutes	10,000 minutes
Comp 2 Runtime	0 minutes	10,000 minutes
Reset Accumulator	No	Yes, No
PID Tuning Reset	False	True, False
Damper Integral Time (Damper Int Time)	0	N/A (read-only)
Damper Prop Band	0	N/A (read-only)
Exhaust Integral time (Exh Int Time)	0	N/A (read-only)
Exhaust Prop Band (Exh Prop Band)	0	N/A (read-only)

Table 12: Controller Information submenu

Level 2	Description	Available values
Brightness Setting	You can set the brightness of the display. Default value: 5	3 to 10
Firmware Version	Displays the current firmware version.	N/A
Firmware Status	Displays the firmware status.	Firmware Versions OK Firmware Versions Do Not Match the Package
Language	You can set the language of the device. Default value: English	English, French, Spanish
Units	You can set the units that the device uses. Default value: IP	IP, SI
Relearn System	Relearns the sensors connected to the controller. Default value: False	True, False

Update menu

Table 13: Update menu

Level 2	Description	Available values
View Version	Displays the current firmware version and status.	N/A
Load Firmware	Displays a list of choices that you can load.	N/A
Backup	You can create a backup of the device.	Backup: Wait, Backup 0% Backup: Ok, Backup 100%
Restore	You can restore data from a backup file.	BackupConfig (file name to be restored)
Export Trend	You can export trends.	Exporting, Export Done
SelftestReport	You can create a self-test report.	N/A

Self Test menu

Table 14: Self Test menu

Level 2	Level 3	Level 4	Description
Self Test Status	Current State Status Self Test Status Self Test Time Remaining Self Test Prompt	N/A	Displays information about the test progress or any prompts that you need to answer.

Table 14: Self Test menu

Level 2	Level 3	Level 4	Description
Self Test Start	All Test	N/A	Runs all the tests.
	Equipment Test	Alarm Damper Compressor 1 Compressor 2 Power Exhaust ERV Power Ex VFD	Runs the selected test.
		Acceptance Test	
Self Test Pause	N/A	N/A	Pauses the test.
Self Test Cancel	N/A	N/A	Cancels the test.
Self Test Reset	N/A	N/A	Resets the self test status.

View Results menu

Table 15: View Results menu

Level 2	Available values
Alarm Damper Compressor 1 Compressor 2 Power Exhaust ERV Power Ex VFD OA Ventilation RTU Test Economizer Demand Ctl Vent FDD	Stabilize, Wait, Check, Available, Not Run, Pass, Fail, Warning

Menu conditions

Table 16: Menu conditional variables

Menu item	Condition to appear in the menu
Exhaust Setup	Always appears
Damper Position for Exhaust Fan to Turn On	Exhaust Setup set to Non-Modulating Control and Supply Fan Setup set to Single Speed
Damper Position for Exhaust Fan to Turn Off	Exhaust Setup set to Non-Modulating Control and Supply Fan Setup set to Single Speed
Building Static Pressure Setpoint	Exhaust Setup set to Variable Frequency Fan
OAT Cooling Cutout Enabled	Equipment Type set to Conv RTU
OAT Cooling Cutout	Equipment Type set to Conv RTU and OAT Cooling Cutout Enabled set to True
Supply Fan Type	Equipment Type set to Conv RTU
Low Ambient Economizer Setpoint	Damper Low Ambient set to Enabled

Table 16: Menu conditional variables

Menu item	Condition to appear in the menu
Low Ambient Economizer Minimum Position	Damper Low Ambient set to Enabled
Economizer Damper Minimum Position Low Speed Fan	Supply Fan Type set to Two Speed and DCV set to Disabled
Demand Ventilation Maximum Economizer Position	DCV is not Disabled
Demand Ventilation Indoor Air Quality Setpoint	DCV is not Disabled
Fresh Air Intake Setpoint	Fresh Air Intake is Enabled
DCV Economizer Damper Minimum Position Low Speed Fan	Supply Fan Type set to Two Speed and DCV is not Disabled
DCV Economizer Damper Minimum Position High Speed Fan	Supply Fan Type set to Two-Speed and DCV is not Disabled
Damper Position for Exhaust Fan to Turn Off Low Speed Fan	Exhaust Setup set to Non-Modulating Control and Supply Fan setup is not Single Speed
Damper Position for Exhaust Fan to Turn On Low Speed Fan	Exhaust Setup set to Non-Modulating Control and Supply Fan setup is not Single Speed
Compressor 2 Lockout	The number of compressors > 1
Compressor 2 Test	The number of compressors > 1
Power Exhaust Test	Power Exhaust Test set to Non-Modulating Control
ERV Pivot Test	Exhaust Setup set to ERV
Exhaust VFD Test	Exhaust Setup set to Variable Frequency Fan
OA Vent Test	Fresh Air Intake is Enabled
DCV Test	DCV is not Disabled
SAT Offset	SAT Sensor connected
RAT Offset	RAT Sensor connected
OAT Offset	OAT Sensor connected
OAH Offset	OAH Sensor connected
RAH Offset	RAH Sensor connected
IAQ Offset	IAQ Sensor connected
BSP Offset	BSP Sensor connected
FAI Offset	FAI Sensor connected
OAQ Offset	OAQ Sensor connected
Fresh Air Range	Fresh Air Intake is Enabled
Damper Position For Exhaust Fan to Turn Off High Speed Fan	Exhaust Setup set to Non-Modulating Control and Supply Fan setup is not Single Speed
Damper Position for Exhaust Fan to Turn On High Speed Fan	Exhaust Setup set to Non-Modulating Control and Supply Fan setup is not Single Speed
Exhaust Fan VFD Percent Command	Exhaust Setup set to Variable Frequency Fan
Compressor Stage 2 Command	The number of compressors > 1
Exhaust Fan Command	Exhaust Setup not equal to None
Exhaust Control Determination State	Exhaust Setup not equal to None
Exhaust Control Mode	Exhaust Setup not equal to None
Exhaust Control State	Exhaust Setup not equal to None
Demand Ventilation Status	DCV not equal to Disabled
Fresh Air Intake Control Active	Fresh Air Intake is Enabled
Compressor Stage 2 Status	The number of compressors > 1
Exhaust Fan Status	Exhaust Setup set to Non-Modulating Control or Exhaust Setup set to Variable Frequency Fan
ERV Status	Exhaust Setup set to ERV
Exhaust Prop Band	Exhaust Setup set to Variable Frequency Fan
Exhaust Integral Time	Exhaust Setup set to Variable Frequency Fan
Compressor 2 Test Status	The number of compressors > 1
Power Exhaust Test Status	Exhaust Setup set to Non-Modulating Control
ERV Pivot Test Status	Exhaust Setup set to ERV
Exhaust VFD Test Status	Exhaust Setup set to Variable Frequency Fan
OA Vent Test Status	Fresh Air Intake is Enabled

Table 16: Menu conditional variables

Menu item	Condition to appear in the menu
DCV Test Status	DCV is not Disabled
C2 Runtime	The number of compressors > 1

Self test

About this task:

You can perform a self test to ensure proper operation. The self test verifies configuration, inputs, outputs, and makes it possible for you to run an Acceptance Test for Title 24 compliance. You can select which specific test you would like to run for troubleshooting.

The self test has a stabilization period to drive all the outputs to OFF or 0%. The active period energizes the equipment. The VFD or Supply Fan may run throughout both the stabilization and active periods.

To begin a self test, perform the following steps:

1. Navigate to **Self-Test > Self-Test Start**.
2. Select one of the following options:
 - **All Test:** You can run all the tests.
 - **Equipment Test:** You can run one of the equipment tests, see [Equipment test](#).
 - **Acceptance Test:** You can run one of the acceptance tests, see [Acceptance test](#).

Equipment test

For a list of the possible outputs, see Table 3. For the expected output states of the equipment test, see Table 17.

Damper test

This test changes the damper command to 100%. The test passes if the damper feedback signal reaches 100% within three minutes. If the signal never reaches 100% within three minutes, the test fails. If there is less than 2% of damper feedback after 20 seconds, there is a warning to check the damper position feedback.

Alarm test

This test issues an alarm to a specific output and prompts you to continue. If you continue and then confirm that the alarm is active, the test passes. If you do not respond within 10 minutes to either of the prompt messages, or you do not confirm that the alarm is active, the test fails.

Compressor test

The compressor tests 1 and 2 are available when the occupancy binary input is in the **Occupied** state. The output (Y1 or Y2) activates, and turns on the compressor. If the supply air temperature decreases by 2°F or more within three minutes, the output deactivates, and the test passes. If the supply air temperature does not decrease by at least 2°F within three minutes, the test displays a warning. Other possible results include: Fail - Shut Down Status.

Power exhaust test

This test is only available if the Damper Test Passes. The damper opens and the exhaust fan output activates. The test passes if you confirm within 10 minutes that the exhaust fan is running. If you do

not confirm this within 10 minutes, the test displays a warning. The test fails if the damper does not open.

VFD power exhaust test

This test is only available if the Damper Test passes. The damper opens and the exhaust fan VFD ramps from 0% (off) to 100%. If a building static pressure reading is available, the test monitors the pressure during this ramp-up period. The test passes if the building static pressure decreases.

If the building static pressure sensor is not available, you must confirm that the exhaust fan is running. The test passes if you confirm within 10 minutes that the exhaust fan is running. If you do not confirm this within 10 minutes, the test displays a warning. The test fails if the damper does not open.

ERV pivot test

This test activates the ERV, and prompts you to continue. If you continue and then confirm that the ERV is pivoted, the test passes. If you do not respond within 10 minutes to either of the prompt messages, or you do not confirm that the ERV is pivoted, the test fails.

Output states after the equipment test

The following table shows the expected output states of the self test.

Table 17: Output States During the Self-Test

Test/Output	Y1	Y2	Exhaust Fan	ERV	Damper	Alarm
Alarm	Off	Off	Off	Off	0%	On
Compressor 1	On	Off	Off	Off	0%	Off
Compressor 2	Off	On	Off	Off	0%	Off
Power Exhaust Test	Off	Off	On/Ramp	Off	0%	Off
ERV Pivot Test	Off	Off	Off	On	0%	Off
Damper Test	Off	Off	Off	Off	Ramp Open; Ramp Close	Off

Acceptance test

The Acceptance tests are available when the Damper Test passes. The acceptance test certifies the California Energy Code Title 24 compliance for retrofit units.

Outdoor air ventilation test

The outdoor air ventilation test certifies compliance with NA7.5.1.2 Outdoor Air Acceptance (Form CEC-MECH-2A). This test disables the economizer and DCV, which causes the damper to open to the fixed minimum position. You measure the OA flow and have 10 minutes to respond to the prompt. Possible results include: Fail - OA flow not measured or Pass.

Rooftop unit test

The rooftop unit test evaluates the entire thermostat, economizer, and RTU system and certifies compliance with NA7.5.2 Rooftop Acceptance (Form NRCA-MCH-03-A). This test disables the economizer and DCV operation. You have 20 minutes to perform system tests and respond to a prompt on the controller. Possible results include: Fail - RTU prompt not acknowledged, and Pass.

Economizer test

The economizer test certifies compliance with NA7.5.4 Air Economizer Controls Acceptance (Form NRCA-MCH-05-A). This test disables the DCV and simulates the demand for cooling, free cooling availability, and supply air temperature to quickly open the damper to 100% (Steps 2a and 2b on the form). You must confirm the return air damper operates properly. Another simulation begins to verify integrated economizer operation (Step 2c on the form). The economizer disables and the damper closes to the minimum position (Step 3 on the form). Possible results include: Fail - OA damper not modulating, Fail - RA damper not modulating, Fail - No integrated economizer operation, Fail - Prompt respond not received, and Pass.

DCV test

The DCV test certifies compliance with NA7.5.5 Demand Control Ventilation Systems Acceptance (Form CEC-MECH-6A). The economizer operation disables and an IAQ sensor reading greater than the active setpoint is simulated. The test verifies that the damper opens from the minimum position (Step 1 on the form). After a one-minute delay, an IAQ sensor reading of 0 ppm simulates and the test system verifies that the damper closes to minimum position (Step 2 on the form). Possible results include: Fail - DCV not functioning, and Pass.

FDD test

The FDD test certifies compliance with NA7.5.11 Fault Detection and Diagnostics (FDD) (Form NRCA-MCH-12-A). The system instructs you to disconnect the OA temperature sensor from the unit (Step 2 on the form). You must confirm that a fault is reported. After that, you are instructed to reconnect the OA Temperature sensor (Step 3 on the form) and confirm that the faults are cleared. Possible results include: Fail - Faults not detected, Fail - Faults not cleared, and Pass.