

FEATURES

- CA Title 24 Compliant.
- Direct coupled style actuator standard.
- Stainless steel damper side seals.
- **AMCA certified CD-60 Airfoil dampers blades.**
- **Meets leakage rate as required by ASHRAE 90.1.**
- External linkage system.
- Mechanically secured outside air intake filter.
- Capable of introducing up to 100% outdoor air.
- Metal Filter Included: 23" x 5" x 7/8" (exact)

FEATURES (When Ordered With Control Options)

- Fully modulating damper controls with enthalpy, dry bulb and differential temperature sensor options.
- Selectable economizer changeover temperature set point.
- Requires part number 2ECO402 for Dual Enthalpy.
- CO2 controller standard.

Wall or duct mounted CO2 sensor provided as option:

- CO2WM - Wall Mount
- CO2DM - Duct Mount



Only Ruskin Company Model CD-60 is AMCA Certified

HORIZONTAL DISCHARGE ECONOMIZER WITH AIRFOIL DAMPER BLADES AND BAROMETRIC RELIEF FOR YORK PRESTIGE UNITS:

ZX 04-07; XY, ZY, ZQ, XQ 04-06; XXA7

York Model

ZX 04-06;
XY, ZY, XQ 04
ZQ 04-05

ZX 07;
XY, ZY, XQ 05-06
ZQ 06; XXA7

ProVent P/N

ECOHPRSSDB
(Fully Modulating Dry Bulb)

ECOHPRSSEN
(Fully Modulating Enthalpy)

ECOHPRSTDB
(Fully Modulating Dry Bulb)

ECOHPRSTEN
(Fully Modulating Enthalpy)

Weight

81 Lbs.

** INCLUDES CENTER POST AND FILTER ACCESS PANEL **

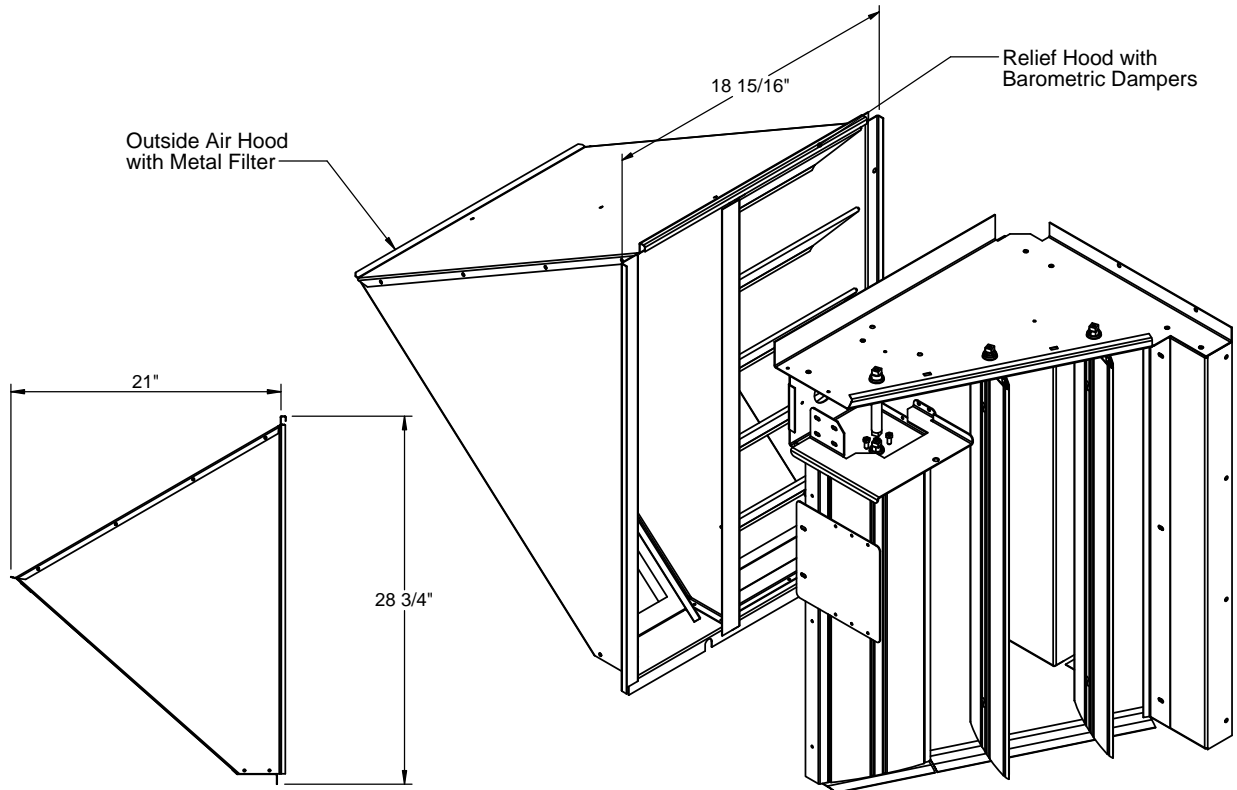

HOOD SIDE DETAIL



3847 WABASH DR.
MIRA LOMA, CA 91725

PHONE (951) 685-1101
FAX (619) 872-9799

SUBMITTED TO: _____
COMPANY: _____
JOB NAME: _____
EQUIPMENT: _____
NOTES: _____

FORM NO:

ECO-89

DATE:

4/25/2018

PART NUMBER:

ECOHPRS Series

REV:

8

DRAWN BY:

CNG