

Installation Instructions

1. The top bracket is configured to accept a 1" filter. To configure for a 2" filter, remove the angle within the bracket. (ILL. 1)
2. Place the bottom bracket into the unit and set within the bottom duct flange. (ILL. 3)
3. Remove the left screw on the front of the heat exchanger plenum and the left screw on the back of the heat exchanger plenum. (ILL. 3)
4. Insert the tab on the top bracket into the notch in the upper tip of the bottom bracket. (ILL. 2) Secure top bracket to the heat exchanger plenum with the screws removed in Step 3. (ILL. 3)
5. Slide filter into place.

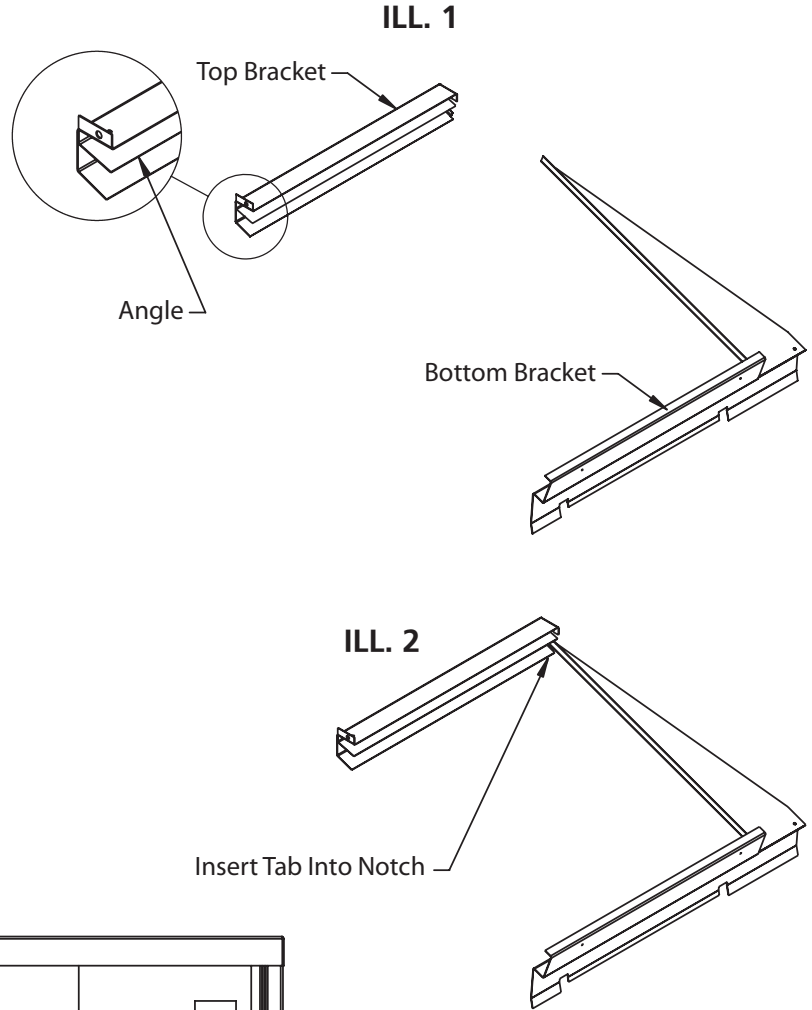

CONTENTS INCLUDED	QTY.
Top Bracket	1
Bottom Bracket	1
19-1/2" x 19-1/2" x 3/4" Filter	1
#10 x 1/2 Sheet Metal Screw	3

