

FEATURES:

- CA Title 24 Compliant.
- Factory assembled.
- Galvanized steel construction.
- **AMCA certified CD-60 Airfoil damper blades.**
- **Meets leakage as required by ASHRAE 90.1**
- Fully insulated.
- Direct coupled actuator.
- Controls package:
 - Includes dry bulb or enthalpy fully modulating controls. w/relay signal switch.
 - Specific control type: Add the two digits below to the Part Number:
 - DB** For dry bulb control.
 - EN** For enthalpy control.

DAMPER MIXING BOXES FOR AVC, AVV, AE SERIES AIR HANDLERS

UNIT SIZE	PART NUMBER	CONTROL TYPE	A"	B"	EST. WT
AVC18-36B AVV25-38B AE, AP18-36B	MB-AVB-AC-**-	ACTUATOR ONLY	15-1/2"	11-1/2"	207 LBS.
	MB-AVB-DB-**-	DRY BULB			
	MB-AVB-EN-**-	ENTHALPY			
AVC36-60C AVV37C-61C AE, AP36-60C	MB-AVC-AC-**-	ACTUATOR ONLY	19"	15"	270 LBS.
	MB-AVC-DB-**-	DRY BULB			
	MB-AVC-EN-**-	ENTHALPY			
AVC48-60D AVV49-61D AE, AP48-60D	MB-AVD-AC-**-	ACTUATOR ONLY	22-1/2"	18-1/2"	333 LBS.
	MB-AVD-DB-**-	DRY BULB			
	MB-AVD-EN-**-	ENTHALPY			

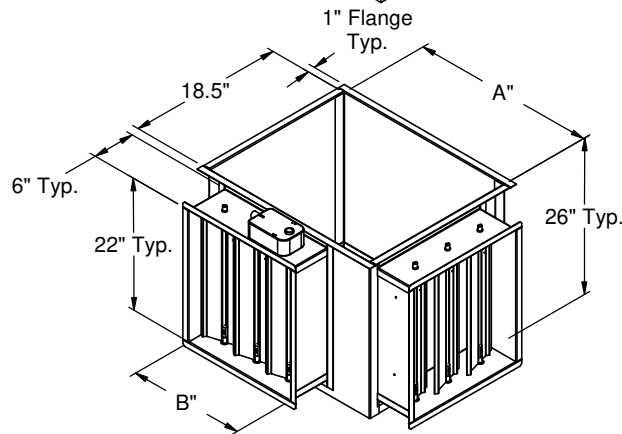
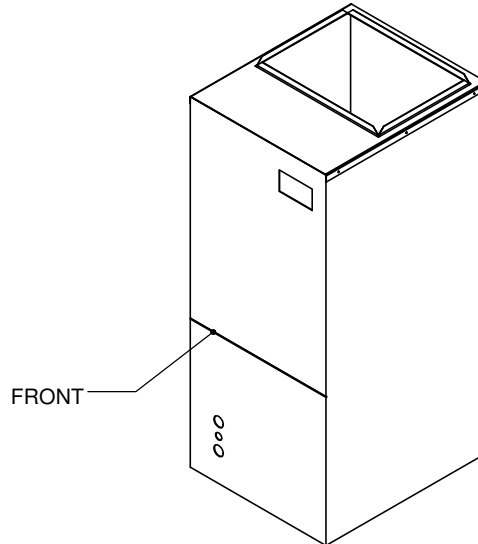

Damper Example Shown
P/N: MB-AV*-**-FA

Damper Locations

A, B, F, D, or E.
First position as Return.
(Added to end of part #)

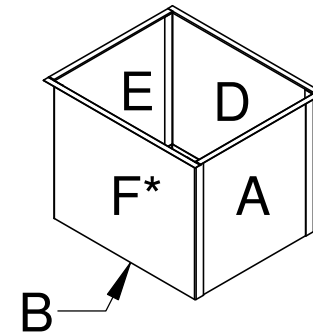

* F Position represents front of Mixing Box which will always match to front of Air Handler.



3847 WABASH DRIVE
MIRA LOMA, CA 91725

PHONE (951) 685-1101
FAX (619) 872-9799

SUBMITTED TO: _____
COMPANY: _____
JOB NAME: _____
EQUIPMENT: _____
NOTES: _____

FORM NO:
-

PART NUMBER:
MB-AV SERIES

DATE:
12/19/2019

REV:
M3

DRAWN BY:
CNG