

FEATURES:

- Painted hood and panel match factory color.
- Designed for unit mounted down discharge and duct mounted horizontal discharge.
- Includes gravity backdraft damper.
- Insulated panel.

0-35% OUTSIDE AIR PACKAGE FOR YORK UNITS

PCG4B, PCE4B 024-042 / PHE4B, PHG4B 024-030

ProVent P/N

WEIGHT

OALXS35

6 Lbs.

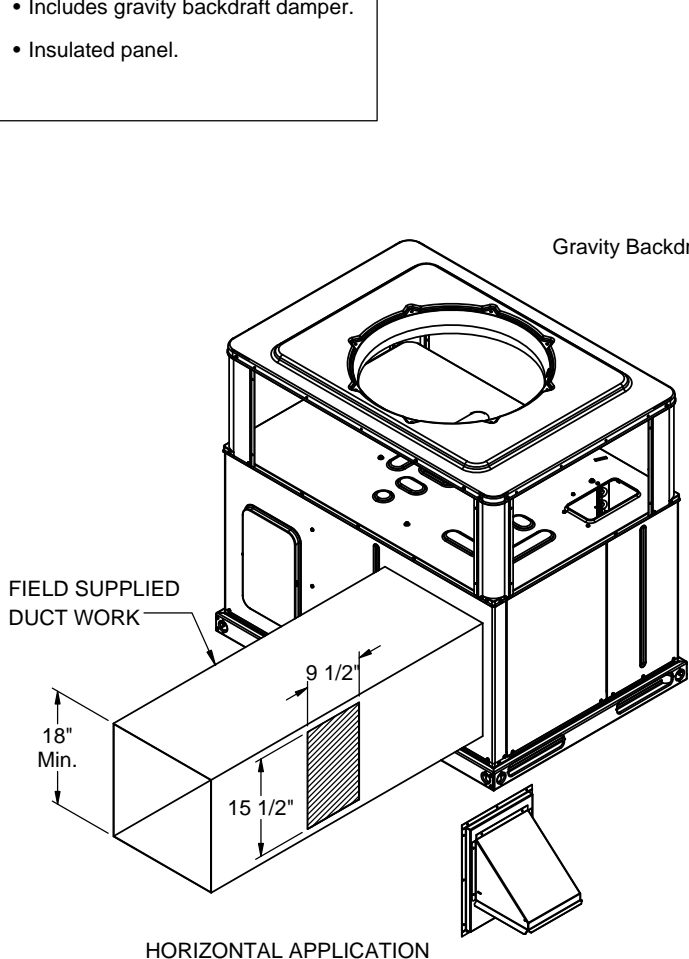

Gravity Backdraft Damper

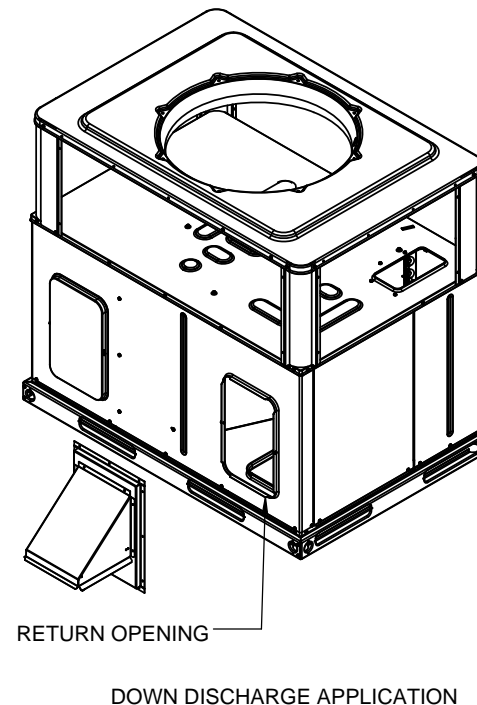
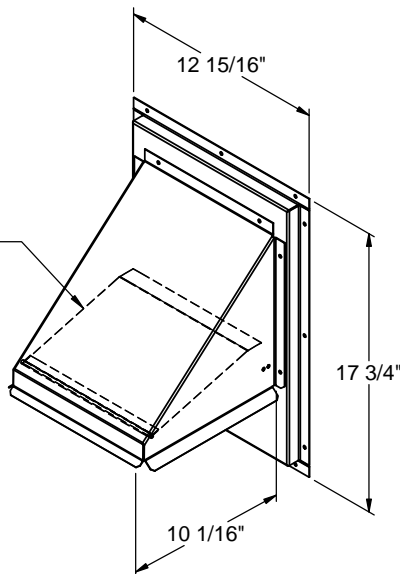

3847 WABASH DRIVE
MIRA LOMA, CA 91752

PHONE (951) 685-1101
FAX (619) 872-9799

SUBMITTED TO: _____
 COMPANY: _____
 JOB NAME: _____
 EQUIPMENT: _____
 NOTES: _____

FORM NO:
OA-35

DATE:
9/11/2015

REV:
-

DRAWN BY:
CNG