

FEATURES

- Roof curb sides and ends are 16 ga galvanized steel.
- Perimeter upper frame supplied with pre-punched assembly holes.
- Assembly hardware provided for field assembly
- Gasketing package provided.
- Heat treated wood nailer provided.

NOTES

- Ductwork must be 3/4" smaller than duct openings shown.
- Adjusts up to 1" in 12" pitch in either direction.
- Attach ductwork to roof curb. Flanges of duct rest on top of curb. Support ductwork below the curb.

KNOCK-DOWN ADJUSTABLE PITCH / ADJUSTABLE HEIGHT CURBS FOR ALLIED UNITS

LGH/LCH 092-120H, 150S; KGA/KCA/KHA 092-150S

ProVent P/N	"A"	"B"	Est. Weight
CBAKDBBX08	8"	12"	92 Lbs.
CBAKDBBX11	11"	15"	110 Lbs.
CBAKDBBX14	14"	18"	133 Lbs.
CBAKDBBX18	18"	22"	158 Lbs.

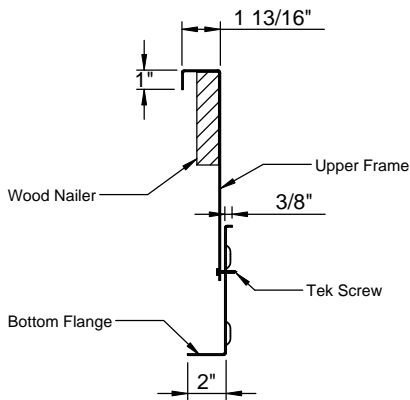
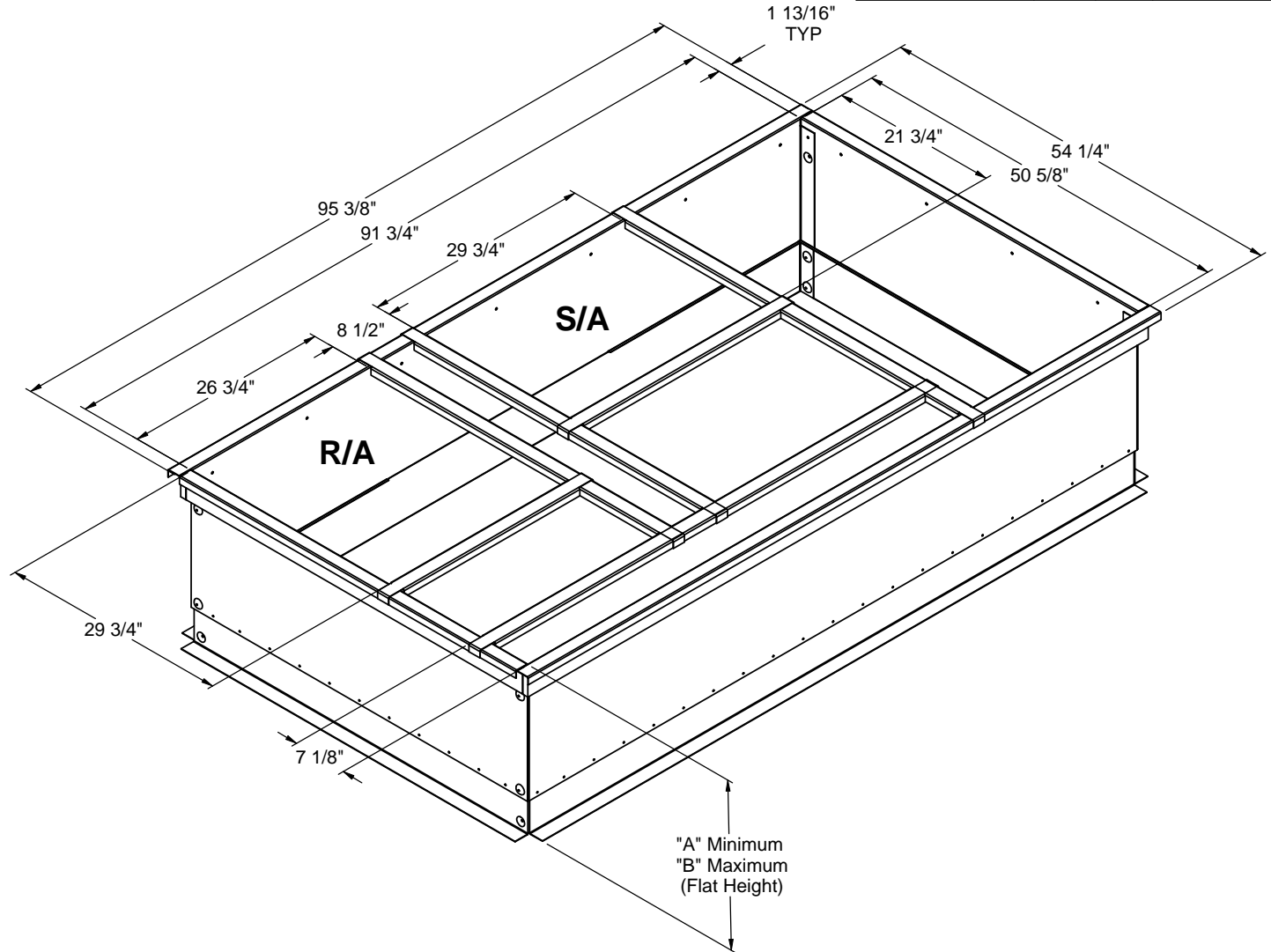

SIDE VIEW DETAIL



**3847 WABASH DRIVE
MIRA LOMA, CA 91752**

**PHONE (951) 685-1101
FAX (619) 872-9799**

SUBMITTED TO: _____
 COMPANY: _____
 JOB NAME: _____
 EQUIPMENT: _____
 NOTES: _____

FORM NO:
CBAKD-200

PART NUMBER:
CBAKDBBX SERIES

DATE:
2/6/2014

REV:
2

DRAWN BY:
CNG