

FEATURES

- Fully welded construction.
- 10 Ga. galvanized support frame.
- Estimated weight - 173 Lbs.
- Gasketing package provided.
- Restraints and springs have OSHPD pre-approval, OPA #0070.

VIBRATION ISOLATION FRAME FOR HORIZONTAL ALLIED UNITS - LOW PROFILE

LGH/LCH 036-072 S/H
KGA/KCA 024-0725, KHA 024-0605

Unit Model	Power Exhaust?	Provent P/N
036-048	NO	CBISHABX1
	YES	CBISHABXP1
060	NO	CBISHABX2
	YES	CBISHABXP2
072	NO	CBISHABX3
	YES	CBISHABXP3

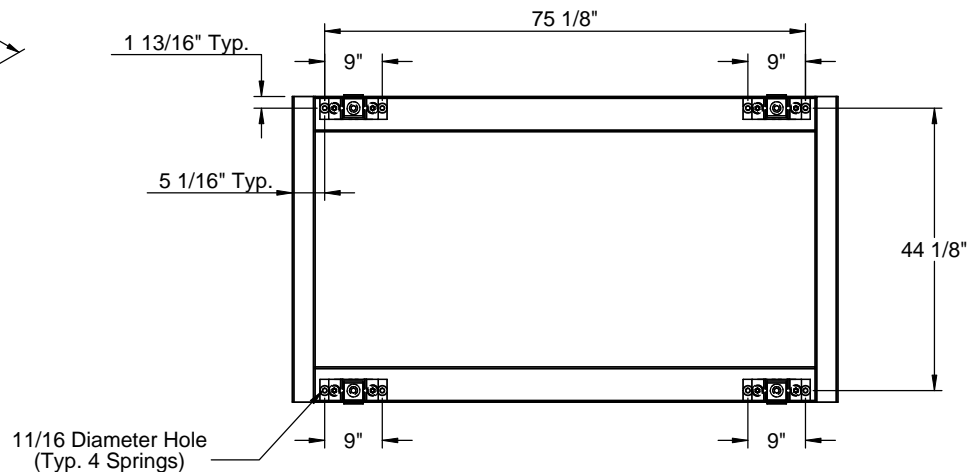
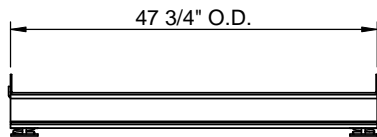
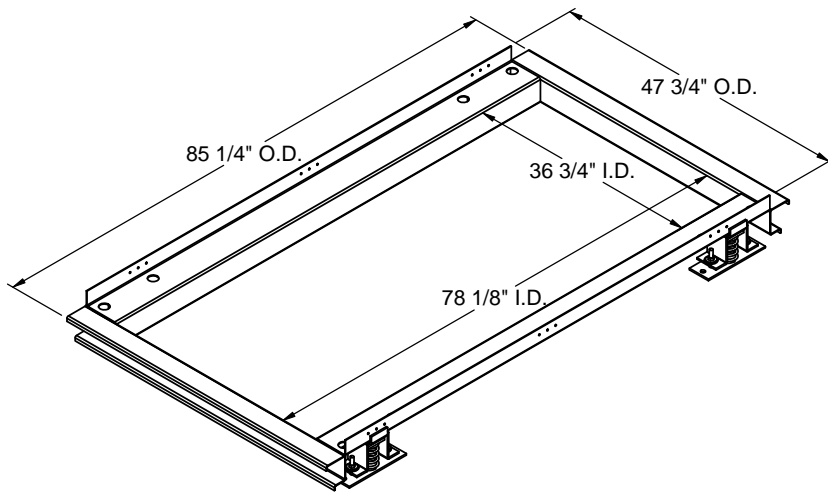

Anchorage Location Detail

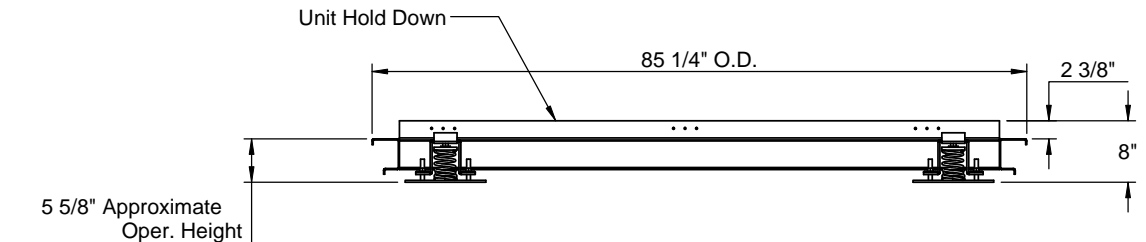

3847 WABASH DR.
MIRA LOMA, CA 91725

PHONE (951) 685-1101
FAX (619) 872-9799

SUBMITTED TO: _____
COMPANY: _____
JOB NAME: _____
EQUIPMENT: _____
NOTES: _____

FORM NO:
CBISH-200

PART NUMBER:
CBISHABX - SERIES

DATE:
4/4/2014

REV:
2

DRAWN BY:
CNG