

FEATURES

- Roof curb perimeter made of 16 ga. galvanized steel.
- Gasketing package provided.
- Heat treated wood nailer provided.
- Corner flanges are pre-threaded for easy bolt on assembly.
- Pitched, adjustable pitch/adjustable height, welded, different height, isolation and calculated curbs are available.

NOTES

- Attach ductwork to roof curb. Flanges of duct rest on top of the curb. Support ductwork below the curb.

KNOCK-DOWN ROOF CURBS FOR ALLIED UNITS

KGA/KCA 090S, KHA 072S

PROVENT P/N	A	EST. WEIGHT
CBKDABK08	8"	65 Lbs.
CBKDABK11	11"	85 Lbs.
CBKDABK14	14"	99 Lbs.
CBKDABK24	24"	146 Lbs.

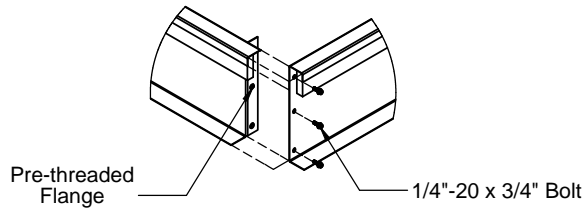
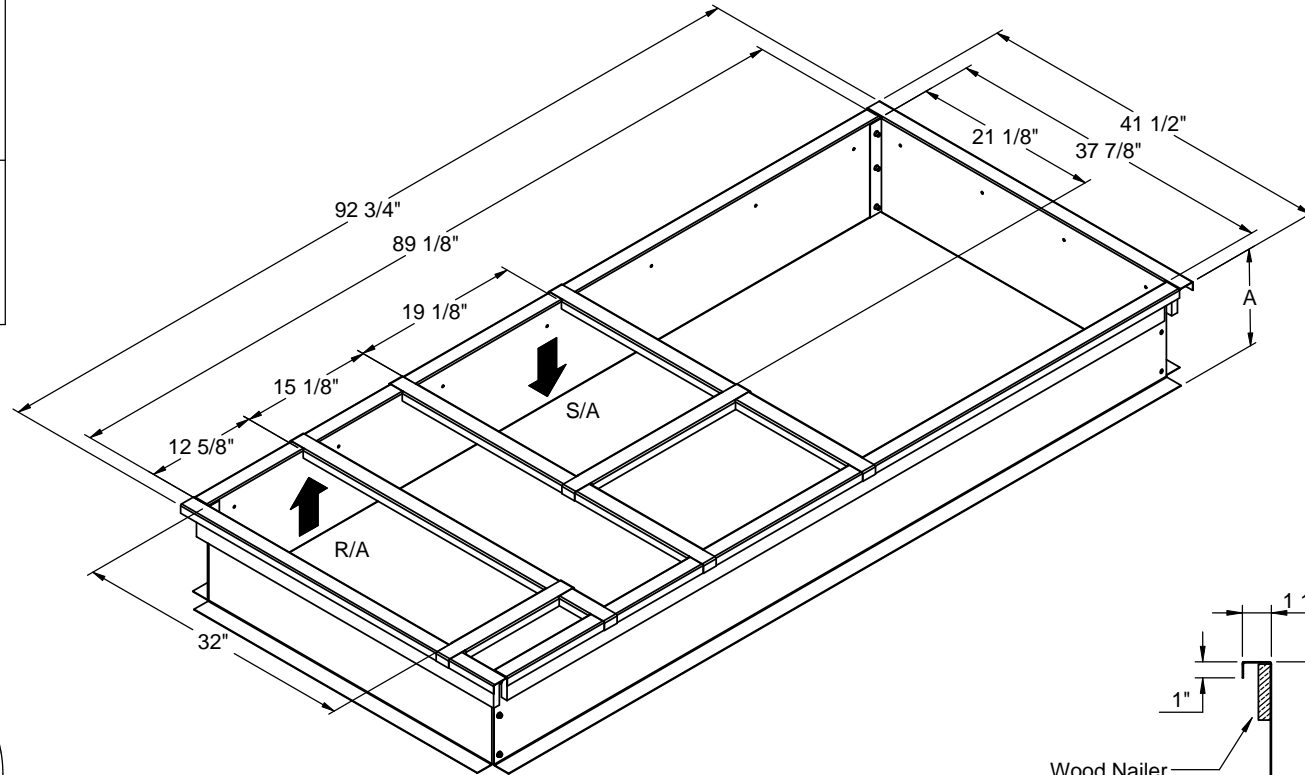

CORNER DETAIL

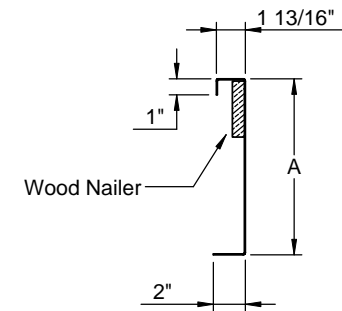

CROSS SECTION DETAIL



3847 WABASH DR.
MIRA LOMA, CA 91725

PHONE (951) 685-1101
FAX (619) 872-9799

SUBMITTED TO: _____
 COMPANY: _____
 JOB NAME: _____
 EQUIPMENT: _____
 NOTES: _____

FORM NO:
CBKD-210

PART NUMBER:
CBKDABK Series

DATE:
1/9/2013

REV:
1

DRAWN BY:
FMM