

FEATURES

- Roof curb perimeter made of 16 ga. galvanized steel.
- Gasketing package provided.
- Heat treated wood nailer provided.
- Corner flanges are pre-threaded for easy bolt on assembly.
- Pitched, adjustable pitch/adjustable height, welded, different height, isolation and calculated curbs are available.

NOTES

- Attach ductwork to roof curb. Flanges of duct rest on top of the curb. Support ductwork below the curb.

KNOCK-DOWN ROOF CURBS FOR ALLIED UNITS

ZGA, ZCA, ZHA 036-060

PROVENT P/N	A	EST. WEIGHT
CBKDABZ08	8"	83 Lbs.
CBKDABZ11	11"	94 Lbs.
CBKDABZ14	14"	105 Lbs
CBKDABZ24	24"	144 Lbs

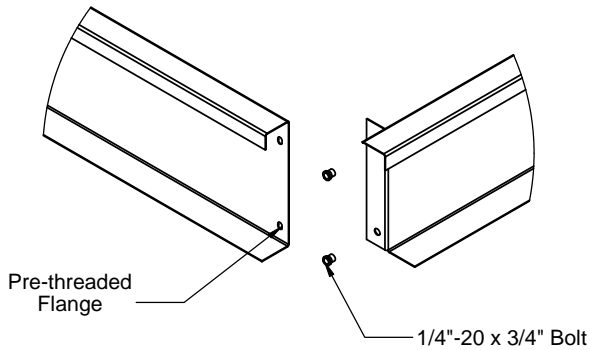
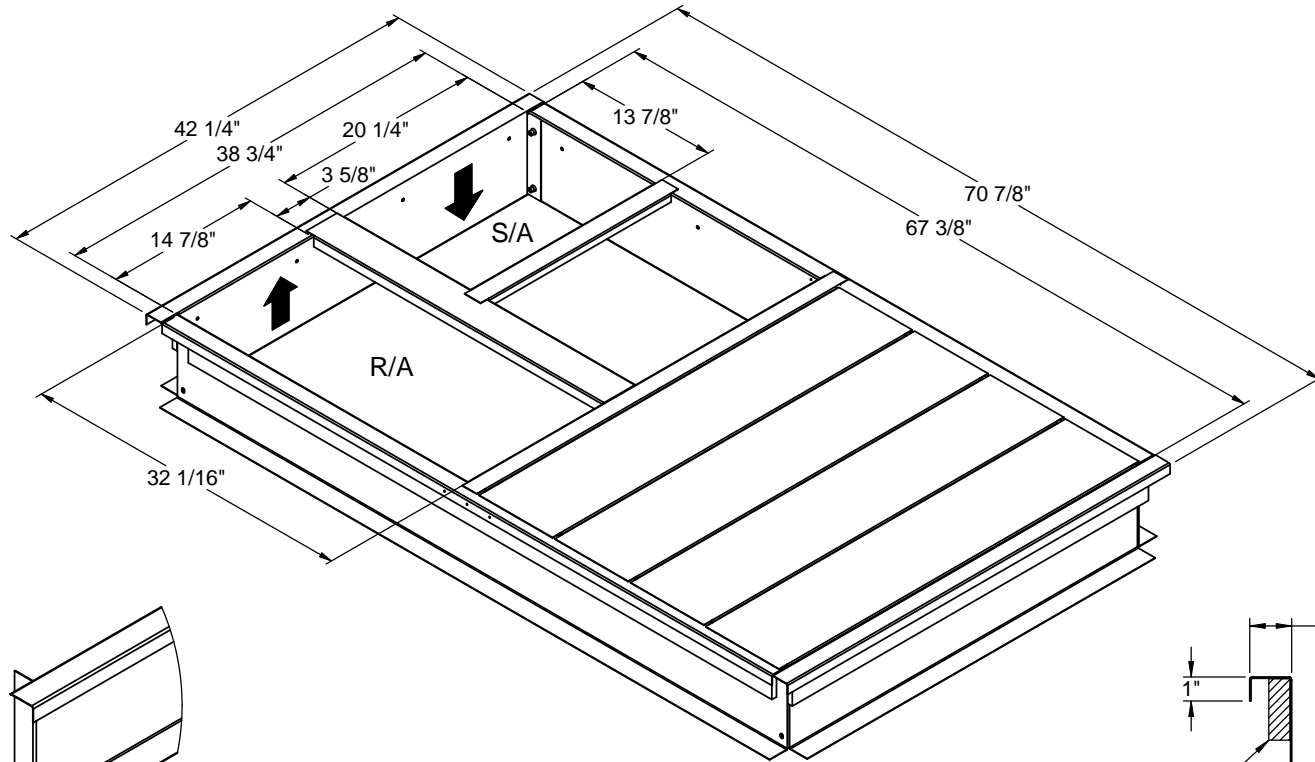

CORNER DETAIL

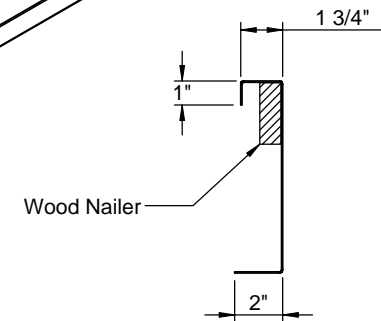

CROSS SECTION DETAIL



3847 WABASH DR.
MIRA LOMA, CA 91725

PHONE (951) 685-1101
FAX (619) 872-9799

SUBMITTED TO: _____
COMPANY: _____
JOB NAME: _____
EQUIPMENT: _____
NOTES: _____

FORM NO:
-

PART NUMBER:
CBKD-211

DATE:
3/22/2013

REV:
-

DRAWN BY:
CNG