

FEATURES:

- Gasketing package provided.
- Insulation: 1"-1.5 lb. Density.
- Estimated Weight: 180 Lbs.
- All Galvanized Welded Construction.

CURB ADAPTER

EXISTING TRANE:
SACB/SFCB C11; BYC 120/130 G

FOR YORK UNITS:
ZH/ZJ 036-061
ZF/ZH/ZJ/ZR/XP/DH/DM/DF/DR/BP 078-150: DJ 150

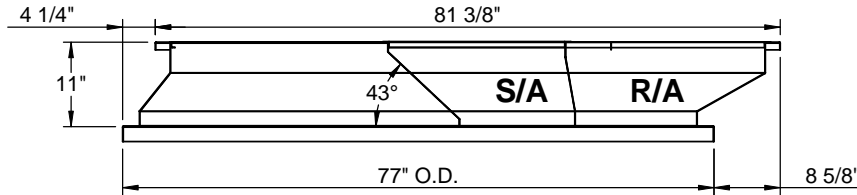

FRONT VIEW

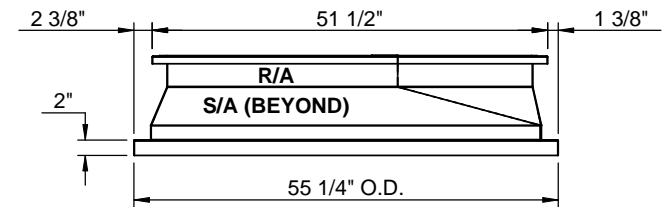

RIGHT VIEW

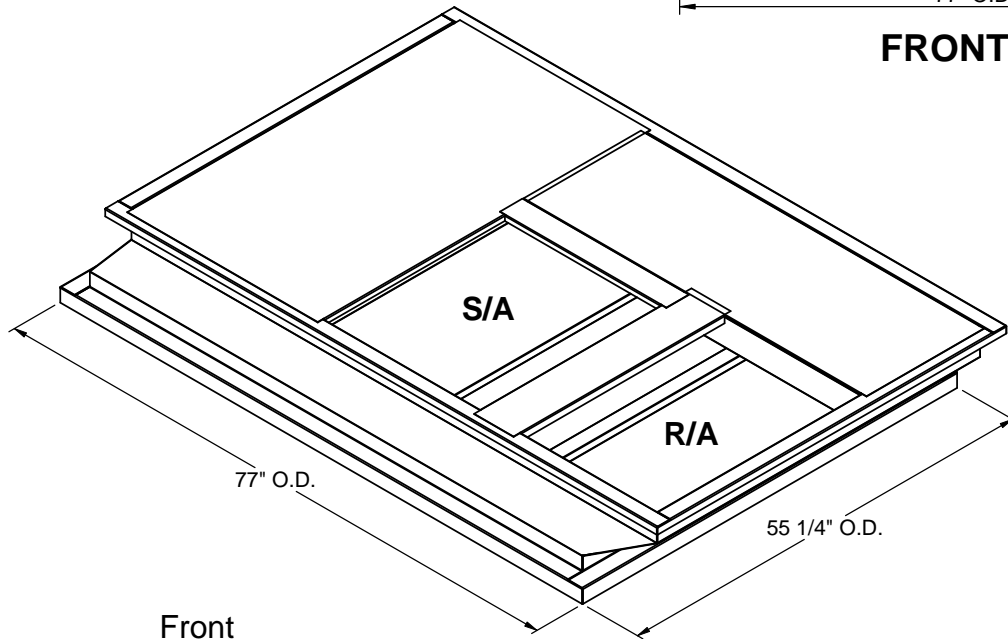

ISOMETRIC VIEW

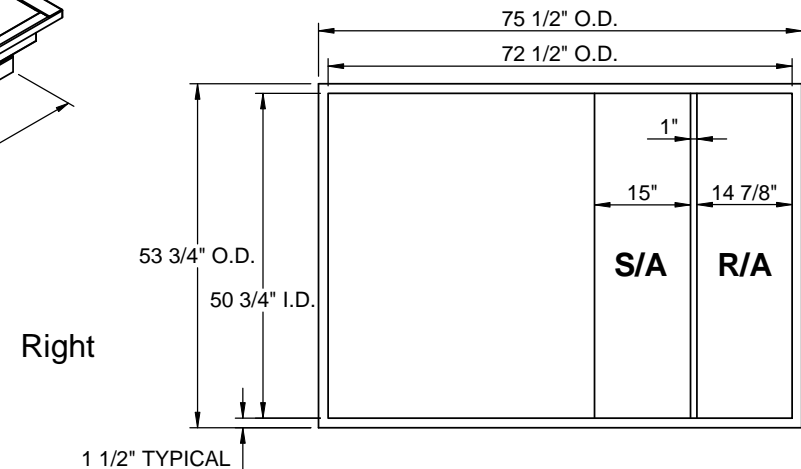

EXISTING CURB



3847 WABASH DRIVE
MIRA LOMA, CA 91752
PHONE (951) 685-1101
FAX (619) 872-9799

SUBMITTED TO: _____
COMPANY: _____
JOB NAME: _____
EQUIPMENT: _____
NOTES: _____

FORM NO: _____
DATE: 3/8/2011

PART NUMBER: CA-PRD3715-TRN16
REV: 0
DRAWN BY: CNG