

FEATURES:

- Gasketing package provided.
- Insulation: 1"-1.5 lb. Density.
- Estimated Weight: 390 Lbs.
- All Galvanized Welded Construction.

CURB ADAPTER

EXISTING TRANE:
BWC 180L

FOR YORK UNITS:
DH/DM/BP/ZF 180

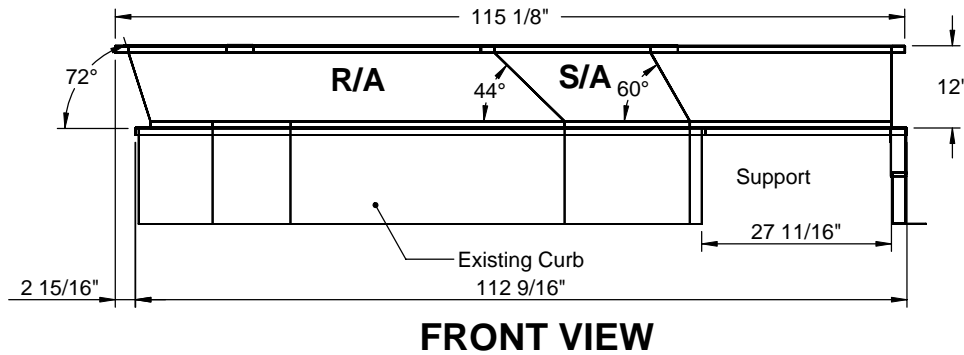

FRONT VIEW

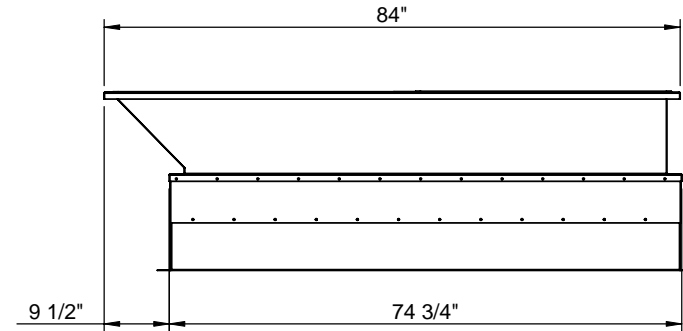

RIGHT VIEW

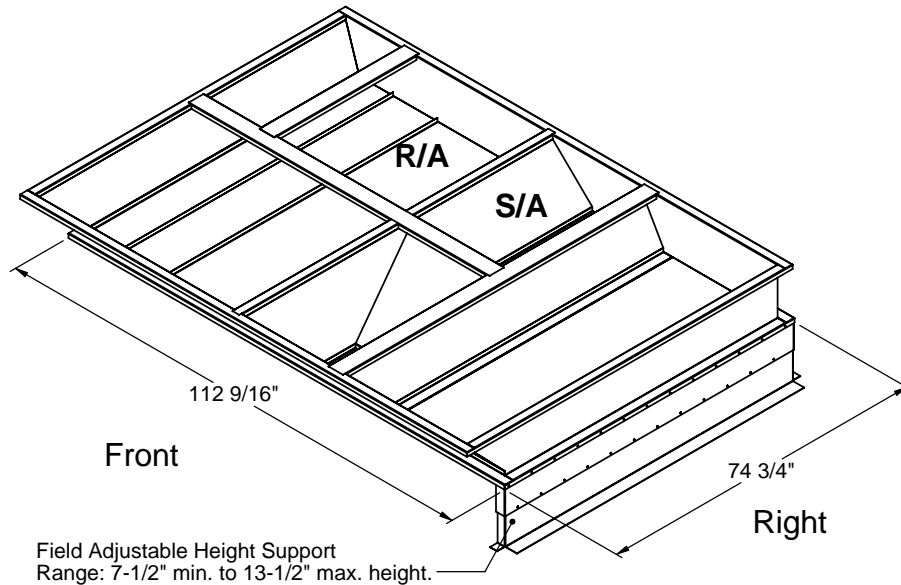

ISOMETRIC VIEW

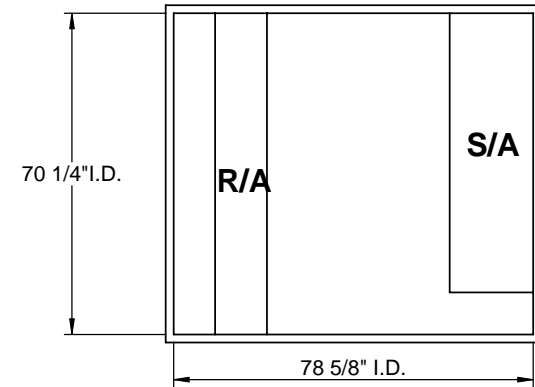

EXISTING CURB



1392 EAST PALOMAR STREET
SUITE 403-234
CHULA VISTA, CA 91913

PHONE (619) 498-9246
FAX (619) 872-9799

SUBMITTED TO: _____
COMPANY: _____
JOB NAME: _____
EQUIPMENT: _____
NOTES: _____

FORM NO: _____

PART NUMBER:
CA-SLU180-TRN01

DATE:
7/10/2009

REV:
1

DRAWN BY:
FMM