

FEATURES

- Roof curb sides and ends are 16 ga. galvanized steel.
- Perimeter upper frame supplied with pre-punch assembly holes.
- Assembly hardware provided for field assembly.
- Gasketing package provided.
- Heat treated wood nailer provided.

NOTES

- Ductwork must be 3/4" smaller than duct openings shown.
- Adjust up to 1" in 12" pitch in either direction.
- Attach ductwork to roof curb. Flanges of duct rest on top of curb. Support ductwork below the curb.

KNOCK-DOWN ADJUSTABLE PITCH / ADJUSTABLE HEIGHT CURBS FOR YORK UNITS

ZE, ZR, XN, XP 036-060, ZF 036-072

ProVent P/N	A	B	WEIGHT
CBAKDSUN367208	8"	12"	78 Lbs
CBAKDSUN367211	11"	15"	90 Lbs
CBAKDSUN367214	14"	18"	102 Lbs

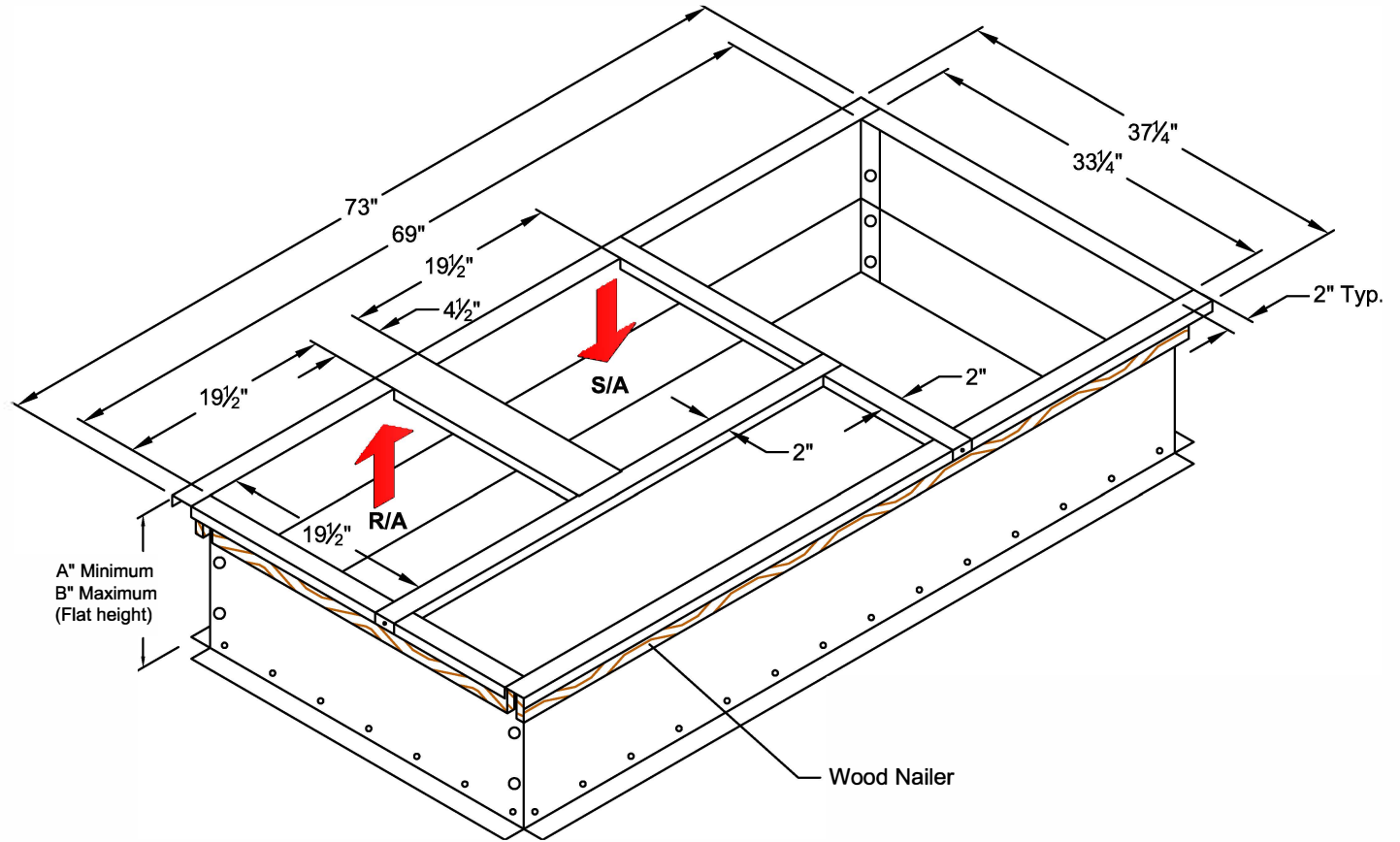

Detail

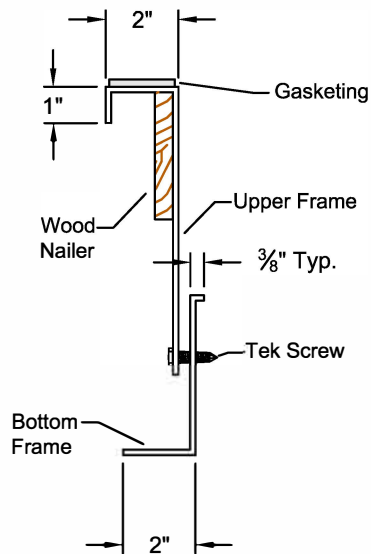

A" Minimum
B" Maximum
(Flat height)



3847 WABASH DR.
MIRA LOMA, CA 91725
PHONE (951) 685-1101
FAX (619) 872-9799

SUBMITTED TO: _____
COMPANY: _____
JOB NAME: _____
EQUIPMENT: _____
NOTES: _____

FORM NO:
CBAKD-102M
DATE: REV:
11/16/17 1

PART NUMBER:
CBAKDSUN3672 SERIES
DRAWN BY:
FMM