

FEATURES:

- Roof curb sides and ends are 16 ga. galvanized steel.
- Fully welded construction.
- Gasketing package provided.
- Heat treated wood nailer provided.
- Insulated deck pan provided.
- Pitched curbs and taller curbs are available.
- CalDyn OSHPD pre-approved 2" deflection seismic restraints. (OPA-0070) JQA.

NOTES

Attach ductwork to roof curb. Flanges of duct rest on top of curb. Support ductwork below the curb.

VIBRATION ISOLATION ROOF CURB FOR YORK UNITS

**ZX08-14; XX08-12; XYA7, ZYA7
ZY07-12; XY07-09; ZL08-14**

PROVENT P/N	A	B	WEIGHT
CBISPRL18**	8"	18"	280 Lbs.
CBISPRL21**	11"	21"	300 Lbs.
CBISPRL24**	14"	24"	320 Lbs.

**Note: Spring configuration must be added to part number at time of order.

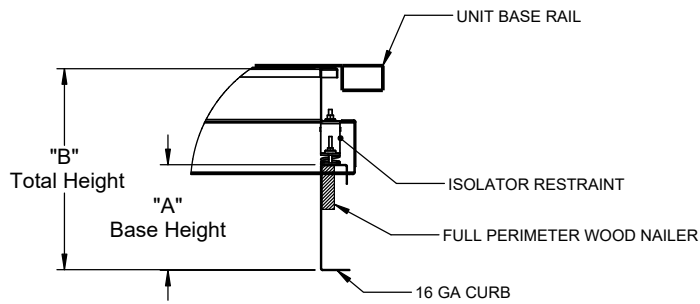
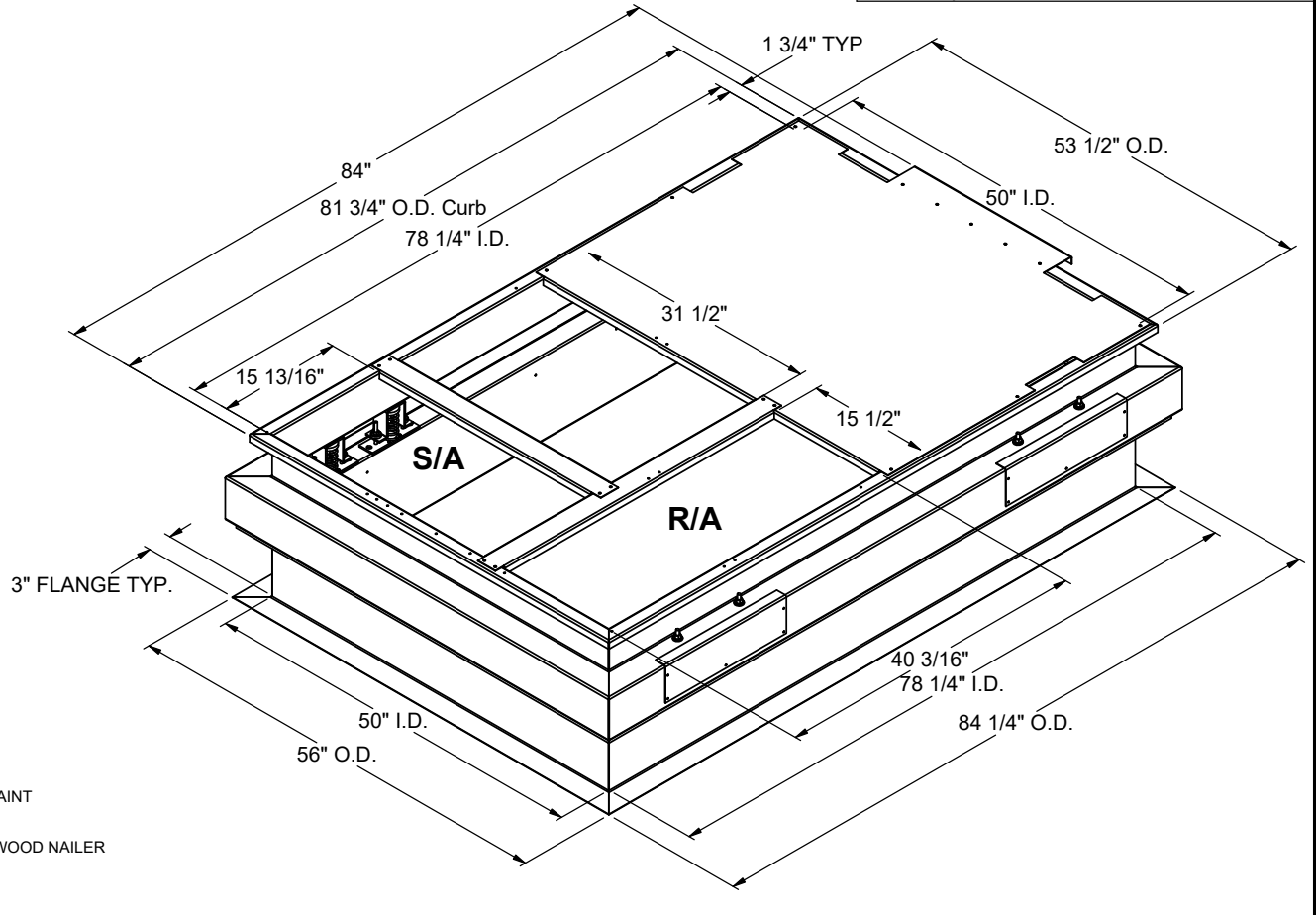

SIDE VIEW DETAIL



3847 WABASH DR.
MIRA LOMA, CA 91752

PHONE (951) 685-1101
FAX (619) 872-9799

JOB NAME: _____
 ADDRESS: _____

 NOTES: _____

FORM NO:
CBIS-118

DATE:
3/17/2022

PART NUMBER:
CBISPRL SERIES

REV:
5

DRAWN BY:
FMM