

**FEATURES**

- Fully modulating damper controls with enthalpy, dry bulb and differential temperature sensor options.
- Selectable dry bulb sensor with changeover temperature of  $\pm 1^\circ$  lag. (No low temperature reset for economizer use.)
- Stainless steel damper side seals.
- **AMCA certified CD-60 Airfoil O/A dampers blades.**
- **Meets leakage rate as required by ASHRAE 90.1.**
- **CD-60 Airfoil R/A damper blades.**
- External linkage system.
- Mechanically secured upgraded outside air intake filter.
- Down or horizontal discharge application.
- "LEED" economizer option.

**CONVERTIBLE ECONOMIZER WITH AIRFOIL DAMPER BLADES AND BAROMETRIC RELIEF FOR ALLIED UNITS**

**LGH/LCH 156-240H; LGH/LCH 300S**

**PROVENT P/N**

**Wt.**

**ECODCBXDB**  
(Fully Modulating Dry Bulb)

127 lb.

**ECODCBXEN**  
(Fully Modulating Enthalpy)

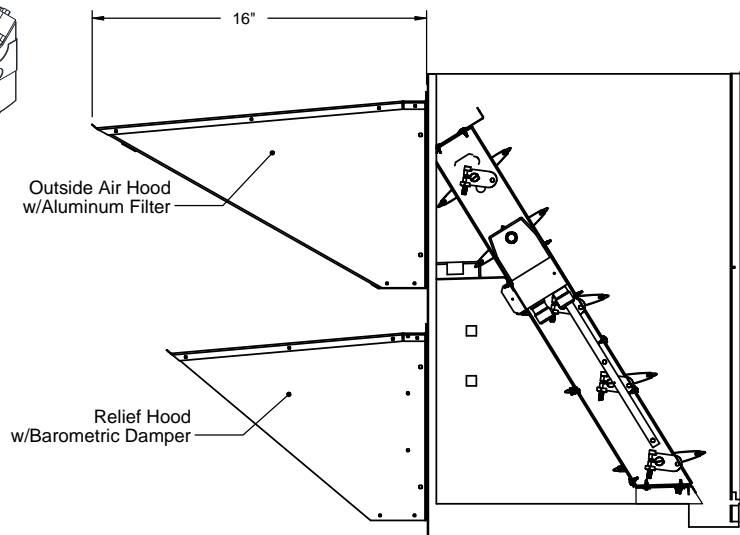
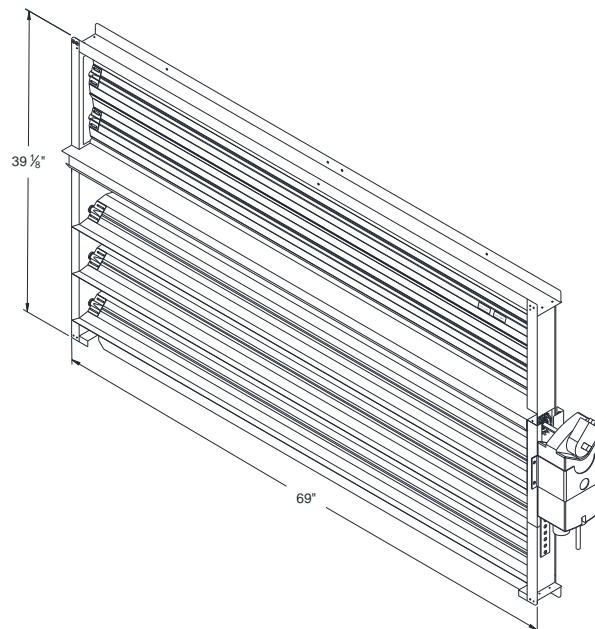

Only Ruskin Company Model CD-60 is AMCA Certified



3847 WABASH DR.  
MIRA LOMA, CA 91725

PHONE (951) 685-1101  
FAX (619) 872-9799

SUBMITTED TO: \_\_\_\_\_  
COMPANY: \_\_\_\_\_  
JOB NAME: \_\_\_\_\_  
EQUIPMENT: \_\_\_\_\_  
NOTES: \_\_\_\_\_

FORM NO:

-

DATE:

1/10/2013

PART NUMBER:

ECODCBX Series

REV:

-

DRAWN BY:

CNG