

FEATURES

- Prepaint hood and panels matching factory specifications and color.
- Designed for unit mounted down or horizontal discharge.
- Includes screen assembly.
- Includes gravity backdraft damper.
- Insulated panel.
- Includes water entrainment filter.

0-25% OUTSIDE AIR PACKAGE FOR YORK UNITS

**DM/DR/DCE/DCG/BP 036-072:
ZJ/XP/DY/DJ/DH/DHE/DHG/BQ/BCH 036-060: DF 072**

ProVent P/N

WEIGHT

OASUN367225FBC

9 Lbs.

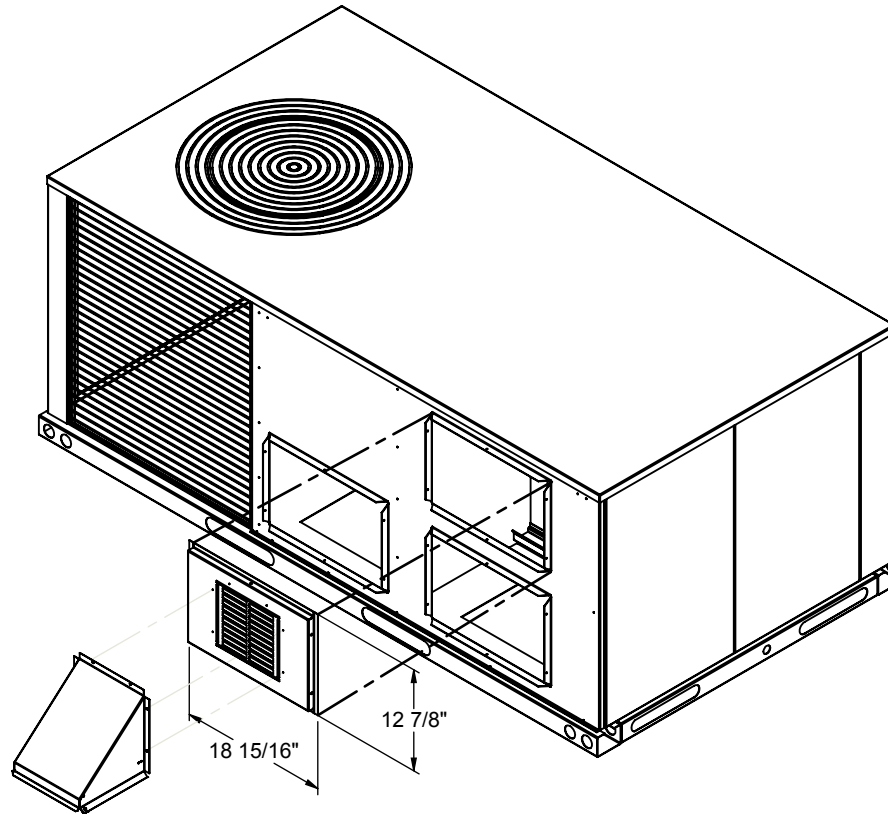

1392 EAST PALOMAR STREET
SUITE 403-234
CHULA VISTA, CA 91913

PHONE (619) 498-9246
FAX (619) 872-9799

SUBMITTED TO: _____
COMPANY: _____
JOB NAME: _____
EQUIPMENT: _____
NOTES: _____

FORM NO:

OA-10

DATE:
8/2/2010

REV:
1

DRAWN BY:
MER