

FEATURES

- Includes fully modulating economizer. (See Form ECO-184 for Economizer Specs).
- CO2 controller standard on economizer. Space or duct mounted CO2 sensor provided as option:
 - CO2WM - Wall Mount With LED
 - CO2DM - Duct Mount
- LEED economizer option.
- Access for motor, blower, and blower drives.
- Adjustable motor sheave.
- Motor with automatic internal thermal protection.
- Modulating option includes fully programmable (factory set) variable frequency drive controlled by a differential pressure transducer designed to continuously monitor space pressure.

DOWN DISCHARGE CENTRIFUGAL POWER EXHAUST ECONOMIZER FOR YORK UNITS

ZH/ZF/ZR 102-150: ZJ/XP 078-150

VOLTAGE	External Static (in. W.G)				FLA	Hp	Wt
	0.1	0.2	0.3	0.4			
230V/3Ph	4,200 cfm	4,000 cfm	3,900 cfm	3,800 cfm	5.6	2	220 Lbs. (Includes Economizer)
460V/3Ph					2.8		

PLEASE NOTE:

1. Return air duct, dampers, return air grills are specific for each unit.
2. For proper electrical wire sizing, Provent power exhaust full load amps need to be added to equation.

ProVent P/N

CONSTANT VOLUME	MODULATING
PEDCPRDLCDB25CS 208/230V 3Ph Selectable Dry Bulb	PEDCPRDLCDB25MS 208/230V 3Ph Selectable Dry Bulb
PEDCPRDLCEN25CS 208/230V 3Ph Enthalpy	PEDCPRDLCEN25MS 208/230V 3Ph Enthalpy
PEDCPRDLCDB46CS 460V 3Ph Selectable Dry Bulb	PEDCPRDLCDB46MS 460V 3Ph Selectable Dry Bulb
PEDCPRDLCEN46CS 460V 3Ph Enthalpy	PEDCPRDLCEN46MS 460V 3Ph Enthalpy

Note: For factory installed LEED economizer / power exhaust option, part number, FLOWECPRD3715, must be added.

LEED ECONOMIZER / POWER EXHAUST OPTION

- ProVent P/N: FLOWECPRD3715
- Outside air measurement for dilution utilizing thermal dispersion technology and ASHRAE 62.1 compliant. Provides LEED credit by supplying feedback on ventilation system performance ensuring that the ventilation system maintains design requirements.
- Factory installed onto economizer/power exhaust standard.
- Provides analog outputs for BMS, visual or audible alert, and generates an alarm when conditions vary by 10% or more of set point.

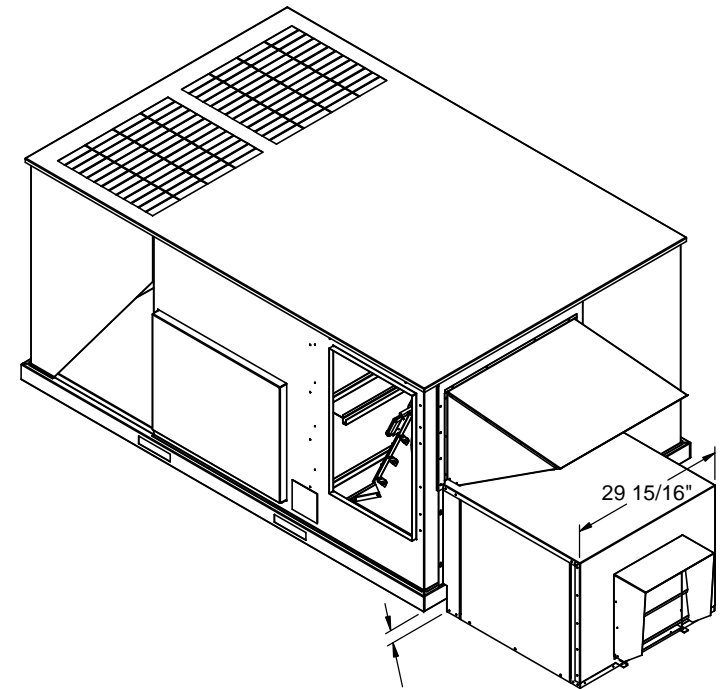
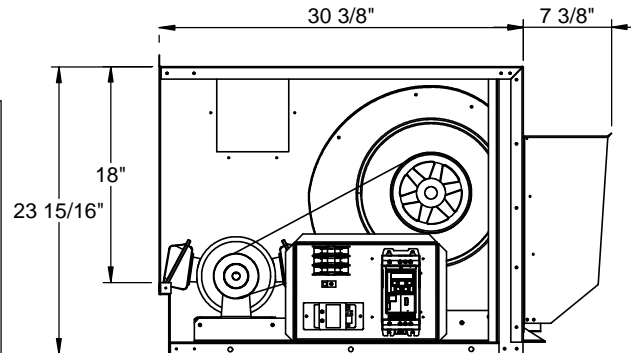
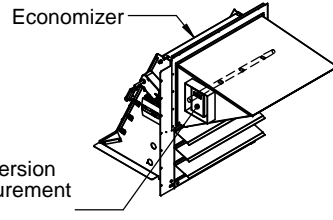

Only Ruskin Company Model CD-60 is AMCA Certified



3847 WABASH DR.
MIRA LOMA, CA 91725

PHONE (951) 685-1101
FAX (619) 872-9799

SUBMITTED TO: _____
 COMPANY: _____
 JOB NAME: _____
 EQUIPMENT: _____
 NOTES: _____

FORM NO:
PE-88

PART NUMBER:
PEDCPRDLCS SERIES

DATE:
8/12/2016

REV:
1

DRAWN BY:
JG