

**FEATURES**

- Fully modulating damper controls with enthalpy, dry bulb and differential temperature sensor options.
  - Selectable dry bulb sensor with changeover temperature of  $\pm 1^\circ$  lag. (No low temperature reset for economizer use.)
  - Direct couple actuator standard.
  - Stainless steel damper side seals.
  - **AMCA certified CD-60 Airfoil O/A dampers blades.**
  - **Meets leakage rate as required by ASHRAE 90.1.**
  - **CD-60 Airfoil R/A damper blades.**
  - Mechanically secured upgraded outside air intake filter.
  - Down discharge application.
  - CO2 controller standard.
- Space or duct mounted CO2 sensor provided as option:
- CO2SM - Space Mount
  - CO2DM - Duct Mount
- Capable of introducing up to 100% outdoor air.

**DOWN DISCHARGE ECONOMIZER WITH AIRFOIL DAMPER BLADES AND BAROMETRIC RELIEF FOR ALLIED UNITS**

**ZGA, ZCA, ZHA 036-060**

**PROVENT P/N**

**Wt.**

**ECODABZSDB (036-060)**  
(Fully Modulating Dry Bulb)

84 Lb.

**ECODABZSEN (036-060)**  
(Fully Modulating Enthalpy)

**ECODABZLDB (ZHA 060)**  
(Fully Modulating Dry Bulb)

84 Lb.

**ECODABZLEN (ZHA 060)**  
(Fully Modulating Enthalpy)

Economizer CD 60 Airfoil Damper Assembly O/A & R/A

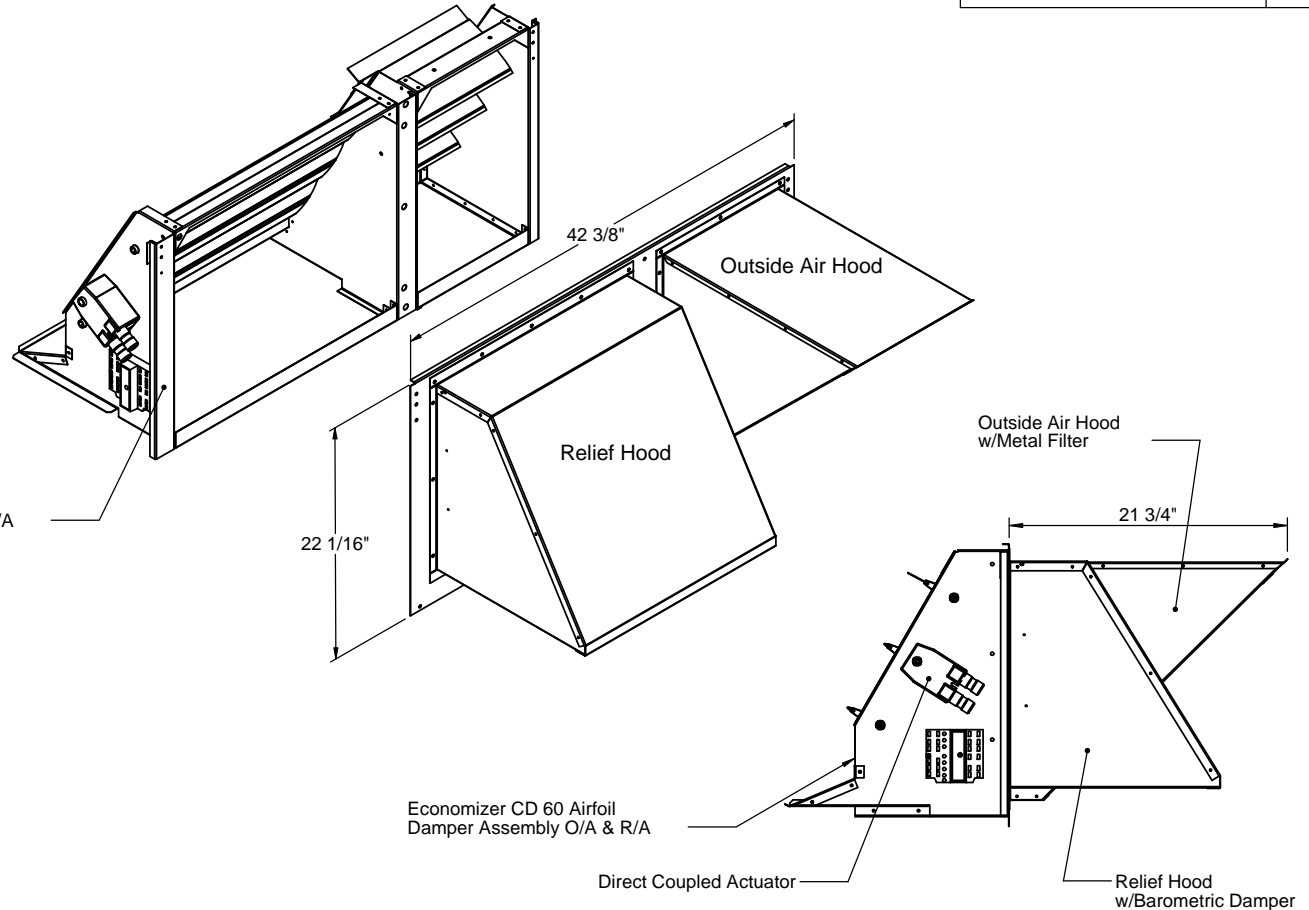

Only Ruskin Company Model CD-60 is AMCA Certified



3847 WABASH DR.  
MIRA LOMA, CA 91725

PHONE (951) 685-1101  
FAX (619) 872-9799

SUBMITTED TO: \_\_\_\_\_  
COMPANY: \_\_\_\_\_  
JOB NAME: \_\_\_\_\_  
EQUIPMENT: \_\_\_\_\_  
NOTES: \_\_\_\_\_

FORM NO:

-

DATE:

7/29/2013

PART NUMBER:

ECODABZ Series

REV:

1

DRAWN BY:

CNG