

**FEATURES**

- Modulating option includes fully programmable (factory set) variable frequency drive controlled by a differential pressure transducer designed to continuously monitor space pressure.
- CO2 controller standard on economizer. Space or duct mounted CO2 sensor provided as option:
  - CO2WM - Wall Mount With LED
  - CO2DM - Duct Mount
- Access door for motor, blower, and blower drives.
- Adjustable motor sheave.
- Motor with automatic internal thermal protection.

**DOWN OR HORIZONTAL DISCHARGE CENTRIFUGAL POWER EXHAUST MODULE FOR ALLIED UNITS**

KGA/KCA 024-072S  
KHA 024-060S

VOLTAGE	External Static (in. W.G)				FLA	Hp	Wt
	0.1	0.2	0.3	0.4			
230V/3Ph	4,200 cfm	4,000 cfm	3,900 cfm	3,800 cfm	5.6	2	220 Lbs.
460V/3Ph					2.8		

**ProVent P/N**

CONSTANT VOLUME	MODULATING
<b>PECCABKSDB25C</b> 208/ 230V 3Ph Selectable Dry Bulb	<b>PECCABKSDB25M</b> 208/ 230V 3Ph Selectable Dry Bulb
<b>PECCABKSEN25C</b> 208/ 230V 3Ph Enthalphy	<b>PECCABKSEN25M</b> 208/ 230V 3Ph Enthalphy
<b>PECCABKSDB46C</b> 460V 3Ph Selectable Dry Bulb	<b>PECCABKSDB46M</b> 460V 3Ph Selectable Dry Bulb
<b>PECCABKSEN46C</b> 460V 3Ph Enthalphy	<b>PECCABKSEN46M</b> 460V 3Ph Enthalphy
<b>PECCABKSDB06C</b> 208/ 230V 1Ph Selectable Dry Bulb	<b>PECCABKSDB06M</b> 208/ 230V 1Ph Selectable Dry Bulb
<b>PECCABKSEN06C</b> 208/ 230V 1Ph Enthalphy	<b>PECCABKSEN06M</b> 208/ 230V 1Ph Enthalphy

**PLEASE NOTE:**

1. Return air duct, dampers, return air grills are specific for each unit.
2. For proper electrical wire sizing, Provent power exhaust full load amps need to be added to equation.

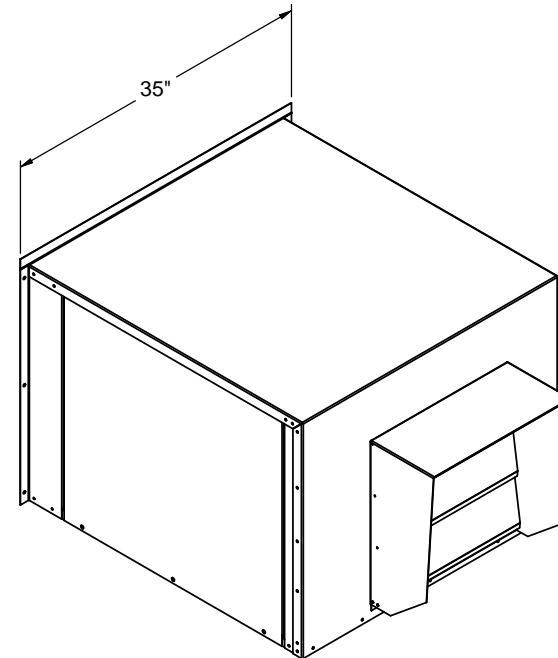
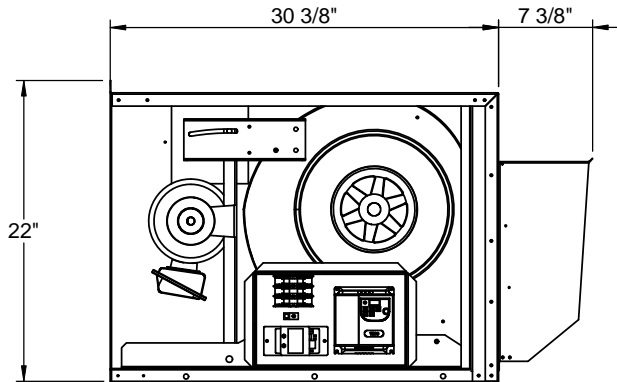

3847 WABASH DR.  
MIRA LOMA, CA 91725

PHONE (951) 685-1101  
FAX (619) 872-9799

SUBMITTED TO: \_\_\_\_\_  
 COMPANY: \_\_\_\_\_  
 JOB NAME: \_\_\_\_\_  
 EQUIPMENT: \_\_\_\_\_  
 NOTES: \_\_\_\_\_

FORM NO:  
PE-304

DATE:  
7/8/2014

PART NUMBER:  
PECCABK SERIES

REV:  
1

DRAWN BY:  
JG