

Application

Ruskin Rooftop Systems 530 series concentric diffuser systems are designed to provide a single point air distribution system with the added benefit of having directional air control. The systems may be used with either a "T-Bar" ceiling, a plaster ceiling, or with no ceiling at all.

Features

- Even 4-way air distribution
- All anodized aluminum diffuser frame
- Aluminum return air egg crate
- Double deflection diffuser
- Built-in Anti-Sweat gasket
- Molded fiberglass transition
- Built-in hanging supports
- Fiberglass duct-board diffuser box
- Stainless steel thumb screws
- Fully insulated (both supply and return)

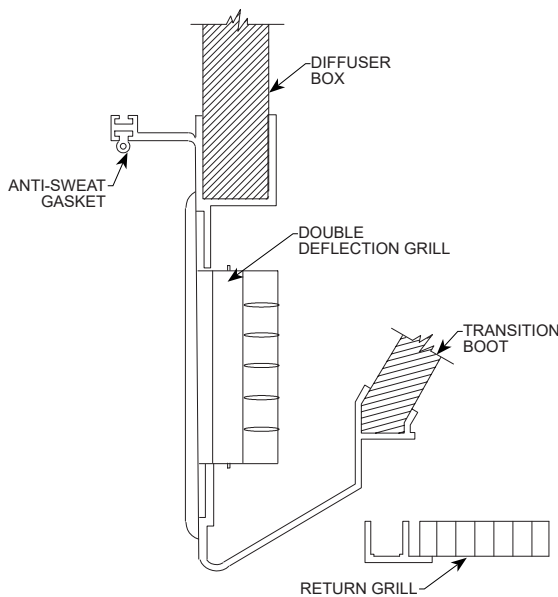
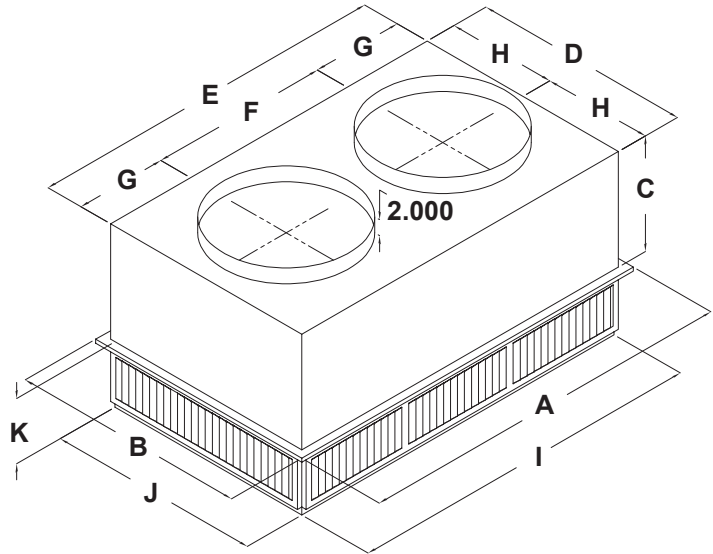

Recommended Specification

Diffusers shall consist of an aluminum supply diffuser with an aluminum egg-crate return. Unit shall be complete with a permanent non-adhesive anti-sweat gasket and hanging supports. Diffusers five ton and smaller shall have a molded fiberglass interior transition. Units fifteen ton and larger shall have supply duct through return transition ensure equal airflow to all four sides of diffuser. Manufacturers published data sheet shall include CFM rating, velocity rating, noise, static, and throw information. Side Discharge mount concentric diffusers shall be in all respects equivalent to Ruskin Rooftop Systems Model 530 Series.

DIMENSIONAL DATA

RRS MODEL#	A	B	C	D	E	F	G	H	I	J	K	DUCT SIZE
01-530-16B	47.625	23.625	11.375	21.500	45.500	22.500	11.500	10.750	45.500	21.500	7.125	16 ROUND

ENGINEERING DATA

RRS MODEL#	CFM	STATIC PRESSURE	THROW FEET	NECK/JET VEL.	NOISE LEVEL	WEIGHT	GRILL COLOR	FILTER	BOX TYPE
01-530-16B	600	.09	8-15	210	20 db	38 lbs	ALUMINUM - GRAY	NOT INCLUDED	FIBERGLASS
	800	.11	9-16	281					
	1000	.14	10-17	351					
	1200	.17	11-18	421					

JANUARY 7, 2022 FORM# RRS_53016

SUPERSEDES: 07-07-17