



INSTALLATION INSTRUCTIONS

ECOHLX_1 Series Horizontal Economizer and PEHALX Series Economizer with Power Exhaust for York LX Series

PLEASE NOTE: This instruction provides the necessary information to properly field- install the economizer assembly on 2 ton through 5 ton single package rooftop units.

The damper accessory provides the return air and outdoor air dampers and actuator for the economizer operations. Contained in this kit are all rain hood components.

PLEASE NOTE: If the unit is 208/230V, single phase, power supply, the installed 40VA transformer needs/must be replaced with a 75VA transformer. All other factory units have the 75VA transformer installed standard.

Before Starting Installation

Warning

Shut power to unit prior to any work being done. Personal injury or death could result.

Only qualified HVAC service personnel should install, troubleshoot, repair or service HVAC and related HVAC equipment.

PARTS INCLUDED	QTY.
#10 x 1/2 Sheet Metal Screw	12
Terminal Block with Wire Harness	1
Tie Wraps	5
Gasket 1/8" x 1/2"	6 ft.
Gasket 3/4"x 1-1/4"	7 ft.
Discharge Air Sensor	1

General

This instruction provides the necessary information to properly field- install a horizontal economizer assembly on 2 ton through 5 ton single package rooftop units.

Horizontal Economizers are used with units for automatic sensor- controlled introduction of outdoor air into the system through an electro-mechanically controlled damper.

1. Disconnect the power Supply.
2. Remove electrical/filter access panel from RTU. (ILL. 2)

Please Note: If filter rack is to be installed, please do so at this time.

3. Before installing economizer into the unit, make sure the duct cover has been removed. Place the economizer into the unit and make sure the return damper of the economizer lines up with the return opening. (ILL. 3)
4. Install the outside air hood and secure the hood and economizer with the metal screws provided. (ILL. 4)

ILL. 1

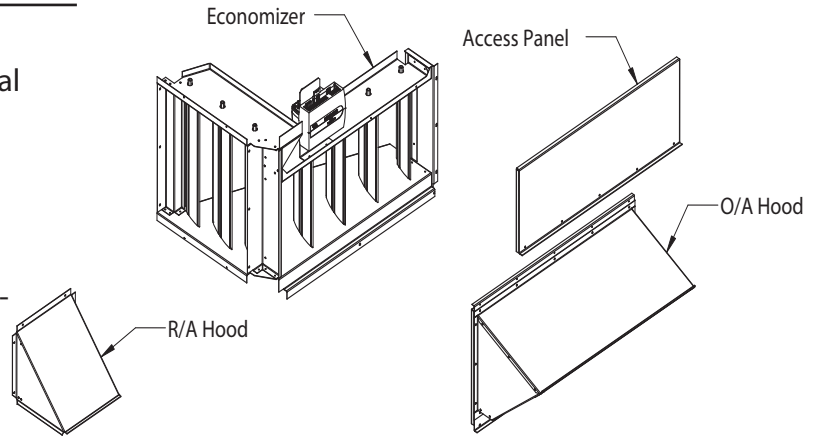

ILL. 2

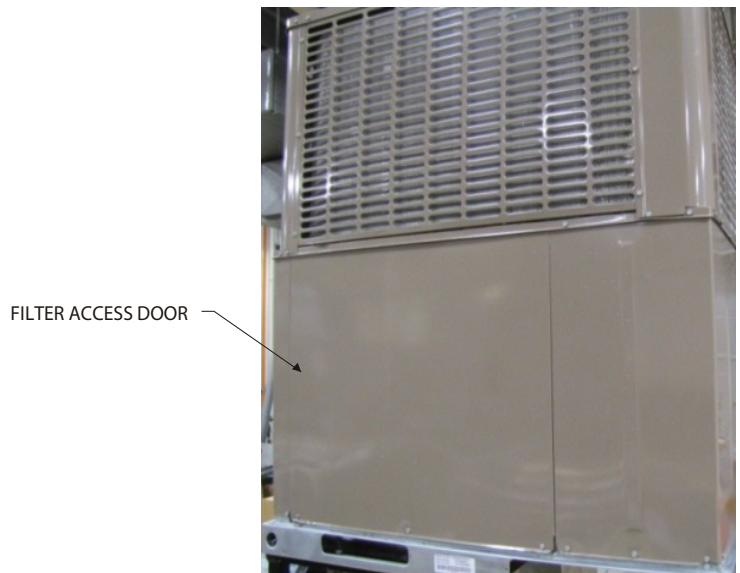

5. Drill 1/2" hole in compressor barrier as needed to route wiring to main control board and sensors. Tightly seal opening around wires.
6. Route wire through existing openings to control panel. Wire according to wiring diagram. (ILL. 8 thru ILL. 11)
7. The discharge air sensor should be mounted on the blower wheel wrap. Use only #8 screws shorter than 1/2" in length to avoid hitting the blower wheel.
8. Use the top access panel provided to close the gap between the top of the economizer and the unit. (ILL. 5)
9. Install duct on return air duct connection.
10. If the barometric relief is to be installed cut a 9" wide x 8" tall hole in the return air duct near the economizer. (ILL. 6)
11. Secure pressure relief damper near economizer over hole in return air duct using (4) screws. (ILL. 7)
12. Place the adhesive backed wiring diagram on the low voltage compartment access panel by the unit diagram. Reinstall low voltage compartment access panel.
13. Turn power on to RTU.

ILL. 3

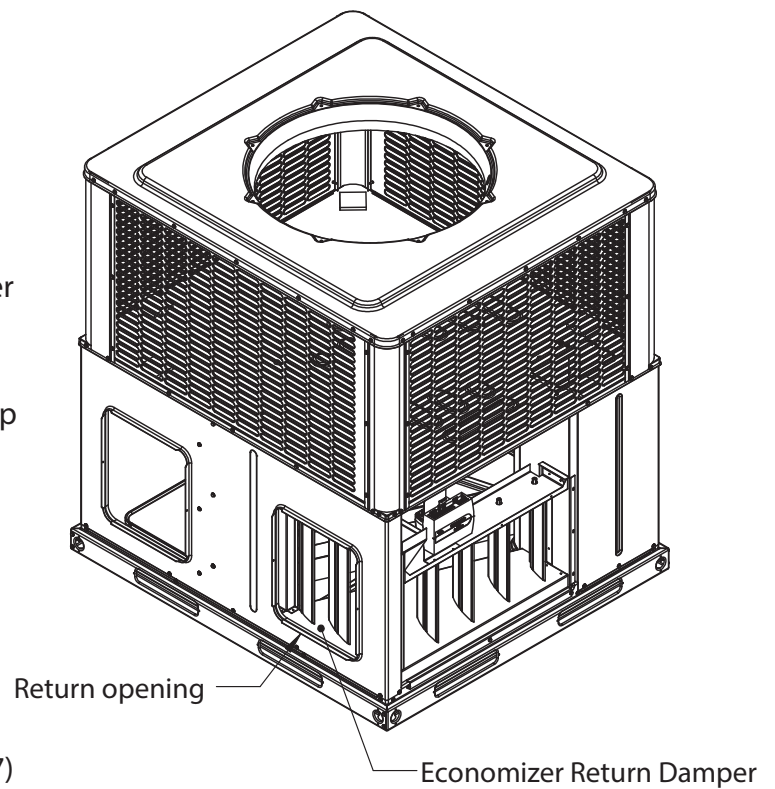

ILL. 4

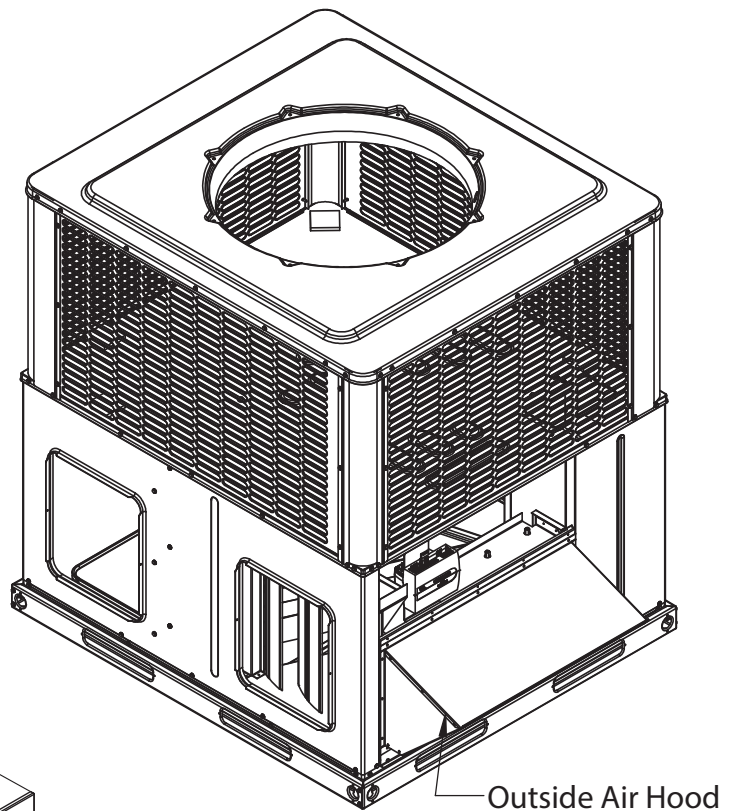

ILL. 5

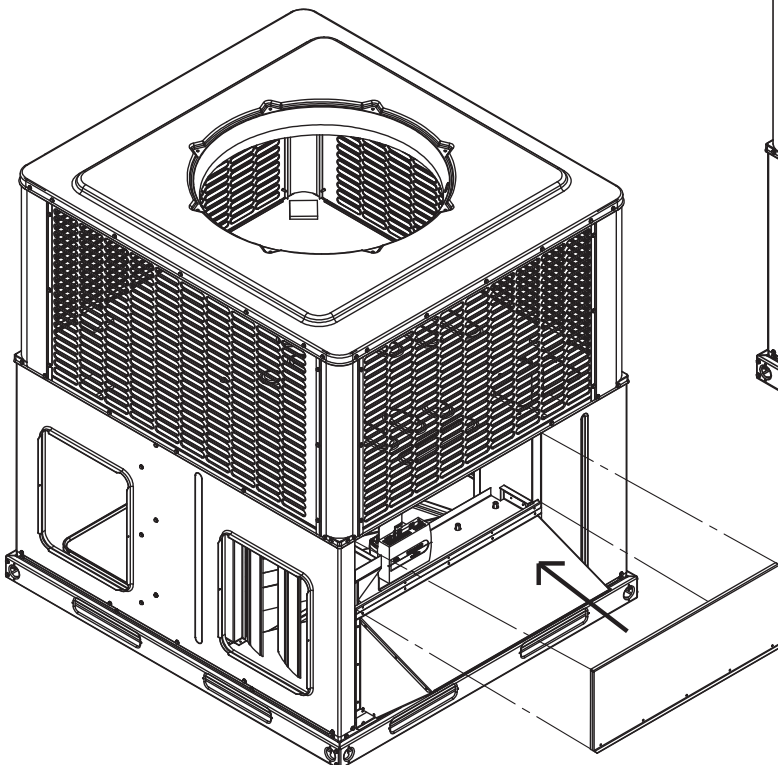

ILL. 6

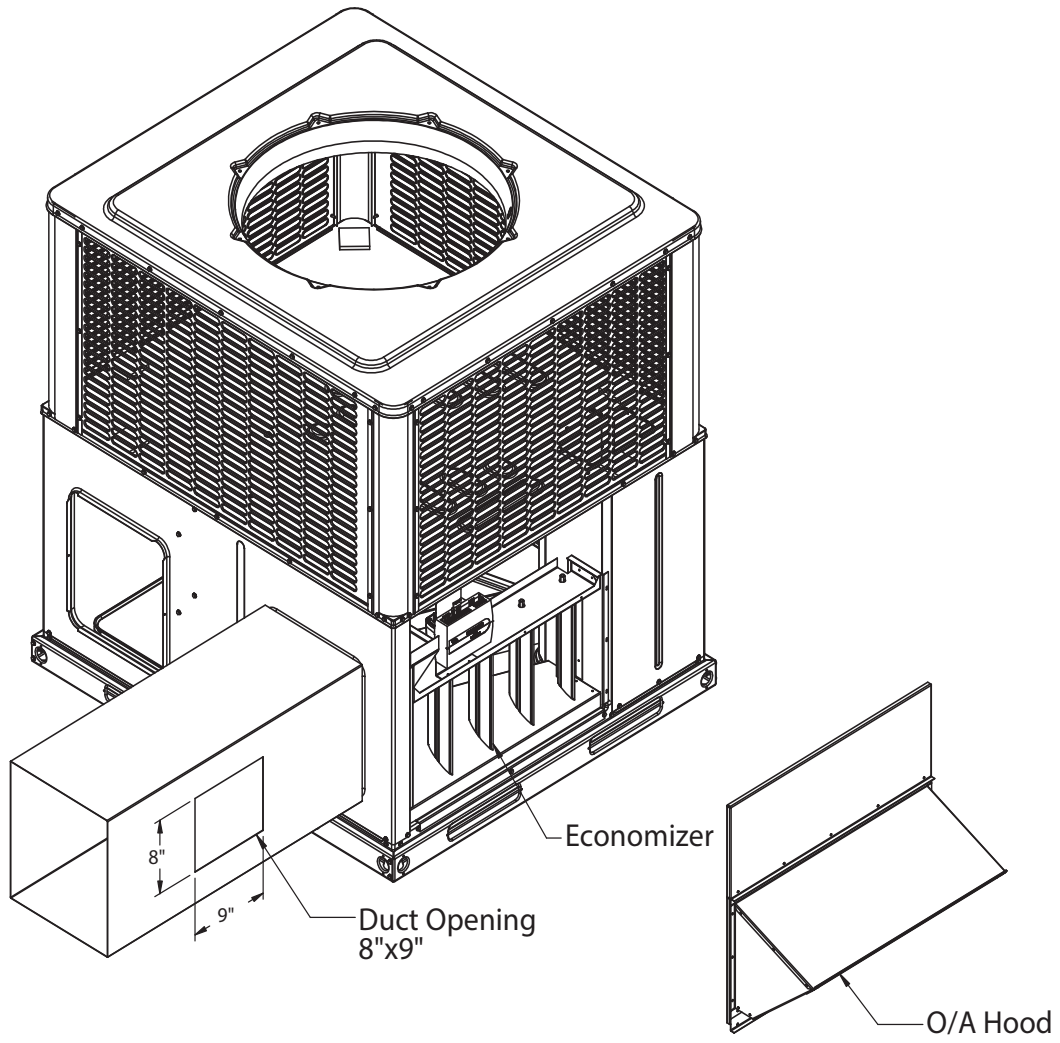

ILL. 7

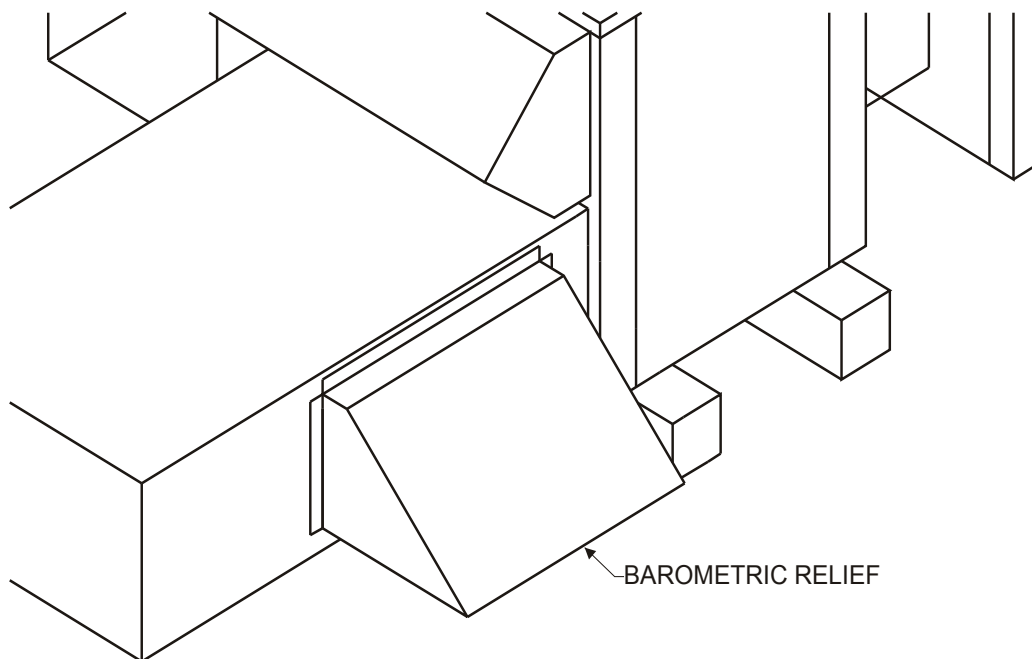

14. Route wiring through existing openings to panel.

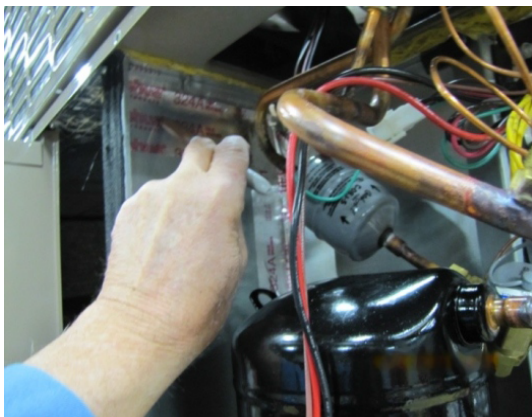

ILL. 8



ILL. 10

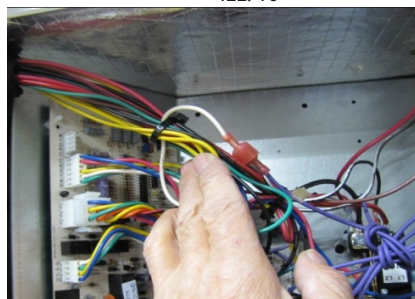

ILL. 11



ILL. 9

15. Place the adhesive backed wiring diagram on the low voltage compartment access panel by the unit diagram. Reinstall low voltage compartment access panel.

16. Turn power on to RTU.

17. For economizers with optional power exhaust, route the power cord through the unit following steps 5 and 6. See wiring diagram notes (ILL. 17- ILL. 19) and follow all electrical codes for connection.

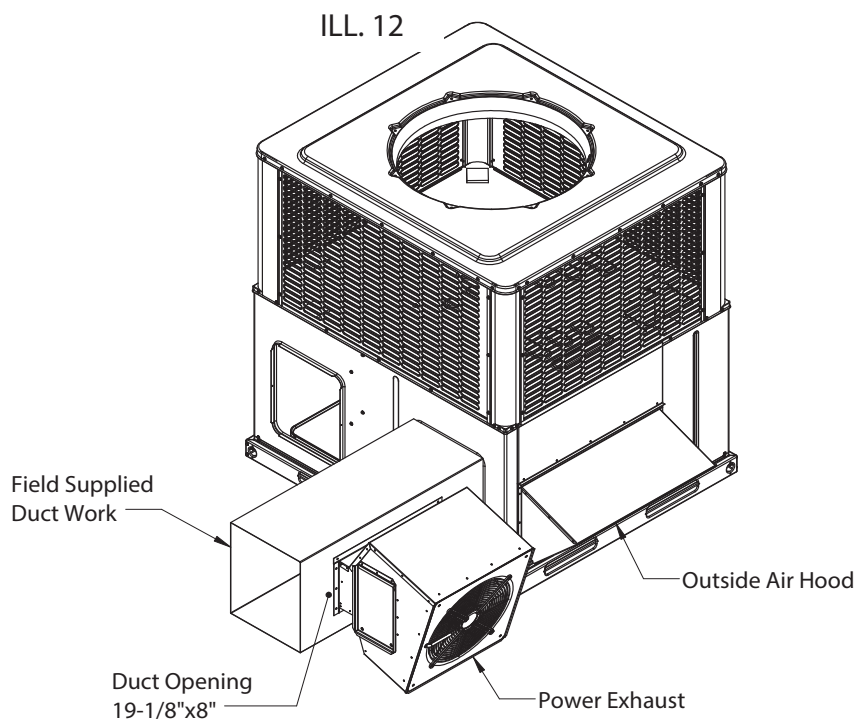

ILL. 13
 Dry Bulb Gas Electric Control Wiring Diagram

LX ECONOMIZER
 DRY BULB CONTROL WIRING DIAGRAM
 GAS ELECTRIC

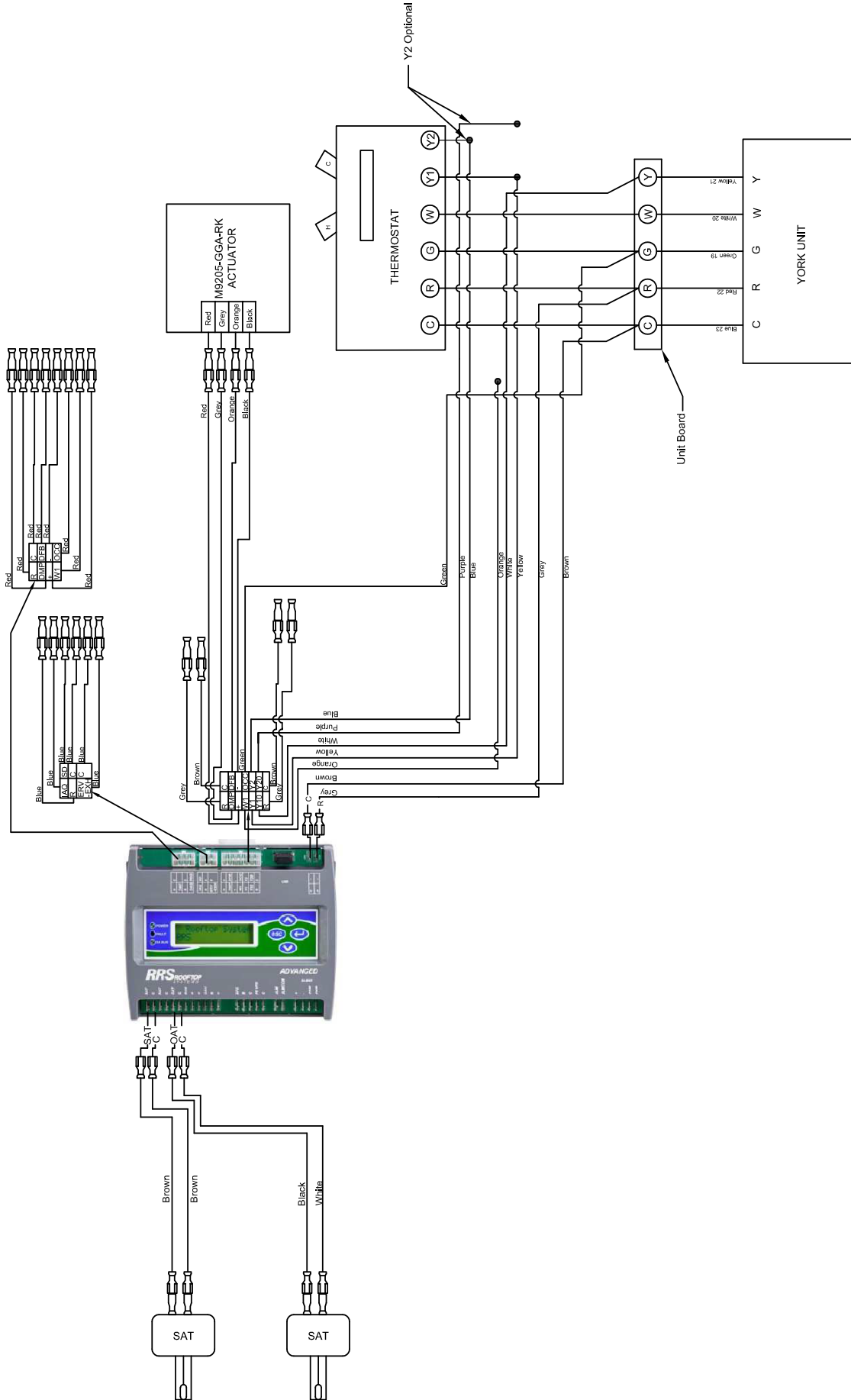

ILL. 14
 Enthalpy Gas Electric Control Wiring Diagram

LX ECONOMIZER
 ENTHALPY CONTROL WIRING DIAGRAM
 GAS ELECTRIC

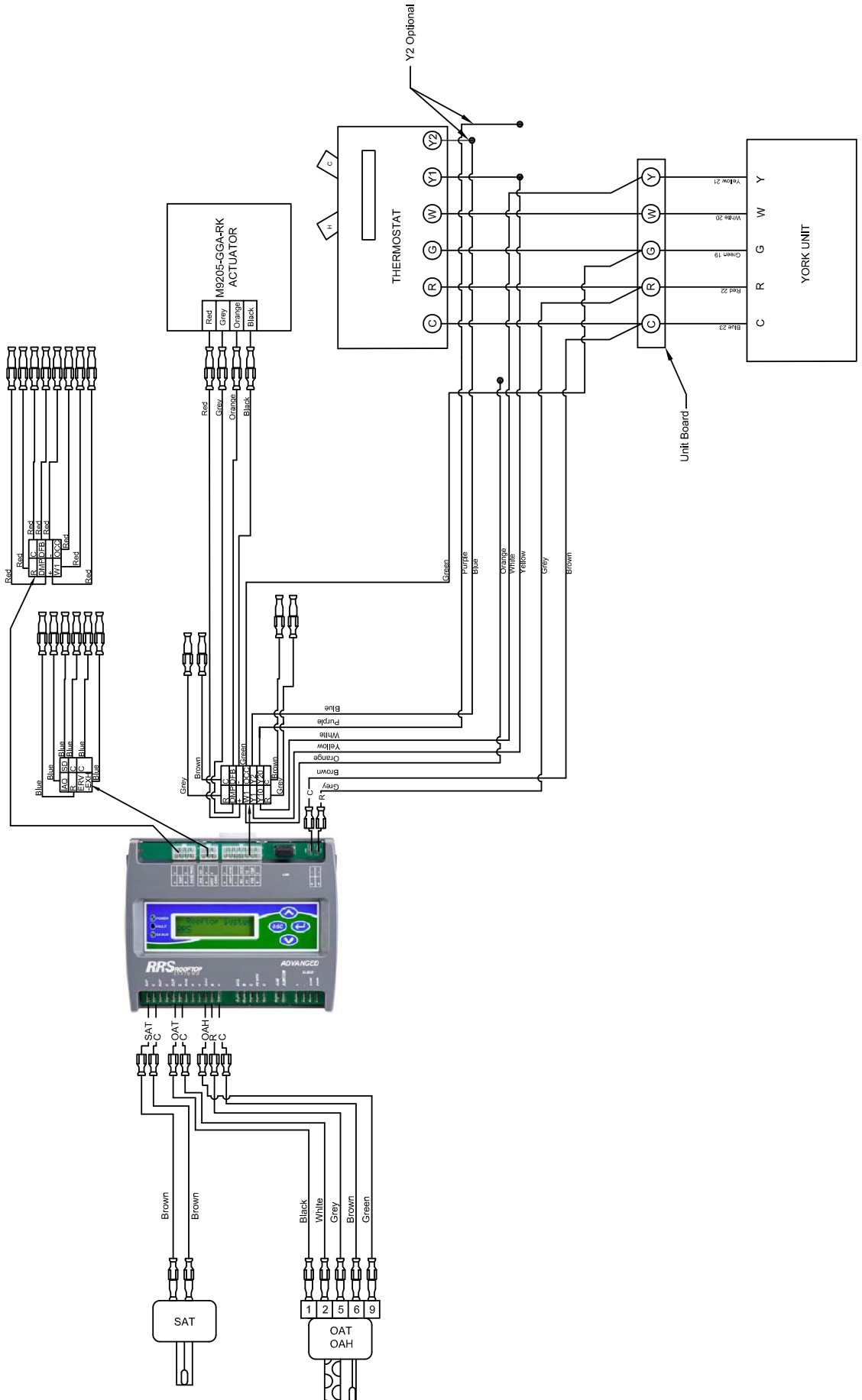

ILL. 15
Dry Bulb Heat Pump Control Wiring Diagram

LX ECONOMIZER
DRY BULB CONTROL WIRING DIAGRAM
HEAT PUMP

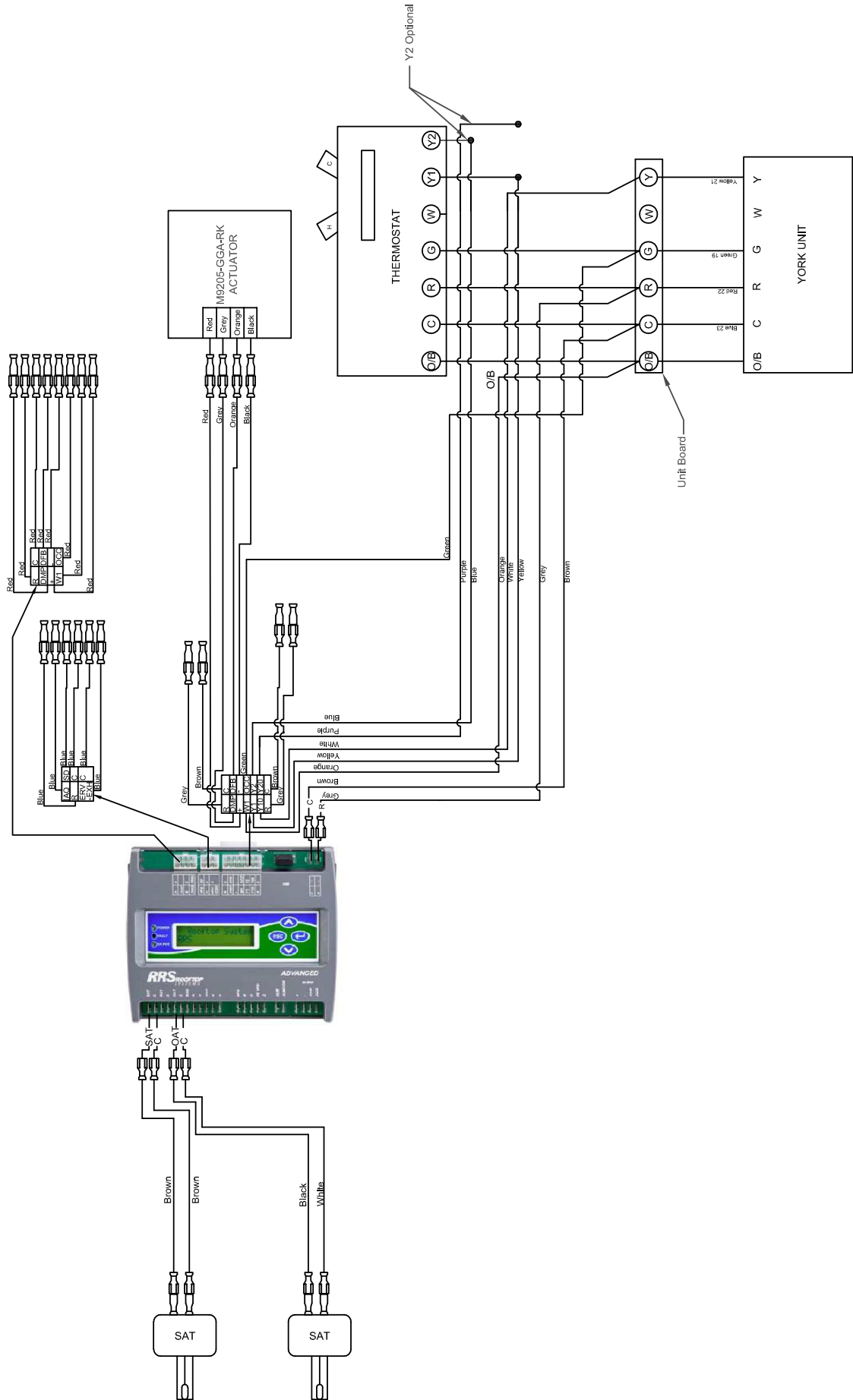

ILL. 16
 Enthalpy Heat Pump Control Wiring Diagram

LX ECONOMIZER
 ENTHALPY CONTROL WIRING DIAGRAM
 HEAT PUMP

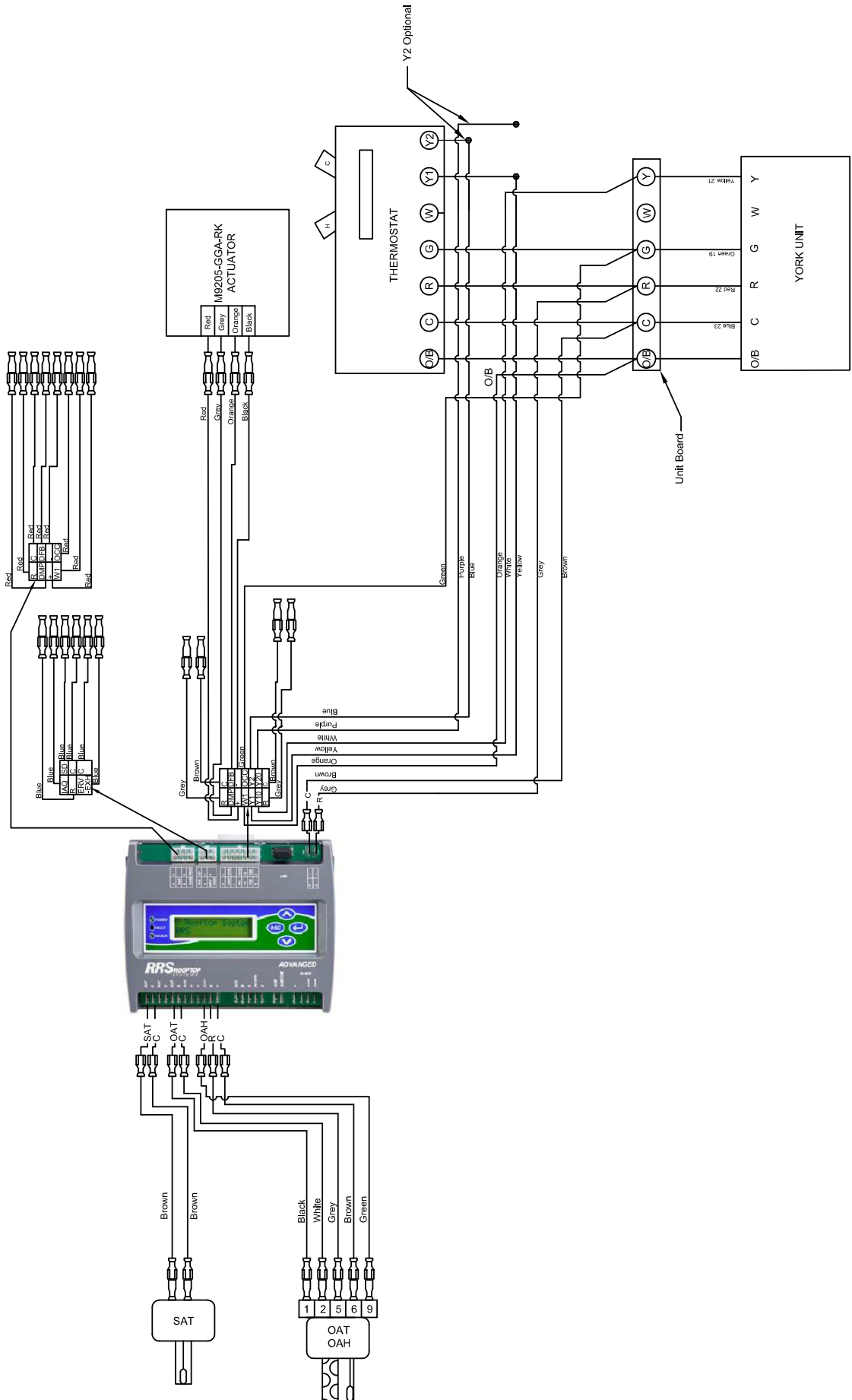

Table 1: Economizer Controller Terminations

Board Name ¹	Description	Type	Termination Type
Analog Inputs (AIs)			
SAT	Supply Air Temperature, C	Resistive	Spade
RAT	Return Air Temperature, C	Resistive	Spade
OAT	Outdoor Air Temperature, C	Resistive	Spade
OAH	Outdoor Air Humidity, R, C	0 to 10 V	Spade
RAH	Return Air Humidity, R, C	0 to 10 V	Spade
IAQ	Indoor Air Quality Input, R, C	0 to 10 V	Pin Connector
BPS*	Bldg Pressure Input, R, C	0 to 10 V	Spade
OAF*	Outdoor Air Flow, R, C	0 to 10 V	Pin Connector
OAQ*	Outdoor Air Quality, R, C	0 to 10 V	Pin Connector
DFB	Damper Feedback Position, C	0 to 10 V	Pin Connector
Analog Outputs (AOs)			
DMP	Damper Output	0 to 10 V	Pin Connector
PE VFD*	PE VFD Output, C	0 to 10 V	Spade
Binary Inputs (BIs)			
Y1O	Y1 Status	24 VAC	Pin Connector
Y2O	Y2 Status	24 VAC	Pin Connector
W1	W1 Status or O/B Status	24 VAC	Pin Connector
SD	Shutdown Status	24 VAC	Pin Connector
PRG*	Purge Status	24 VAC	Pin Connector
OCC	OCC Status	24 VAC	Pin Connector
Binary Outputs (BOs)			
ALM	Alarm Output, Output COM	Relay (dry contact)	Spade
Y1O	Y1 Output	Relay (24 VAC)	Pin Connector
Y2O	Y2 Output	Relay (24 VAC)	Pin Connector
ERV-EXH	Exhaust Fan/ERV Output	Relay (24 VAC)	Pin Connector
Additional Terminations			
R	R (24 VAC Class 2 Supply)	24 VAC	Spade
Board Name¹	Description	Type	Termination Type
C	C (24 VAC Class 2 Common)	24 VAC	Spade
SA Bus*	SA Bus	RS-485 Comm	Spade

1. The * denotes the Inputs and Outputs (I/Os) are only on the Advanced model.

Accessories

Table 2: Accessories

Product Code Number	Description
TE-636GV-2	Temperature Sensor
HE-6862-0N00WS	Temperature/Humidity Sensor
M9205-GGA-YK10	Damper Actuator
CD-W00-x0-1	Space CO ₂ Sensor (recommended)
CD-Pxx-00-0	Duct CO ₂ Sensor (recommended)
RK-WRH1001-0	Wiring Harness

Note: For Outdoor Air (OA) Flow monitoring consult your local Johnson Controls branch or RRS representative to determine the best product to use for your application. Due to the various sensors available for monitoring OA flow, we cannot recommend one specific product.

ILL. 17 - Power Exhaust Modulating Wiring Diagram 460V/3Ph

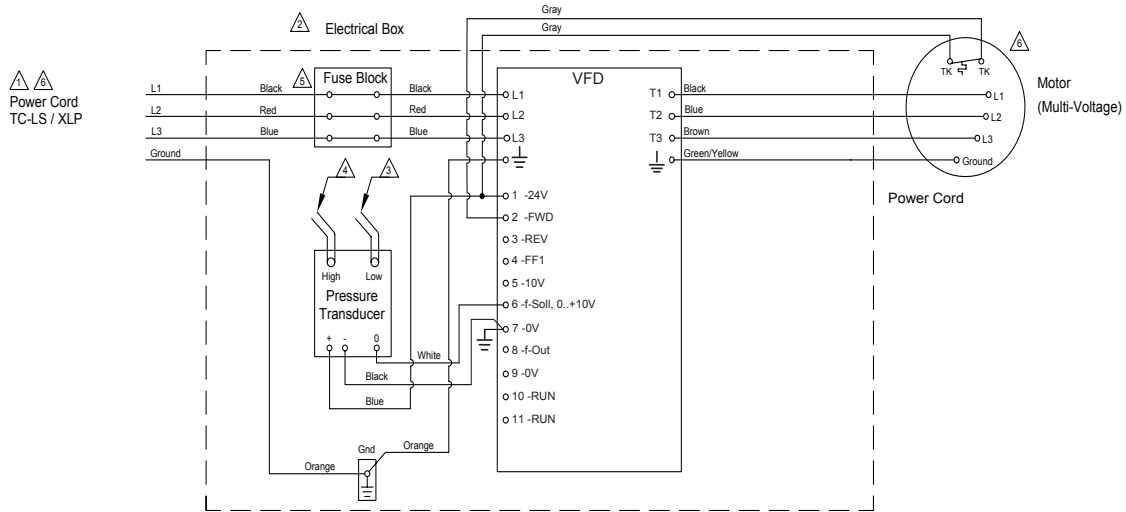

⚠ Power Supply. Provide disconnect means and circuit protection as required. See power exhaust name plate for electrical ratings. If local codes allow connecting to the HVAC unit power, make sure the disconnect and incoming wiring are sized to handle the load of both the HVAC unit and the power exhaust.

To determine MCA with power exhaust: $\text{New MCA} = \text{MCA of Unit Only} + \text{MCA of Power Exhaust}$

- ⚠ Transformer, contactor and fuses to be in a NEMA type electrical enclosure.
- ⚠ Factory mounted 3/16" low pressure tubing.
- ⚠ 25 feet of 3/16" high pressure tubing and connection port provided for field mounting in conditioned space. Architectural finishing field provided. (Follow local codes.)
- ⚠ For fuse size, refer to label on exterior of power exhaust cabinet.
- ⚠ For voltage, refer to label on exterior of power exhaust cabinet.

ILL. 18 - Power Exhaust Modulating Wiring Diagram 230V/3Ph

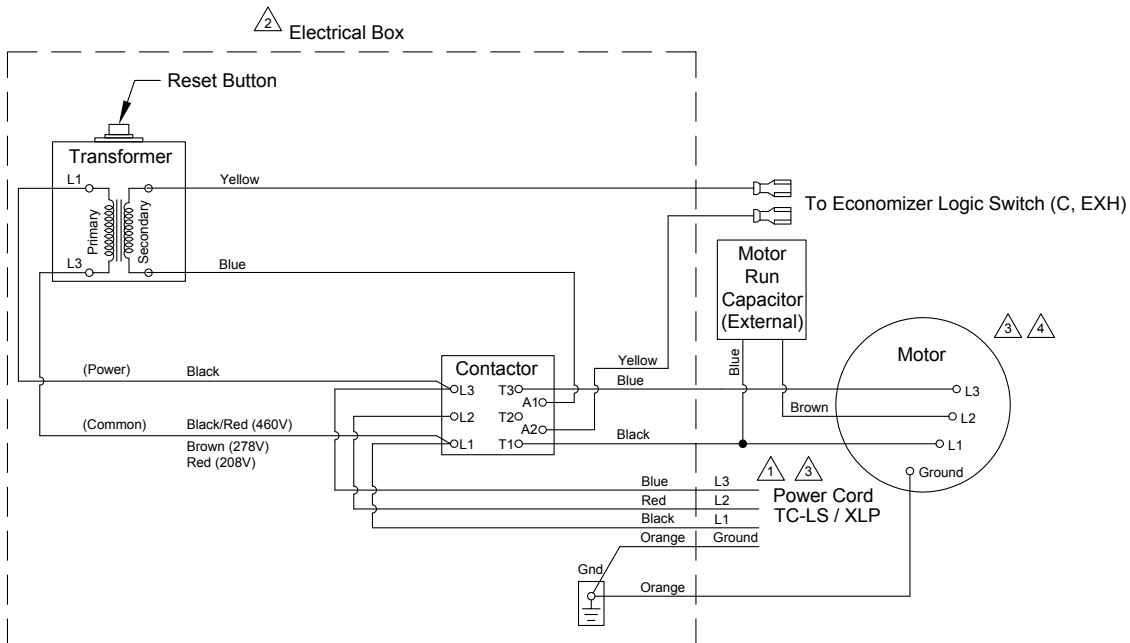

⚠ Power Supply. Provide disconnect means and circuit protection as required. See power exhaust name plate for electrical ratings. If local codes allow connecting to the HVAC unit power, make sure the disconnect and incoming wiring are sized to handle the load of both the HVAC unit and the power exhaust.

To determine MCA with power exhaust: $\text{New MCA} = \text{MCA of Unit Only} + \text{MCA of Power Exhaust}$

- ⚠ Transformer, contactor and fuses are to be in a NEMA type electrical enclosure.
- ⚠ For voltage, refer to label on exterior of power exhaust cabinet.
- ⚠ Motor supplied with internal thermal protection.

ILL. 19 - Power Exhaust Constant Volume Wiring Diagram 230-460V/3Ph

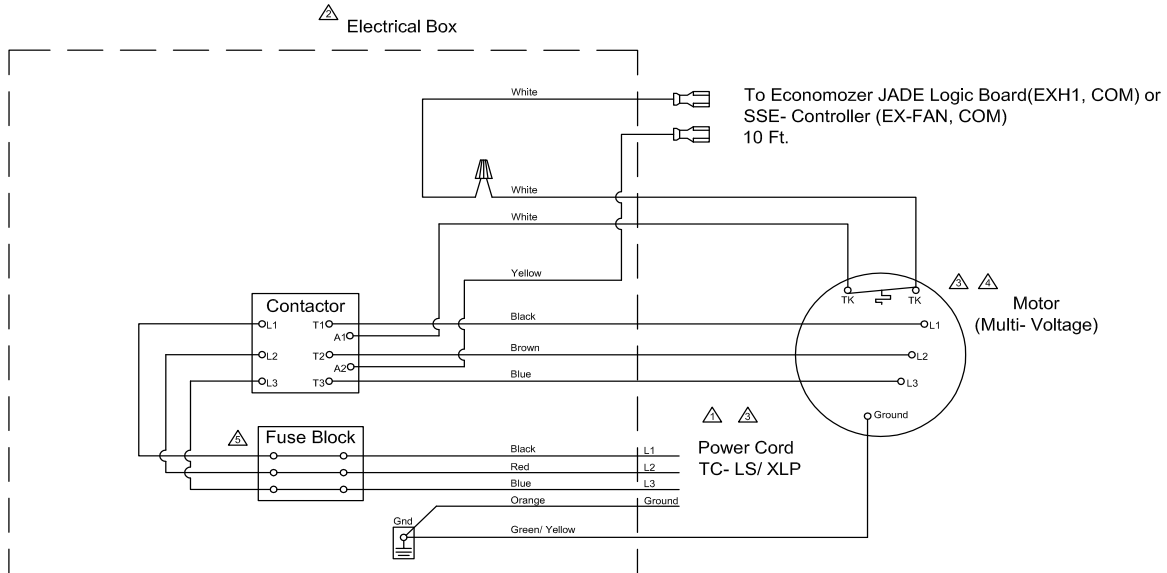

- ⚠ Power Supply. Provide disconnect means and circuit protection as required. See Power Exhaust name plate for electrical ratings. If local codes allow connecting to the HVAC unit power, make sure the disconnect and incoming wiring are sized to handle the load of both the HVAC unit and Power Exhaust.

To determine MCA with power exhaust: $\text{New MCA} = \text{MCA of Unit Only} + \text{MCA of Power Exhaust}$.

- ⚠ Transformer, Contactor, and Fuses are to be in a NEMA type electrical enclosure.
- ⚠ For Voltage, refer to label on the exterior of power exhaust cabinet.
- ⚠ Motor supplied with internal thermal protection.
- ⚠ 1 amp LPCC fuses (460-3Ph). 2 amp LPCC fuses (230V- 3Ph). 3 amp LPCC fuses (230- 1Ph).

ILL. 20 - Power Exhaust Constant Volume Wiring Diagram 230V/1Ph

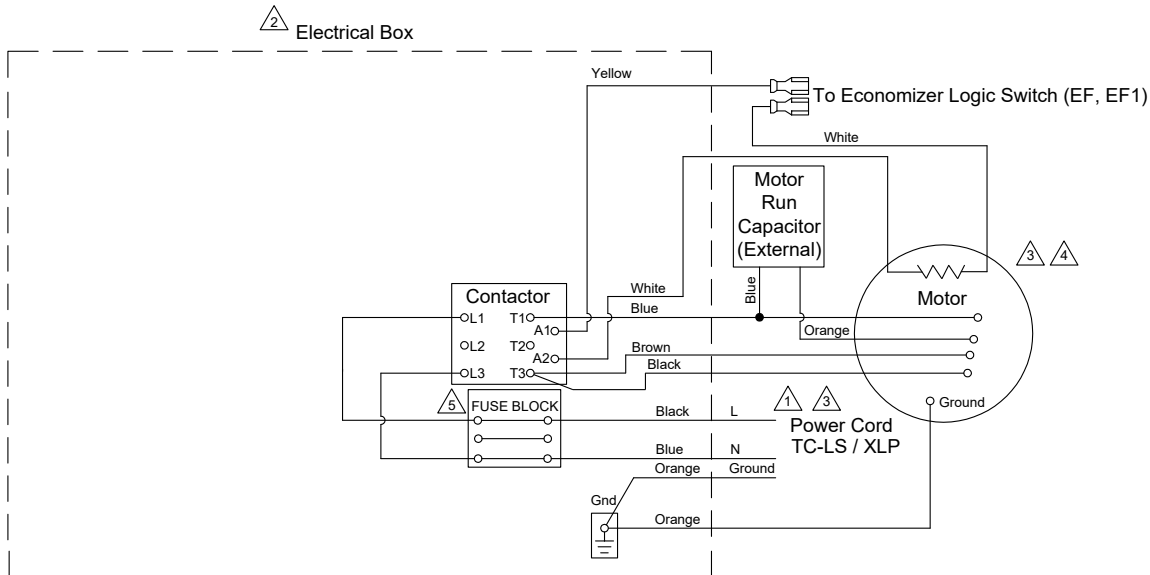

- ⚠ Power Supply. Provide disconnect means and circuit protection as required. See power exhaust name plate for electrical ratings. If local codes allow connecting to the HVAC unit power, make sure the disconnect and incoming wiring are sized to handle the load of both the HVAC unit and the power exhaust.

To determine MCA with power exhaust: $\text{New MCA} = \text{MCA of Unit Only} + \text{MCA of Power Exhaust}$

- ⚠ Transformer, contactor and fuses are to be in a NEMA type electrical enclosure.
- ⚠ For voltage, refer to label on exterior of power exhaust cabinet.
- ⚠ Motor supplied with internal thermal protection.
- ⚠ For fuses, refer to label on exterior of power exhaust cabinet.

ILL. 21 - Power Exhaust Modulating Wiring Diagram 230V/1Ph

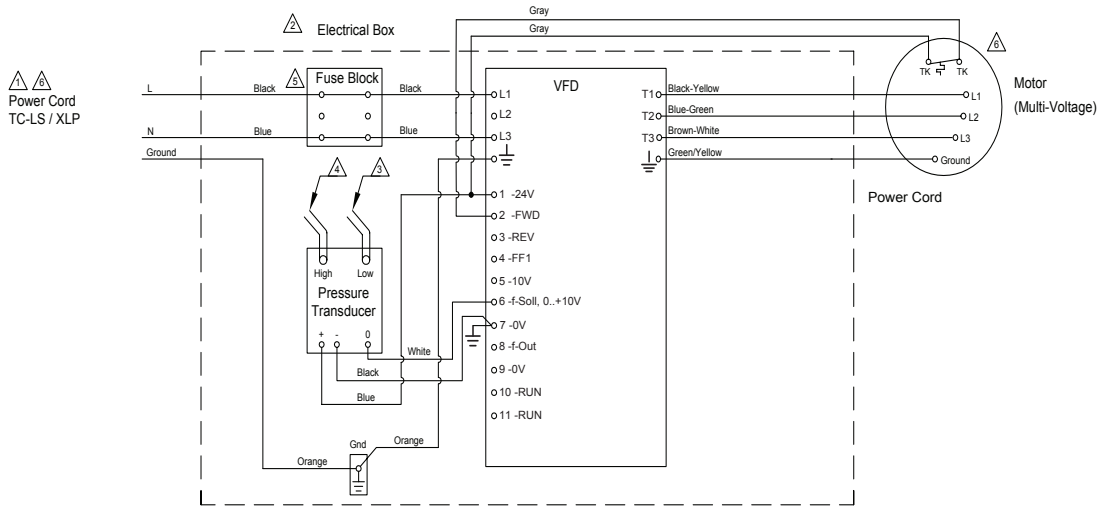

⚠ Power Supply. Provide disconnect means and circuit protection as required. See power exhaust name plate for electrical ratings. If local codes allow connecting to the HVAC unit power, make sure the disconnect and incoming wiring are sized to handle the load of both the HVAC unit and the power exhaust.

To determine MCA with power exhaust: $\text{New MCA} = \text{MCA of Unit Only} + \text{MCA of Power Exhaust}$

⚠ Transformer, contactor and fuses to be in a NEMA type electrical enclosure.

⚠ Factory mounted 3/16" low pressure tubing.

⚠ 25 feet of 3/16" high pressure tubing and connection port provided for field mounting in conditioned space. Architectural finishing field provided. (Follow local codes.)

⚠ For fuse size, refer to label on exterior of power exhaust cabinet.

⚠ For voltage, refer to label on exterior of power exhaust cabinet.

Example: With a unit that has $\text{MCA}=22.5$ amps and $\text{MOCP}=30$ amps,

$\text{New MCA} = 22.5 \text{ amps} + 3 \text{ amps (example for power exhaust)} = 25.5 \text{ amps}$

If New MCA is less than MOCP for the HVAC unit, you can tie the power wire to the HVAC contactor terminal strip, if local code allows. Make sure tap off terminal block is capable for handling more than one unit.

If new MCA is greater than MOCP or local code requires, you must run power wire for the power exhaust to an external disconnect. Make sure the disconnect is sized properly for the power from the power exhaust as well as the HVAC unit.

Getting Started

Check Power and LED Sequence

The controller start-up sequence begins after 24 VAC power is applied to Terminals R and C. The red Fault LED flashes and the green SA Bus LED lights briefly. The SA Bus light flashes when either the MAP Gateway or compatible sensors are also connected.

Thermostat Communication

Verify the 2-stage thermostat occupied terminal is connected to the OCC terminal on the board. You can jump the OCC terminal to the FAN Demand (G) terminal for permanent override (if OCC is unavailable or the building is occupied constantly). Without the OCC input, the economizer never opens.

Gather Information

- Obtain the required minimum position damper position (default 10%), or use the outdoor air CFM divided by the Supply CFM to obtain the %.
- Is the unit conventional or a heat pump?
- Does the job require California Title 24 Certification?

Programming Keys

Use the local LCD to complete programming the economizer. Use the arrows to move between the menu options. Pressing Enter selects a submenu or allows you to edit the selected value. After you enter a value, press Enter to confirm the change.

Setting Initial Parameters

All parameters can be located under:

Details > Service > Factory >

- Scroll to the Details Menu, press Enter.
- Select Service, press Enter.
- Select Factory, press Enter.

Select Damper Minimum Position

- The current setting appears, press Enter. The screen flashes.
- Set parameter to the value. Press Enter to confirm.

Select Equipment Type

- Select conventional or Heat Pump > press Enter.

Select T-Stat Type

- Current Setting appears > press Enter.
- **Select W for Conventional.**
- **Select O or B for Heat Pump** depending on the unit.

Title 24 Fault Detection- Under Different Menu

- Commissioning > General > Fault Detected Enable >

Setting Initial Parameters (Cont.)

- Current setting appears, press Enter.
- Factory Default (Enable).

Note: Enable the Title 24 setting if it is required for your application.

Setting Advanced Parameters

Dry Bulb Set point (if equipped)

- Details > Control > Econ > Set Up > Dry Bulb Set point
- Default- 68°
- Press Enter to adjust the desired Set Point with the up or down keys, then press Enter again to save the Setpoint.

OA Enthalpy Setpoint (if Equipped)

- Details > Control > Econ > Setup > OA Enthalpy Setpoint
- Default- 27 Btu/ lb
- Press Enter to adjust the desired setpoint with the up or down keys, then press Enter again to save the setpoint.

Demand Ventilation (if Equipped)

- Details > Service > Factory > Vent Mode
- Default- Disabled
- Controlled by IAQ (IAQ input required)
- Difference between IAQ and OAQ (IAQ and OAQ inputs required)
- Details > Controls > DVent > Vent Max Pos (Demand Ventilation Maximum Economizer)
- Details > Control > DVent > VentIAQ Setpoint (Demand Ventilation Indoor Air Quality)

Two Speed Fan only

- Details > Control > DVent > Vent Min Pos Lo (Demand Ventilation Min Position Low Speed Fan)
- Details > Control > DVent > Vent Min Pos Hi (Demand Ventilation Min Position High Speed Fan)

Exhaust Fan (if Equipped)

- Details > Service > Factory > Exhaust Setup >
- Default- None
- Non Modulating Control
- Variable Frequency Fan
- ERV
- Details > Setpoints > Damper % Fan Off/ On
- Select Economizer Damper Position for Exhaust Fan to Turn Off > press Enter.

Getting Started (cont.)

Setting Initial Parameters (Cont.)

Exhaust Fan (if Equipped) cont.

- Economizer Damper Position for Exhaust Fan to Turn On > press Enter.

Airflow Monitoring Station Setup (if Equipped)

- Details > Service > Factory > Fresh Air Enable > On
- Details > Controls > AirMonStation > Fresh Air Flow

Run Acceptance Test

- To Run: Self-Test > Self-Test Start > All Test Acceptance Test
- Damper Position: The damper test commands the damper output to 100%. The test is satisfied when the feedback signal reads 98% or greater. The next part of this test commands the damper to 0% and checks for a feedback signal of 2% or less.
- Title 24: The California Title 24 test runs all required diagnostics to certify the unit per NRCA-MCH-05-A form.
- Prompts confirm verification, so pay attention to the screen during the acceptance test.

Table 4: Commission View Submenus (Part 1 of 5)

Level 1	Level 2	Level 3 ¹ (LCD Screen Name)	Level 4 ² (Default Values)	Available Values
Alarms	Outputs Disabled Due to Low Input V			
	Outputs Limited Due to Brownout Input V			
	Building Pressure Sensor Failure			
	Outdoor Air Temperature Sensor Failure			
	Return Air Temperature Sensor Failure			
	Supply Air Temperature Sensor Failure			
	Econ Controller Calibration Error			
	Return Air Humidity Sensor Failure			
	Outdoor Air Humidity Sensor Failure			
	Indoor Air Quality Sensor Failure			
	Outdoor Air Quality Sensor Failure			
	Low Outdoor Air Temperature Cooling Cutout			
	Economizer Letting In Excess Outdoor Air			
	Unit has Recieved a Purge Request			
	Excessive Supply Air Temp Cooling			
	Fresh Air Intake Sensor Failure			
	Air Temperature Sensor Failure			
	Econ Economizing When It Should Not			
	Econ Not Economizing When It Should			
	Economizer Damper Not Modulating			
Economizer Letting In Excess Outdoor Air				

Table 4: Commission View Submenus (Part 2 of 5)

Level 1	Level 2	Level 3 ¹ (LCD Screen Name)	Level 4 ² (Default Values)	Available Values
Summary Menu	Economizer	Supply Temp	Sensor Input Reading	-40 to 150°F
		Return Temp	Sensor Input Reading	0 to 140°F
		Outdoor Temp	Sensor Input Reading	-40 to 140°F
		Return Humidity	Sensor Input Reading	5 to 100%
		Indoor Quality	Sensor Input Reading	250 to 2,000 ppm
		Damper Command	15%	0 to 100%
		Damper Feedback	Sensor Input	0 to 100%
		Free Clg Avail	Dependent on Conditions	Yes, No
		Dry Bulbs	68°F (20°C)	40 to 80°F
		OA Enth Setpt	27 BTU/lb	10 to 50 BTU/lb
		High OA Shutoff	75°F (24°C)	0 to 86°F
	Power Exhaust	Damper Command	15%	0 to 100%
		Damper % Fan Off	20%	0 to 100%
		Damper % Fan On	60%	0 to 100%
		Exhaust Setup	Non-modulating Control	None, ERV, Variable Frequency Fan, Non-modulating Control
		Exhaust Fan	0%	0 to 100%
		Exhaust Comment		
		Bldg Pressure	Sensor Input Reading	-0.25 to 0.25 w.c. inches
		Bldg Pressure Stpt	0.1	-0.25 to 0.25 w.c. inches
	Compressor	Compressor 1	Off	Off/On
		Compressor 2	Off	Off/On
		Compressor Stage Accumulated Runtime 1	0 minutes	10,000 minutes
		Compressor Stage Accumulated Runtime 2	0 minutes	10,000 minutes

Table 4: Commission View Submenus (Part 3 of 5)

Level 1	Level 2	Level 3 ¹ (LCD Screen Name)	Level 4 ² (Default Values)	Available Values
Commission	General	Economizer Enabled (Econ Enable)	True	True or False
		Compressor Enable (Comp Enable)	True	True or False
		Compressor 1 Lockout (Comp 1 Lockout)	False	True or False
		Compressor 2 Lockout (Comp 2 Lockout)	False	True or False
		Fault Detect Enable	True	True or False
		Supply Temperature Setpoint (Supply Temp Stpt)	55°F	38 to 70°F
		Damper Percent Fan Off (Damper % Fan Off)	60%	0 to 100%
		Damper Percent Fan On (Damper % Fan On)	20%	0 to 100%
		Building Pressure Setpoint (Bldg Pressure Stpt)	0.1 in. w.c.	-0.25 to 0.25 in. w.c.
		Low Ambient Lockout Enable (Low Ambient En)	Yes	Yes or No
		Low Ambient Setpoint (Low Ambient Stpt)	45°F	-45 to 80°F
		Dry Bulb Setpoint (Dry Bulb Stpt)	68°F	35 to 86°F
		Outdoor Air Enthalpy Setpoint (OA Enth Stpt)	27 Btu/lb	10 to 50 Btu/lb
		High Outdoor Air Shutoff (High OA Shutoff)	75°F	0 to 86°F
		Free Cooling Select (Free Clg Stpt)	Auto	Dry Bulb, Single Enthalpy, Dual Enthalpy, Auto
		Exhaust Proportional Band (Exhaust Prop Band)	N/A	N/A
		Exhaust Integral time (Exhaust Int Time)	N/A	N/A
		Damper Proportional Band (Damper Prop Band)	N/A	N/A
		Damper Integral Time (Damper Int Time)	N/A	N/A

Table 4: Commission View Submenus (Part 4 of 5)

Level 1	Level 2	Level 3 ¹ (LCD Screen Name)	Level 4 ² (Default Values)	Available Values
Commission (Cont.)	Calibrate	Supply Air Temperature Offset (SAT Offset)	0	-5 to 5°F
		Supply Temperature (Supply Temp)	N/A	N/A
		Return Air Temperature Offset (RAT Offset)	0	-5 to 5°F
		Return Temperature (Return Temp)	N/A	N/A
		Outdoor Air Temperature Offset (OAT Offset)	0	-5 to 5°F
		Outdoor Temperature (Outdoor Temp)	N/A	N/A
		Outdoor Air Humidity Offset (OAH Offset)	0	-5 to 5°F
		Outdoor Humidity	N/A	N/A
		Return Air Humidity Offset (RAH Offset)	0	-5 to 5°F
		Return Humidity	N/A	N/A
		Indoor Air Quality Offset (IAQ Offset)	0	-5 to 5°F
		Indoor Quality	N/A	N/A
		Building Static Pressure Offset (BSP Offset)*	0	-0.05 to 0.05 in.w.c.
		Building Pressure (Bldg Pressure)*	N/A	N/A
		Fresh Air Intake Offset (FAI Offset)*	0	-100 to 100 cfm
		Fresh Air Flow*	N/A	N/A
		Outdoor Air Quality Offset (OAQ Offset)	0	-100 to 100 ppm
		Outdoor Quality	N/A	N/A
		Damper Minimum Voltage (Damper Min Value)	2 VDC	0 to 2 VDC
		Damper Feedback Minimum Voltage (Feedback Min Value)	2 VDC	0 to 2 VDC
Fresh Air Range*	10,000 cfm	0 to 50,000 cfm		
Controller	Brightness Setting	5		3 to 10
	Firmware Version		1.0.0.0139	≥ 1.0.0.0139
	Firmware Status		Ok	N/A
	Language		English	
	Units		IP	IP/SI

Table 4: Commission View Submenus (Part 5 of 5)

Level 1	Level 2	Level 3 ¹ (LCD Screen Name)	Level 4 ² (Default Values)	Available Values
Update Menu	View Version	1.0.0.0139 Firmware Ok	N/A	N/A
	Load Firmware	(displays list of choices to be loaded)	N/A	N/A
	Backup	Backup: Wait, Backup 0% Backup: Ok, Backup 0%	N/A	N/A
	Retore	BackupConfig (file name to be restored)	N/A	N/A
	Full Clone	No Full Clone	N/A	N/A
	Partial Clone	No Partial Clone	N/A	N/A
	Factory Default	Does not Display	N/A	N/A
	Time	Does not Display	N/A	N/A
	Export Trend	Exporting	N/A	N/A
	Self Test Report	Export Done	N/A	N/A
Details			N/A	N/A
Self Test Menu	Self Test Status		Off Not Run: 0 min	N/A
	Self Test Start	All Test/Equipment Test/ Acceptance Test	(all test) Confirm esc = No ent-yes	N/A
	Equipment Test	(all Test) Confirm esc = No ent-yes	N/A	N/A
	Acceptance Test	(all Test) Confirm esc = No ent-yes	N/A	N/A
	Self Test Pause		N/A	N/A
	Self Test Cancel		N/A	N/A
	Self Test Reset		N/A	N/A

1. The * denotes the Inputs and Outputs (I/Os) are only on the Advanced model.
2. NA rows denote monitor-only points.

Common Settings

- Setting Damper Minimum Position
(Details > Setpoint > Damper Minimum Position)
- Setting Equipment Type (Details > Unit > Equipment Type > Enter)
- Setting Thermostat Type (Details > Unit > Thermostat Type [W, O, or B])

Menu Conditions

Table 5: Menu Conditional Variables (Part 1 of 2)

Menu Item	Condition for Parameter to Appear on Menu
Exhaust Setup	Advanced Model
Damper Position for Exhaust Fan to Turn On	Exhaust Setup Set to Non-Modulating Control and Supply Fan Setup Set to Single Speed
Damper Position for Exhaust Fan to Turn Off	Exhaust Setup Set to Non-Modulating Control and Supply Fan Setup Set to Single Speed
Building Static Pressure Setpoint	Exhaust Setup Set to Variable Frequency Fan
Low Ambient Lockout Enabled	Equipment Type Set to Conv RTU
Low Ambient Setpoint	Equipment Type Set to Conv RTU and Low Ambient Lockout Enabled
Supply Fan Type	Equipment Type Set to Conv RTU
Low Ambient Economizer Setpoint	Damper Low Ambient Set to Enabled
Low Ambient Economizer Minimum Position	Damper Low Ambient Set to Enabled
Economizer Damper Minimum Position Low Speed Fan	Supply Fan Type Set to two-Speed and DCV Set to Disabled
Demand Ventilation Maximum Economizer Position	DCV Not Equal to Disabled
Demand Ventilation Indoor Air Quality Setpoint	DCV Not Equal to Disabled
Fresh Air Intake Setpoint	Advanced and Fresh Air Intake Enabled
Fresh Air Intake Enable	Advanced Model
Demand Ventilation Mode of Operation	Advanced Model
DCV Economizer Damper Minimum Position Low Speed Fan	Supply Fan Type set to Two-Speed and DCV not equal to Disabled
DCV Economizer Damper Minimum Position High Speed Fan	Supply Fan Type set to Two-Speed and DCV not equal to Disabled
Damper Position for Exhaust Fan to Turn Off Low Speed Fan	Exhaust Setup Set to Non-Modulating Control and Supply Fan setup not equal to single-speed
Damper Position for Exhaust Fan to Turn On Low Speed Fan	Exhaust Setup Set to Non-Modulating Control and Supply Fan setup not Equal to single-speed
Compressor 2 Lockout	#Compressors > 1
Compressor 2 Test	#Compressors > 1
Power Exhaust Test	Power Exhaust Test Set to Non-Modulating Control
ERV Pivot Test	Exhaust Setup Set to ERV
Exhaust VFD Test	Exhaust Setup Set to Variable Frequency Fan
OA Vent Test	Advanced and Fresh Air Intake Enable
DCV Test	DCV Not Equal to Disabled
SAT Offset	SAT Sensor Connected
RAT Offset	RAT Sensor Connected
OAT Offset	OAT Sensor Connected
OAH Offset	OAH Sensor Connected
RAH Offset	RAH Sensor Connected
IAQ Offset	IAQ Sensor Connected
BSP Offset	BSP Sensor Connected
FAI Offset	FAI Sensor Connected

Table 5: Menu Conditional Variables (Part 2 of 2)

Menu Item	Condition for Parameter to Appear on Menu
OAQ Offset	OAQ Sensor Connected
Fresh Air Range	Advanced Model and Fresh Air Intake Enabled
Exhaust Setup Basic	Basic Model
DCVModeBasic	Basic Model
Damper Position For Exhaust Fan to Turn Off High Speed Fan	Exhaust Setup Set to Non-Modulating Control and Supply Fan Setup Not Equal to Single Speed
Damper Position for Exhaust Fan to Turn On High Speed Fan	Exhaust Setup Set to Non-Modulating Control and Supply Fan Setup Not Equal to Single Speed
Exhaust Fan VFD Percent Command	Exhaust Setup Set to Variable Frequency Fan
Compressor Stage 2 Command	#Compressors > 1
Exhaust Fan Command	Exhaust Setup Not Equal to None
Exhaust Control Determination State	Exhaust Setup Not Equal to None
Exhaust Control Mode	Exhaust Setup Not Equal to None
Exhaust Control State	Exhaust Setup Not Equal to None
Demand Ventilation Status	DCV Not Equal to Disabled
Fresh Air Intake Control Active	Advanced model and Fresh Air Intake Enable
Compressor Stage 2 Status	#Compressors > 1
Exhaust Fan Status	Exhaust Setup Set to Non-Modulating Control and Exhaust Setup Set to Variable Frequency Fan
ERV Status	Exhaust Setup Set to ERV
Exhaust Prop Band	Exhaust Setup Set to Variable Frequency Fan
Exhaust Integral Time	Exhaust Setup Set to Variable Frequency Fan
Compressor 2 Test Status	#Compressors > 1
Power Exhaust Test Status	Exhaust Setup Set to Non-Modulating Control
ERV Pivot Test Status	Exhaust Setup Set to ERV
Exhaust VFD Test Status	Exhaust Setup Set to Variable Frequency Fan
OA Vent Test Status	Fresh Air Intake Enabled
DCV Test Status	DCV Not Equal to Disabled
C2 Runtime	#Compressors > 1

Self Test

The RRS Economizer performs a self test to ensure proper operation. The Basic and Advanced tests both verify configuration, inputs and outputs; and on the Advanced model, an Acceptance Test for Title 24 compliance. You can select the specific test you would like to run for troubleshooting.

Basic Model Operation

The self test has a stabilization period to drive all the outputs to OFF or 0%. The active period energizes the equipment. The VFD or Supply Fan may run throughout both the stabilization and active periods.

UI Inputs and Outputs

To begin a self-test, navigate to Self-Test > Self-Test Start. You can choose between the three options: All Test, Equipment Test, and Acceptance Test.

See Table 1 for a list of the possible outputs. Table 6 shows the expected output states of the self-test.

Damper Test

The damper test commands the damper output to 100%. The test is satisfied when the feedback signal reads 98% or greater. The next part of this test commands the damper to 0%, and checks for a feedback signal of 2% or less. This portion of the test is satisfied when the feedback is 2% or less. If both conditions occur, the test passes. Possible results include: Fail - Damper not responding or Pass.

Alarm Test

An alarm is issued to a specific output. You must respond to the prompt or the alarm prompt time expires. The alarm output is deactivated and the test ends. Possible results include: Fail - Alarm not acknowledged or Pass.

Compressor Tests 1 and 2

The compressor tests are available when OCC signal is Occupied. The output (Y1 or Y2) activates and turns on the compressor. If the supply air temperature decrease by 2°F or more during the check, the output deactivates, and the test passes. Possible results include: Fail - Shut Down Status, Warning - Supply Air Temperature not Dropped, and Pass.

Power Exhaust Test

This test is only available if the Damper Test Passes. The damper opens and the exhaust fan output activates. After the fan activates, you must respond to a prompt to acknowledge that the exhaust fan energized. Upon a response to the prompt or when the prompt timer expires, the exhaust fan is de-energized. Possible results include: Fail - Prompt Respond Not Received, Warning - Exhaust Fan Not Acknowledged, or Pass.

Power Exhaust Test (non-VFD)

This test is only available when the Damper Test passes. The damper opens and has time to respond. The exhaust fan VFD ramps from 0% (off) to 100%. After the exhaust fan energizes, the building static pressure should drop 0.050 in. w.c. or greater. If this does not happen, you must acknowledge that a fan is running. The test passes if the building static pressure decreases. The fan turns off and the test ends after you respond to the prompt. Possible results include: Fail - Prompt Response Not Received, Warning - Exhaust Fan Not Acknowledged, or Pass.

ERV Pivot Test

This test activates the energy recovery wheel. You must respond to the prompt before the prompt timer expires. Upon prompt response, or an expiration of the prompt timer, the ERV pivot output deactivates and the test ends. Possible results include: Fail - Prompt Response Not Received, Fail - Alarm Not Acknowledged or Pass.

Table 6 shows the expected output states of the self-test.

Table 6: Output States During the Self-Test

Test/Output	Y1	Y2	Exhaust Fan	ERV	Damper	Alarm
Alarm	Off	Off	Off	Off	0%	On
Compressor 1	On	Off	Off	Off	0%	Off
Compressor 2	Off	On	Off	Off	0%	Off
Power Exhaust Test	Off	Off	On/Ramp	Off	0%	Off
ERV Pivot Test	Off	Off	Off	On ¹	0%	Off
Damper Test	Off	Off	Off	Off	Ramp Open; Ramp Close	Off

1. On the advanced model, ramp with the Exhaust Fan VFD available, otherwise the Exhaust fan is On.

Advanced Model Operation

UI Inputs and Outputs

To begin a self-test, navigate to Self-Test > Self-Test Start. You can choose between the three options: All Test, Equipment Test, and Acceptance Test.

See Table 1 for a list of the possible outputs. Table 6 shows the expected output states of the self-test.

Power Exhaust Test (VFD)

This test is only available when the Damper Test passes. The damper opens and has time to respond. The exhaust fan VFD ramps from 0% (off) to 100%. If a building static pressure reading is available, it is monitored during this ramp-up period. The test passes if the building static pressure decreases. If the building static pressure sensor is not available, you must respond to the alarm and confirm the VFD operation. The VFD turns off and the test ends after you respond to the prompt. Possible results include: Fail - Damper not responding, Warning - Exhaust VFD not acknowledged, Warning - Building Static Pressure not dropped, or Pass.

Power Exhaust Test (non-VFD)

This test is only available when the Damper Test passes. The damper opens and has time to respond. The exhaust fan VFD ramps from 0% (off) to 100%. After the exhaust fan energizes, the building static pressure should drop 0.050 in. w.c. or greater. If this does not happen, you must acknowledge that a fan is running. The test passes if the building static pressure decreases. The fan turns off and the test ends after you respond to the prompt. Possible results include: Fail - Prompt Response Not Received, Warning - Exhaust Fan Not Acknowledged, or Pass.

Acceptance Test

The Acceptance tests are available when the Damper Test passes. You can skip these tests with the UI.

Outdoor Air Ventilation Test

The Outdoor Air Ventilation Test certifies compliance with NA7.5.1.2 Outdoor Air Acceptance (Form CEC-MECH-2A). This test disables the Economizer and DCV, which causes the damper to open to the fixed minimum position. You measure the OA flow and have 10 minutes to respond to the prompt. Possible results include: Fail - OA flow not measured or Pass.

Rooftop Unit Test

The Rooftop Unit Test evaluates the entire thermostat, Economizer, and RTU system while certifying compliance with NA7.5.2 Rooftop Acceptance (Form NRCA-MCH-03-A). This test disables the Economizer and DCV operation. You have 20 minutes to perform system tests and respond to a prompt on the controller. Possible results include: Fail - RTU prompt not acknowledged and Pass.

Economizer Test

The Economizer Test certifies compliance with NA7.5.4 Air Economizer Controls Acceptance (Form NRCA-MCH-05-A). This test disables the DCV and simulates the demand for cooling, free cooling availability, and supply air temperature to quickly open the damper to 100% (Steps 2a/2b on form). You must confirm the return air damper operates properly. Another simulation begins to verify integrated Economizer operation (Step 2c on the form). The Economizer disables and the damper closes to the minimum position (Step 3 on the form). Possible results include: Fail - OA damper not modulating, Fail - RA damper not modulating, Fail - No integrated Economizer operation, Fail - Prompt respond not received, and Pass.

DCV Test

The DCV Test certifies compliance with NA7.5.5 Demand Control Ventilation Systems Acceptance (Form CEC-MECH-6A). The Economizer operation disables and an IAQ sensor reading greater than the active setpoint is simulated. The test verifies that the damper opens from the minimum position (Step 1 on the form). After a one-minute delay, an IAQ sensor reading of 0 ppm simulates and the test system verifies that the damper closes to minimum position (Step 2 on the form). Possible results include: Fail - DCV not functioning or Pass.

FDD Test

The FDD Test certifies compliance with NA7.5.11 Fault Detection and Diagnostics (FDD) (Form NRCA-MCH-12-A). The system instructs you to disconnect the OA temperature sensor from the unit (Step 2 on the form). You must confirm a fault is reported. Then you are instructed to reconnect the OA Temperature sensor (Step 3 on the form) and confirm the faults are cleared. Possible results include: Fail - Faults not detected, Fail - Faults not cleared, and Pass.

Sequence of Operation

The RRS Economizer has software applications embedded in a custom hardware control system that provides you with the ability to bring outside air into a building and reduce the use of mechanical equipment. The RRS Economizer provides outside air cooling with the following components: outside air damper, supply air temperature sensor, outside air temperature sensor, and thermostat inputs (RTU or heat pump control).

The Advanced RRS Economizer model additionally provides you the ability to control an exhaust fan by a Variable Frequency Drive (VFD) or Energy Recovery Ventilator (ERV). The advanced model also offers controls for building pressure, outside airflow, outdoor air quality, and purge.

Concepts

Free Cooling Sequences

When the Free Cooling Selection variable is set to Auto (default), the Economizer selects which free cooling method to use based on which temperature and humidity sensors are present and reliable. See Table 7.

The order of free cooling selection is: Dual Enthalpy, Single Enthalpy, and Dry Bulb. You can manually select the free cooling type.

Table 7: Free Cooling Sensor Requirements

Free Cooling Method	Sensor Type			
	Outdoor Air Temperature (OAT)	Outdoor Air Humidity (OAH)	Return Air Temperature (RAT)	Return Air Humidity (RAH)
Dry Bulb	X			
Single Enthalpy	X	X		
Dual Enthalpy	X	X	X	X

Changeover Setpoint Determination

Table 8 describes when free cooling is available for dry bulb, single enthalpy, and dual enthalpy.

Table 8: Free Cooling Determination

Free Cooling Type	Condition	Description
Dry Bulb	Available	OAT < (Economizer OAT Enable Setpoint - 1°F)
	Unavailable	OAT > Economizer OAT Enable Setpoint
	Note: If the outside air dry bulb temperature value is unreliable, free cooling is not available. The free cooling dry bulb setpoint is adjustable between 40 and 80°F.	
Single Enthalpy	Available	OA Enthalpy < (Outside Air Enthalpy Setpoint - 1 Btu/lb) and OAT < (High Limit Shutoff - 1°F)
	Unavailable	OA Enthalpy > Outside Air Enthalpy Setpoint or OAT > High Limit Shutoff
	Note: The Free Cooling OA Enthalpy Setpoint is adjustable between 10 Btu/lb and 50 Btu/lb.	
Dual Enthalpy	Available	OA Enthalpy < (RA Enthalpy - 1 Btu/lb) and OAT < (High Limit Shutoff - 1°F)
	Unavailable	OA Enthalpy > RA Enthalpy or OAT > High Limit Shutoff

Outside Air Damper Sequences

When the control is in Occupied Mode and the FAN output is energized, the OA Damper position is based upon the largest position command determined by the controlling strategies. The control system positions the outside air damper based on:

- minimum damper position setpoint (default)
- low ambient minimum position reset
- outdoor air flow (advanced model only)
- demand ventilation
- purge
- free cooling modulation

Minimum Position

Minimum Position requires that other damper control strategies are inactive. While in this mode, the controller commands the Outdoor Air Damper to the Damper Minimum Position Setpoint parameter.

Low Ambient Minimum Position

The Low Ambient Economizer minimum position overrides all other minimum position functions.

When the control is in the occupied mode and the operational OAT is below the Low Ambient Economizer Setpoint, the Economizer is positioned to the Low Ambient Economizer minimum position. When the Operational OAT is equal to, or above, the Low Ambient Economizer Setpoint, the control exits the Low Ambient Economizer setpoint mode.

Outdoor Air Flow Monitoring

This control sequence is only available on the advanced model. You must have an Outdoor Air Flow Sensor installed and reading a reliable value to enable this control sequence.

When the Outdoor Air Flow Monitoring strategy is active, the Economizer modulates the Outdoor Air Damper between Minimum Position and 100% to maintain the Fresh Air Intake value for the Fresh Air Intake Setpoint +/- 40 cfm.

Demand Ventilation

If the demand ventilation is configured and the operational indoor CO₂ level is greater than the Demand Ventilation Setpoint +100 ppm, the current operating minimum position increases with a CO₂ level:

- between demand ventilation setpoint +101 ppm and +200 ppm, the operating minimum position increases 1% per minute
- greater than demand ventilation setpoint +200 ppm, the operating minimum position increases 2% per minute

When the CO₂ level drops to a value below the Demand Ventilation Setpoint, the current operating minimum position decreases at the same rate.

While in a demand ventilation mode, if the supply air temperature drops below 49°F, the Economizer outside air damper closes to the current operating minimum position until the supply air temperature rises above 49°F.

On the advanced model, if the Differential DCV Enable is On and the OAQ is greater than or equal to the IAQ by more than the Demand Ventilation Differential Setpoint, the outside air damper is commanded closed, which completely overrides all other minimum position functions.

Purge

This feature is only available on the advanced model. The Purge sequence enables when the Purge Input is True. The Outside Air Damper fully opens (100%), and mechanical cooling turns off during this sequence. The Economizer still opens the Outside Air Damper to 100% if the Occupied signal is False. If an exhaust fan is part of the configuration, the controller turns on the exhaust fan command.

Free Cooling Modulation

The Economizer controller modulates the Outdoor Air Damper between Minimum Position and 100% to maintain the Supply Air Temperature to the Supply Air Temperature Setpoint.

Mechanical Cooling

When the Y2 input is active while Free Cooling is enabled, the Economizer modulates the Outdoor Air Damper to 100% open and turns the Y1 Output On to enable Stage 1 of mechanical cooling on the Rooftop Unit (RTU). After 20 minutes, if the Y2 Input is still active, the Economizer turns on the Y2 Output and enables the second stage of mechanical cooling. Table 9 shows the command for each output and the modes of operation.

Table 9: Mechanical Cooling Determination

Modes	Inputs			Outputs		
	Y1	Y2	W1	Y1 Out	Y2 Out	Damper
Econ	1	0	0	Off	Off	Min -100%
Econ + Mech	1	1	0	On	Off ¹	100%
Mech	1	0	0	On	Off	Min
Mech	1	1	0	On	On	Min
Heating	0	0	1	Off	Off	Min

1. This turns on if the Y2 Input remains on for over 20 minutes.

Exhaust Fan Control

Note: The Direct Exhaust Fan Control and the ERV control share the same output when they are configured. The Ruskin ERV controller controls the exhaust fan when the ERV is enabled and present.

The Economizer has three power exhaust fan control options:

1. None (default)
2. Non-Modulating
3. Modulating (building pressure control)

Operation

Non-Modulating

When the Outdoor Air Damper command rises above the Exhaust Fan ON Setpoint, the exhaust fan commands ON. When the Outdoor Air Damper output drops below the Exhaust Fan OFF Setpoint, the exhaust fan commands OFF.

Modulating (Building Pressure Control)

This operation is only available in the Advanced Economizer model.

When the building pressure rises above the Building Pressure Setpoint, the output increases to the Exhaust Fan VFD Percent Command output. When this output rises above 2%, the Exhaust Fan Command turns On.

When the building static pressure decreases below the Building Pressure Setpoint, the output decreases to the Exhaust Fan VFD Percent Command output. When this output decreases to 2% or less, the Exhaust Fan Command turns Off.

The rate of change for the analog output is determined by the deviation from the setpoint and the length of time away from the setpoint.

Energy Recovery Ventilator

When the RRS Economizer is configured with the Energy Recovery Ventilator feature, it provides an output to energize the ERV. The ERV pivot function is enabled by the ERV output (BO) connected to the controller. The binary output energizes when the damper position is greater than 50% (adjustable) with a 5% differential.

Heat Pump

When the RRS Economizer is connected to a heat pump, configure the Economizer Controller Thermostat Type parameter to O if the O/B output on the thermostat is energized during cooling mode or to B if the O/B output on the thermostat is energized during heating mode. Table 10 and Table 11 detail the output commands for each type of configuration.

Table 10: Heat Pump Thermostat — Configured to Energize O/B in Cooling Mode

Modes	Inputs			Outputs		
	Y1	Y2	O	Y1 Out	Y2 Out	Damper
Econ	1	0	1	Off	Off	Min -100%
Econ + Mech	1	1	1	On	Off	100%
Mech	1	0	1	On	Off	Min
Mech	1	1	1	On	On	Min
Heating	1	0	0	On	On	Min
Heating	1	1	0	On	On	Min

Table 11: Heat Pump Thermostat — Configured to Energize O/B in Heating Mode

Modes	Inputs			Outputs		
	Y1	Y2	B	Y1 Out	Y2 Out	Damper
Econ	1	0	0	Off	Off	Min -100%
Econ + Mech	1	1	0	On	Off	100%
Mech	1	0	0	On	Off	Min
Mech	1	1	0	On	On	Min
Heating	1	0	1	On	Off	Min
Heating	1	1	1	On	On	Min

Excessive Supply Air Temperature (SAT) Control

The excessive SAT control strategy prevents damage to compressor elements due to extremes of the SAT. If the SAT falls below the Excessive SAT (Cooling) setpoint, the control terminates a cooling stage. The control waits for the user-defined SAT Monitor Time, if the SAT is still below the Excessive SAT (Cooling) setpoint, it terminates another stage of cooling.

The control sequence returns to the normal state when the SAT is greater than the Excessive SAT (Cooling) Setpoint for the user-defined Excessive SAT Min OFF Time.

Two-Speed Supply Fan

Table 12 describes the two-speed supply fan operation.

Table 12: Two-Speed Fan Operation

Input Signals	Derived Fan Speed
Unoccupied/Not OCC	Off
Occupied/OCC	Low
Y1	Low
Y2	High
W	High

In addition, the Economizer UI shows setpoints to control the On/Off operation of an Exhaust Fan when present and configured for Non-Modulating mode. The Economizer uses the BO output to turn the exhaust fan on and off depending on your configuration.

The Two-Speed Fan additional setpoints are:

Economizer EF On Setpoint—Indicates the Economizer damper position at which the exhaust fan turns on when Fan Type is set to single speed or when the Supply Fan speed is High and Fan Type is two-speed.

Economizer EF Off Setpoint—Indicates the Economizer damper position at which the exhaust fan turns off. This input value is used when Fan Type is set to single speed or when the Supply Fan speed is High and Fan Type is two-speed.

Economizer SF Low Speed EF Off Setpoint—Indicates the Economizer damper position at which the exhaust fan turns off. This input is conditioned when Fan Type is set to two-speed and when the Supply Fan speed is Low.

Economizer SF Low Speed EF On Setpoint—Indicates the position for the Economizer damper at which the exhaust fan turns on. This input is conditioned when the Fan Type is set to two-speed and when the Supply Fan is Low.

Locate these additional two-speed fan setpoints within the Commission sub-menu, after you enable two-speed fan.

Low Voltage Response

When the Economizer controller detects the 24 VAC signal is less than 19.2 VAC, the controller does not allow any additional relay outputs commanded ON and initiates an alarm.

When the Economizer controller detects the 24 VAC signal is less than 16 VAC, the controller de-energizes all relay outputs and initiates an alarm for the condition.

Alarms

Table 13: Alarms

Alarm Text	Description
Outputs Disabled Due to Low Input V	When a blackout condition is detected, all outputs deactivate.
Outputs Limited Due to Brownout Input V	When a brownout condition is detected, all outputs are held at the current state.
Building Pressure Sensor Failure	Identifies an unreliable or disconnected building pressure sensor.
Outdoor Air Temperature Sensor Failure	Identifies an unreliable or disconnected outdoor air temperature sensor.
Return Air Temperature Sensor Failure	Identifies an unreliable or disconnected return air temperature. The control returns to the fixed dry bulb.
Supply Air Temperature Sensor Failure	Identifies an unreliable or disconnected supply air temperature sensor.
Econ Controller Calibration Error	Detects that the damper position calibration is not present. The Economizer disables.
Return Air Humidity Sensor Failure	Identifies an unreliable or disconnected return air humidity sensor. The control returns to the fixed enthalpy + dry bulb.
Outdoor Air Humidity Sensor Failure	Identifies an unreliable or disconnected outdoor air humidity sensor. The control returns to the dry bulb.
Indoor Air Quality Sensor Failure	Identifies an unreliable or disconnected indoor CO ₂ sensor. DCV disables.
Outdoor Air Quality Sensor Failure	Indicates an unreliable or disconnected outdoor CO ₂ sensor. The differential DVCV disabled.
Low Outdoor Air Temp Cooling Cutout	Indicates Low Temperature Limit and disables economizing and mechanical cooling.
Economizer Letting In Excess Outdoor Air	Indicates the damper is stuck open or an actuator/sensor failure.
Unit has Received a Purge Request	Indicates a Purge signal is present.
Excessive Supply Air Temp Cooling	Indicates the supply air temperature is less than the Excessive SAT Cooling Setpoint.

Title 24 Alarms

Table 14: Alarms

Alarm Text	Description
Fresh Air Intake Sensor Failure	Identifies an unreliable or disconnected outdoor air flow sensor.
Air Temperature Sensor Failure	Indicates one or more air temperature sensors are unreliable or disconnected.
Econ Economizing When It Should Not	Indicates the damper is stuck open or an actuator/sensor failure.
Econ Not Economizing When It Should	Indicates the damper is stuck at minimum position or an actuator/sensor failure.
Economizer Damper Not Modulating	Indicates the damper is not responding to commands or an actuator/sensor failure.
Economizer Letting In Excess Outdoor Air	Indicates the damper is stuck open or an actuator/sensor failure.