



INSTALLATION INSTRUCTIONS

ECOCSLM1830- SE/ECOSLU180- SE Series Convertible Economizer for York Sunline 15-25

Before Starting Installation

Ton Units



PARTS INCLUDED	QTY.
Male Wire Connectors	2

Only qualified HVAC service personnel should install, troubleshoot, repair or service HVAC and related HVAC equipment.

Installation Instructions

1. Turn power off to unit being serviced or worked on.
2. Remove horizontal duct panels and filter access panel, saving unit screws for securing economizer hoods. Also, remove filters from unit. This will make economizer easier to install. Filters will be put back at conclusion of economizer installation.
3. Remove the center support post as shown in the drawing ILL.
4. Slide economizer into unit as shown making sure to lift the front bottom flange into place. Position should be flush with panel. Prepunched holes will align with the two screw holes removed from previous step. Use these screws to secure economizer.

ILL. 1

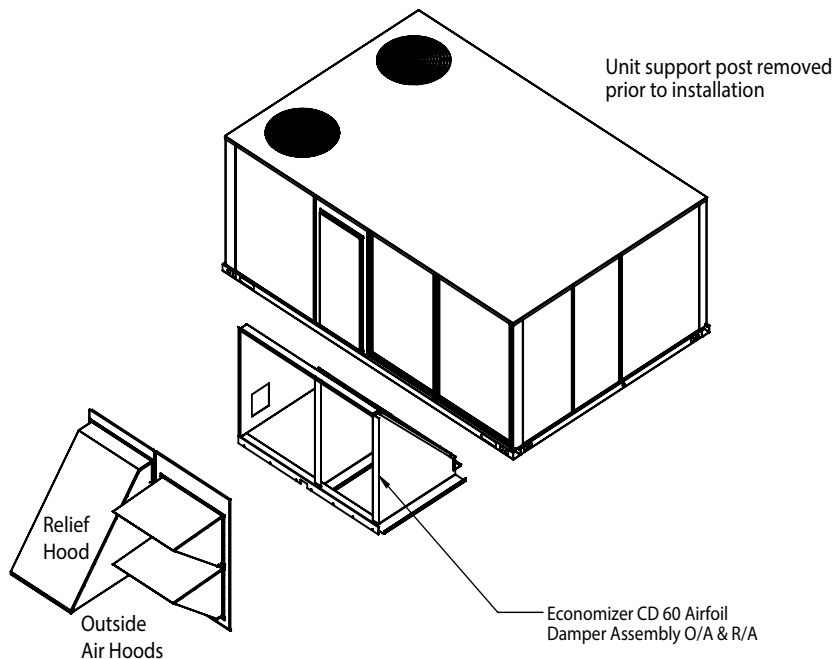

5. Remove RAT sensor and bracket. ILL. 2 (if required)
6. Break off RAT sensor from part of bracket. ILL. 2 (if required)
7. Secure RAT sensor with screws provided with the economizer on the R/A compartment of the economizer as shown below. (if required)
8. Locate the harness in the return compartment with brown wire 845 and red wire 846. Connect this harness into the "24V-IN" connections on the economizer controller. Locate the harness in the return compartment with the black wire 840, white wire 841, and the red wire 842. Connect this harness to the "SA BUS" connections on the economizer controller. Refer to the unit wiring diagram.
9. With screws from the duct panel removed previously, install hoods provided with the economizer. The outside air hood with metal filter is mounted on the right side.
10. For horizontal return duct designed systems, relief hood needs to be positioned on return duct.
11. Refer to economizer setting instructions below to properly set economizer position and/ or DCV.

ILL. 2

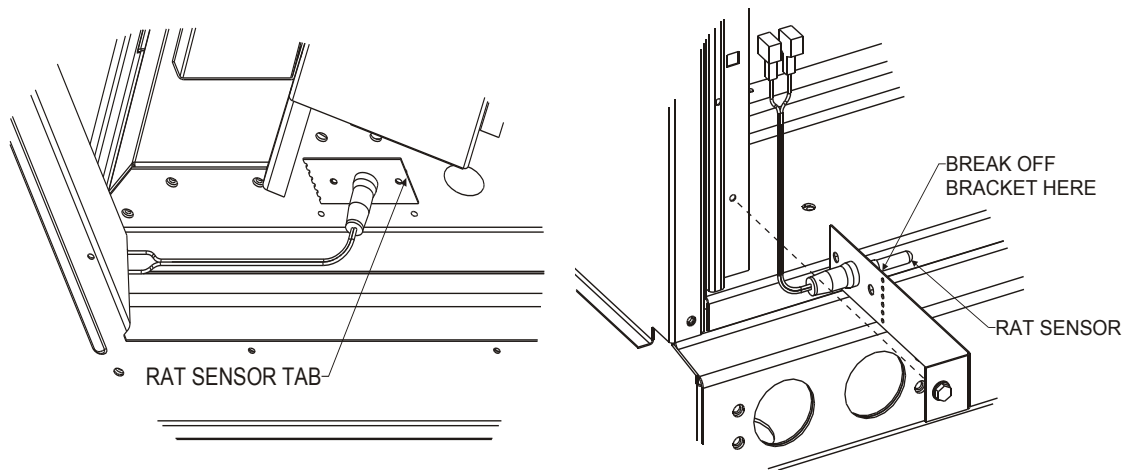

ILL. 3

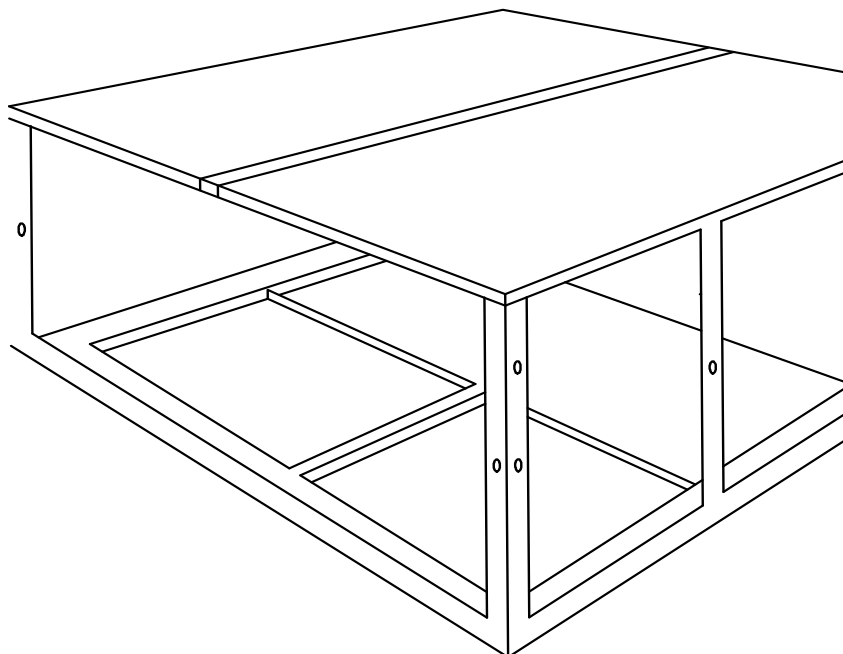

ILL. 4 Control Wiring Diagram

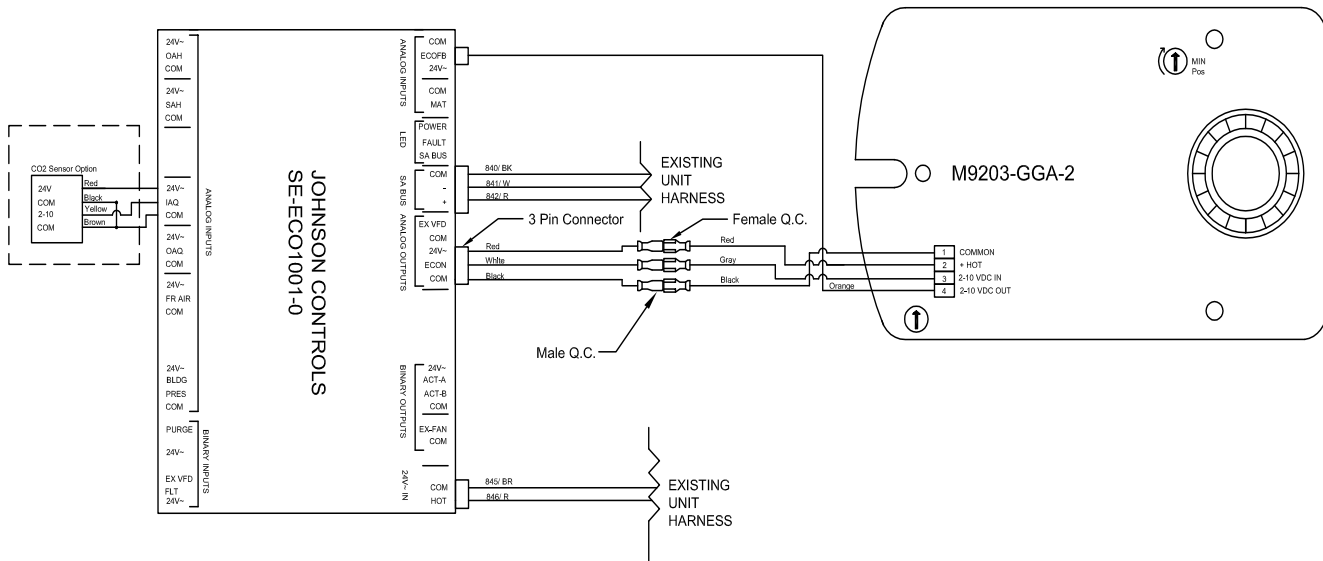

NOTES:

⚠ Unit wiring shown is used as reference only. Check unit wiring for actual unit wiring.

Ensure actuator mode setting is set to 2-10VDC. (Whether this is CW or CCW depends on the model, ensure this is opposite to the spring return, may require flipping of the actuator).

OCCUPIED SETTING CHANGE TO EXTERNAL (UCD OCC TERMINAL) UNLESS SCHEDULE HAS BEEN PROGRAMMED USING COM BOARD ACCESSORY AND LAPTOP.

Details <enter>
Zone <enter>
Indoor <enter>
OccMode <enter>

Change from schedule to external by moving joystick to the right, select external <enter>
Ensure the OCC terminal on the UCB has a 24VAC signal present.

SET MINIMUM POSITION

Details <enter>
Control <enter>
Econ <enter>
Setup <enter>
Econ-En <enter>

Ensure setting is YES (change to YES if currently set to NO <enter>)
Cancel out
Scroll Down to Econ-MinPos <enter>
Set to desired opening % <enter>

Escape back to Main Menu (Allow up to five (5) minutes for changes to take effect).

AIR ECONOMIZER CONTROLS ACCEPTANCE

CEC-NRCA-MCH-05-A (Revised 06/14)

CALIFORNIA ENERGY COMMISSION



CERTIFICATE OF ACCEPTANCE		NRCA-MCH-05-A
Air Economizer Controls Acceptance		(Page 1 of 3)
Project Name:	Enforcement Agency:	Permit Number:
Project Address:	City:	Zip Code:
System Name or Identification/Tag:	System Location or Area Served:	

Note: Submit one Certificate of Acceptance for each system that must demonstrate compliance.	Enforcement Agency Use: Checked by/Date
--	---

A. Construction Inspection
<p>1. Supporting documentation needed to perform test includes:</p> <ol style="list-style-type: none"> 2013 Building Energy Efficiency Standards Nonresidential Compliance Manual (NA7.5.4 Air Economizer Controls Acceptance At - Glance). 2013 Building Energy Efficiency Standards.
<p>2. Instrumentation to perform test includes:</p> <ol style="list-style-type: none"> Hand-held temperature probe Calibration Date: _____ (must be within last year) Device capable of calculating enthalpy Calibration Date: _____ (must be within last year) 1.2 k Ohm Resistor (when specified by the manufacturer)
<p>3. Installation: (all of the following boxes should be checked)</p> <p>Economizer high limit shutoff control complies with Table 140.4-B found in the 2013 Building Energy Efficiency Standards Section 140.4(e)3.</p> <p>Economizer reliability features are present per 2013 Building Energy Efficiency Standards Section 140.4(e)4:</p> <ol style="list-style-type: none"> 5-year manufacturer warranty of economizer assembly Provide a product specification sheet proving capability of at least 60,000 actuations Provide a product specification sheet proving compliance with AMCA Standard 500 damper leakage at 10 cfm/sf at 1.0 in w.g. A product specification sheet showing the manufacturer's results after following the testing procedures of AMCA Standard 500 or AMCA certification by a third party under AMCA Publication 511 can be used to satisfy this requirement (Class 1A, 1, and 2 are acceptable). If the high limit setpoint is fixed dry-bulb or fixed enthalpy + fixed dry-bulb then the control shall have an adjustable setpoint Outdoor air, return air, mixed air, and supply air sensors shall be calibrated as follows: <ol style="list-style-type: none"> Drybulb and wetbulb temperatures accurate to $\pm 2^{\circ}\text{F}$ over the range of 40°F to 80°F Enthalpy accurate to ± 3 Btu/lb over the range of 20 Btu/lb to 36 Btu/lb Relative humidity (RH) accurate to $\pm 5\%$ over the range of 20% to 80% RH Check that the sensor performance curve(s) is provided by the factory and sensor output values measured during sensor calibration are plotted on the performance curve(s) Sensors used for high limit control shall be located to prevent false readings, including but not limited to being properly shielded from direct sunlight. <p>Unitary systems with an economizer have control systems, including two-stage or electronic thermostats, that cycle compressors off when economizers can provide partial cooling</p> <p>System has return fan speed control, relief dampers, or dedicated relief fans to prevent building over pressurization in full economizer mode.</p> <p>For systems with DDC controls, sensor used for economizer lockout has been factory or field calibrated.</p> <p>For systems with non-DDC controls, manufacturer's startup and testing procedures have been applied.</p>

AIR ECONOMIZER CONTROLS ACCEPTANCE



CERTIFICATE OF ACCEPTANCE		NRCA-MCH-05-A
Air Economizer Controls Acceptance		(Page 2 of 3)
Project Name:	Enforcement Agency:	Permit Number:
Project Address:	City:	Zip Code:
System Name or Identification/Tag:	System Location or Area Served:	

B. Functional Testing	Results
Step 1: Disable demand control ventilation systems (if applicable)	
Step 2: Enable the economizer and simulate a cooling demand large enough to drive the economizer fully open. Verify the following:	
a. Economizer damper modulates 100% open.	Y / N
b. Return air damper modulates 100% closed.	Y / N
c. For systems that meet the criteria of 2013 Building Energy Efficiency Standards Section 140.4(e)1, verify that the economizer remains 100% open with the use of mechanical cooling. This occurs when the cooling demand can no longer be met by the economizer alone.	Y / N
d. All applicable fans and dampers operate as intended to maintain building pressure.	Y / N
e. The unit heating is disabled (if applicable).	Y / N / NA
Step 3: Disable the economizer and simulate a cooling demand. Verify the following:	
a. Economizer damper closes to its minimum position.	Y / N
b. All applicable fans and dampers operate as intended to maintain building pressure.	Y / N
c. The unit heating is disabled (if applicable).	Y / N / NA
Step 4: If the unit is equipped with heating, simulate a heating demand and enable the economizer. Verify the following:	
a. Economizer damper closes to its minimum position.	Y / N / NA
b. Return air damper opens.	Y / N / NA
Step 5: Turn off the unit and verify the following:	
a. Economizer damper closes completely.	Y / N
Step 6: System returned to initial operating conditions	Y / N

C. Testing Results	PASS	FAIL
Step 2: Simulate cooling load and enable the economizer (all answers are Y).		
Step 3: Simulate cooling load and disable the economizer (all answers are Y).		
Step 4: Simulate heating demand and enable the economizer (all answers are Y).		
Step 5: Turn off the unit (all answers are Y).		

D. Evaluation :
PASS: All Construction Inspection responses are complete and all Testing Results responses are "Pass"

Notes:

AIR ECONOMIZER CONTROLS ACCEPTANCE

CEC-NRCA-MCH-05-A (Revised 06/14)

CALIFORNIA ENERGY COMMISSION



CERTIFICATE OF ACCEPTANCE		NRCA-MCH-05-A
Air Economizer Controls Acceptance		(Page 3 of 3)
Project Name:	Enforcement Agency:	Permit Number:
Project Address:	City:	Zip Code:
System Name or Identification/Tag:	System Location or Area Served:	

DOCUMENTATION AUTHOR'S DECLARATION STATEMENT

1. I certify that this Certificate of Acceptance documentation is accurate and complete.

Documentation Author Name:	Documentation Author Signature:
Documentation Author Company Name:	Date Signed:
Address:	ATT Certification Identification (If applicable):
City/State/Zip:	Phone:

FIELD TECHNICIAN'S DECLARATION STATEMENT

I certify the following under penalty of perjury, under the laws of the State of California:

- The information provided on this Certificate of Acceptance is true and correct.
- I am the person who performed the acceptance verification reported on this Certificate of Acceptance (Field Technician).
- The construction or installation identified on this Certificate of Acceptance complies with the applicable acceptance requirements indicated in the plans and specifications approved by the enforcement agency, and conforms to the applicable acceptance requirements and procedures specified in Reference Nonresidential Appendix NA7.
- I have confirmed that the Certificate(s) of Installation for the construction or installation identified on this Certificate of Acceptance has been completed and signed by the responsible builder/installer and has been posted or made available with the building permit(s) issued for the building.

Field Technician Name:	Field Technician Signature:	
Field Technician Company Name:	Position with Company (Title):	
Address:	ATT Certification Identification (if applicable):	
City/State/Zip:	Phone:	Date Signed:

RESPONSIBLE PERSON'S DECLARATION STATEMENT

I certify the following under penalty of perjury, under the laws of the State of California:

- I am the Field Technician, or the Field Technician is acting on my behalf as my employee or my agent and I have reviewed the information provided on this Certificate of Acceptance.
- I am eligible under Division 3 of the Business and Professions Code in the applicable classification to accept responsibility for the system design, construction or installation of features, materials, components, or manufactured devices for the scope of work identified on this Certificate of Acceptance and attest to the declarations in this statement (responsible acceptance person).
- The information provided on this Certificate of Acceptance substantiates that the construction or installation identified on this Certificate of Acceptance complies with the acceptance requirements indicated in the plans and specifications approved by the enforcement agency, and conforms to the applicable acceptance requirements and procedures specified in Reference Nonresidential Appendix NA7.
- I have confirmed that the Certificate(s) of Installation for the construction or installation identified on this Certificate of Acceptance has been completed and is posted or made available with the building permit(s) issued for the building.
- I will ensure that a completed, signed copy of this Certificate of Acceptance shall be posted, or made available with the building permit(s) issued for the building, and made available to the enforcement agency for all applicable inspections. I understand that a signed copy of this Certificate of Acceptance is required to be included with the documentation the builder provides to the building owner at occupancy.

Responsible Acceptance Person Name:	Responsible Acceptance Person Signature:	
Responsible Acceptance Person Company Name:	Position with Company (Title):	
Address:	CSLB License:	
City/State/Zip:	Phone:	Date Signed: