

**FEATURES**

- Direct coupled style actuator standard.
- **CA Title 24 Compliant**
- Stainless steel damper side seals.
- **AMCA certified CD-60 Airfoil dampers blades.**
- **Meets leakage rate as required by ASHRAE 90.1.**
- External linkage system.
- Mechanically secured outside air intake filter.
- Capable of introducing up to 100% outdoor air.
- 16" X 14" X 7/8" (EXACT) Metal Filter included.

**FEATURES (When Ordered With Control Options)**

- Controls are FDD Compliant
- Fully modulating damper controls with enthalpy, dry bulb and differential temperature sensor options.
- Selectable economizer changeover temperature set point.
- Requires part number 6210-0046 for Dual Enthalpy.
- Logic module includes DCV for CO2 applications.  
Wall or duct mounted CO2 sensor provided as option:  
CO2WM - Wall Mount  
CO2DM - Duct Mount

**LEED ECONOMIZER OPTION**

- ProVent P/N: FLOWECLXS
- Outside air measurement for dilution utilizing thermal dispersion technology and ASHRAE 62.1 compliant. Provides LEED credit by supplying feedback on ventilation system performance ensuring that the ventilation system maintains design requirements.
- Factory installed onto economizer standard.
- Provides analog outputs for BMS, visual or audible alert, and generates an alarm when conditions vary by 10% or more of set point.

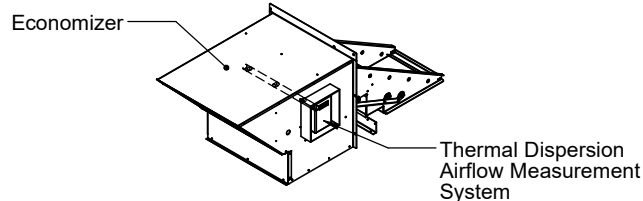

**VERTICAL ECONOMIZER FOR YORK UNITS**

PG3E, PC3E, PCG4A, PCE4A 24-42  
PCG6A, PCE6A, PHE4/6A, PHG4/6A 24-30

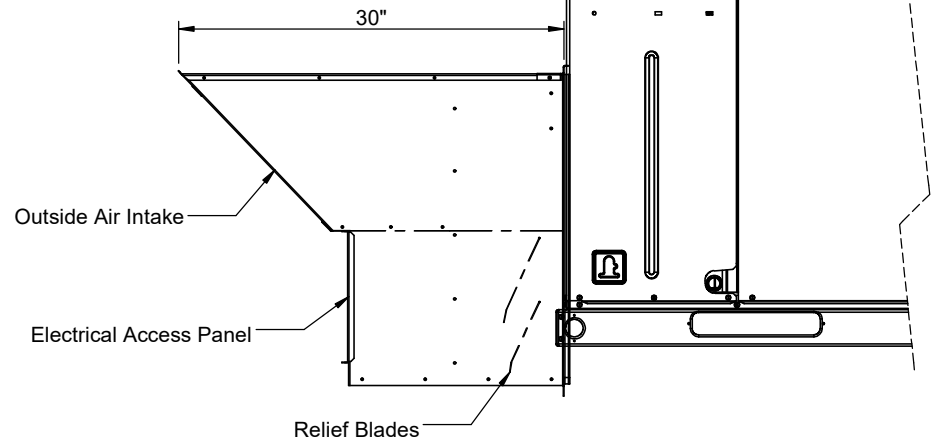
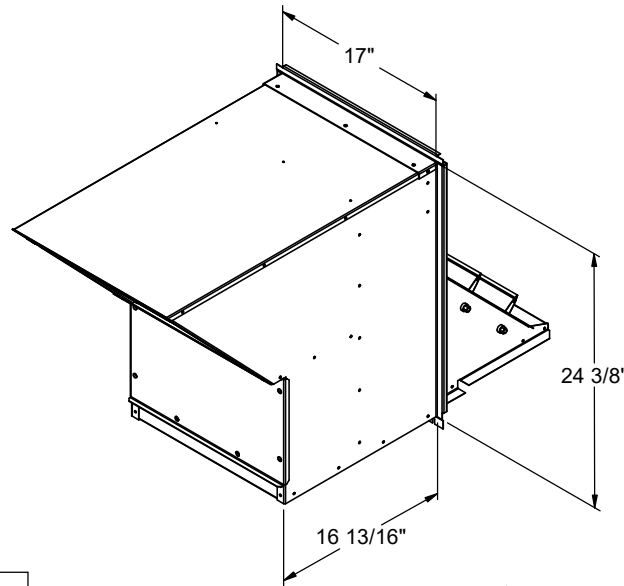

Ruskin Company Model CD-60 is AMCA Certified

ProVent P/N

Wt.

ECODLXSAC  
(Actuator Only, 2-10 VDC)

ECODLXSDB  
(Fully Modulating Dry Bulb)

ECODLXSEN  
(Fully Modulating Enthalpy)

50 Lb.

**Note: For factory installed LEED economizer option, part number FLOWECLXS must be added.**



3847 WABASH DRIVE  
MIRA LOMA, CA 91752

PHONE (951) 685-1101  
FAX (619) 872-9799

SUBMITTED TO: \_\_\_\_\_  
COMPANY: \_\_\_\_\_  
JOB NAME: \_\_\_\_\_  
EQUIPMENT: \_\_\_\_\_  
NOTES: \_\_\_\_\_

FORM NO:

ECO-500

DATE:

2/10/2025

PART NUMBER:

ECODLXS Series

REV:

7

DRAWN BY:

CNG