

FEATURES

- CA Title 24 Compliant.
- Direct coupled style actuator standard.
- Stainless steel damper side seals.
- AMCA certified CD-60 Airfoil dampers blades.
- Meets leakage rate as required by ASHRAE 90.1.
- External linkage system.
- Mechanically secured outside air intake filter.
- Metal Filter included:
 - PRS - 25-1/2" x 11" x 7/8" (exact).
 - PRL - 33-1/2" x 10-1/2" x 7/8" (exact).

FEATURES (When Ordered With Control Options)

- Fully modulating damper controls with enthalpy, dry bulb and differential temperature sensor options.
- Selectable economizer changeover temperature set point.
- Requires part number 2ECO402 for Dual Enthalpy.
- CO2 controller standard.
 - Wall or duct mounted CO2 sensor provided as option:
 - CO2WM - Wall Mount
 - CO2DM - Duct Mount

DOWNFLOW ECONOMIZER WITH BAROMETRIC RELIEF FOR YORK UNITS WITH HINGED FILTER ACCESS:

ZX04-14, ZY04-12, ZQ04-06, XY04-09, XX08-12, XQ04-06, ZXA7, XXA7, XYA7, ZYA7, ZL04-14

York Unit	ProVent P/N	"A"	"B"	"C"	"D"	Weight
ZX 04-07 ZY 04-06 ZQ 04-06 XY 04-06 XQ 04-06 ZL 04-06 ZX, XXA7	ECODPRSDBH (Fully Modulating Dry Bulb)	17-3/16"	18-3/8"	33-1/4"	17-3/8"	81 Lbs.
ZL 08-14 ZX 08-14 ZY 07-12 XX 08-12 XY 07-09 XY, ZYA7	ECODPRSENH (Fully Modulating Enthalpy)					
	ECODPRLDBH (Fully Modulating Dry Bulb)	19-3/4"	23-7/16"	40-3/4"	22"	94 Lbs.
	ECODPRLNHH (Fully Modulating Enthalpy)					

Core Large Cabinet Shown

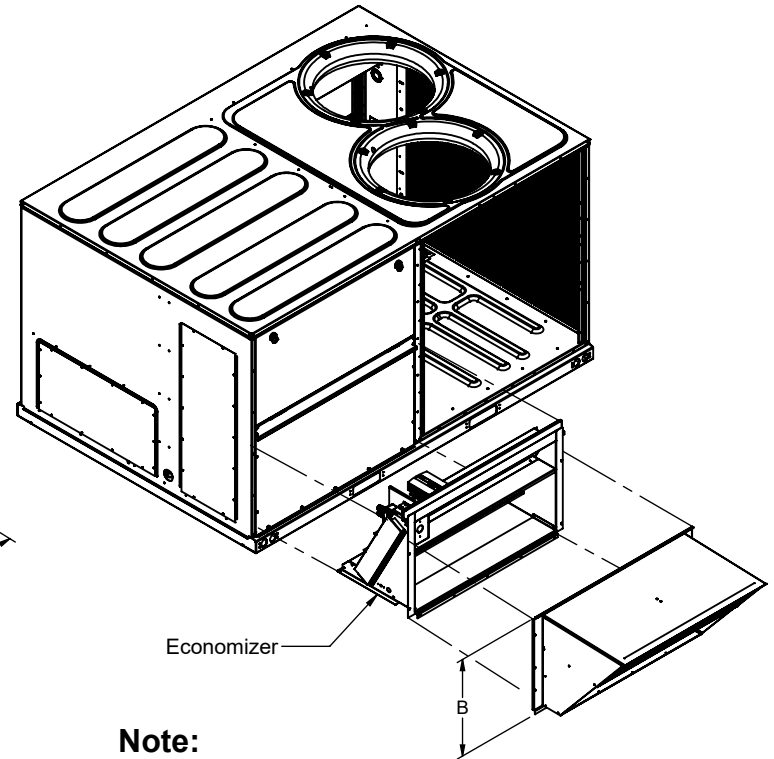

Note:
Works on RTU's with Hinged Filter Access Panels



Only Ruskin Company Model CD-60 is AMCA Certified

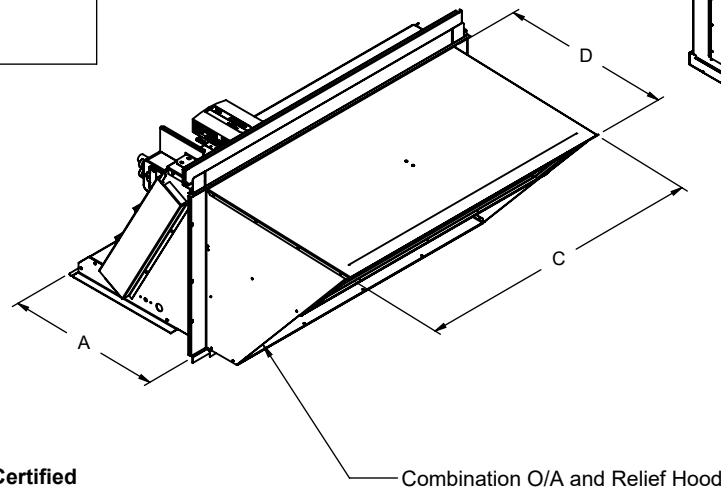

Combination O/A and Relief Hood



3847 WABASH DRIVE
MIRA LOMA, CA 91725

PHONE (951) 685-1101
FAX (619) 872-9799

SUBMITTED TO: _____
COMPANY: _____
JOB NAME: _____
EQUIPMENT: _____
NOTES: _____

FORM NO:

DATE:
1/24/2023

PART NUMBER:

ECODPR Series

REV:
M

DRAWN BY:
CNG