

FEATURES

- CA Title 24 Compliant.
- Direct coupled style actuator standard.
- Stainless steel damper side seals.
- **AMCA certified CD-60 Airfoil dampers blades.**
- **Meets leakage rate as required by ASHRAE 90.1.**
- External linkage system.
- Mechanically secured outside air intake filter.
- Capable of introducing up to 100% outdoor air.
- Relief hood provided for horizontal duct mount.
- Metal Filter 19" x 16" x 1" included.

FEATURES (When Ordered With Control Options)

- Fully modulating damper controls with enthalpy, dry bulb and differential temperature sensor options.
- Selectable economizer changeover temperature set point.
- CO2 compatible with DCV.

Wall or duct mounted CO2 sensor provided as option:

- CO2WM - Wall Mount
- CO2DM - Duct Mount



HORIZONTAL ECONOMIZER WITH BAROMETRIC RELIEF FOR YORK UNITS

PG3E, PC3E, PCG4A, PCE4A 24-42
PCG6A, PCE6A, PHE4/6A, PHG4/6A 24-30

ProVent P/N	Wt.
ECOHLXSAC1 (Actuator Only, 2-10 VDC)	53 Lb.
ECOHLXSDB1 (Fully Modulating Dry Bulb)	
ECOHLXSEN1 (Fully Modulating Enthalpy)	
Note: For factory installed LEED economizer option, part number FLOWECLXS must be added.	

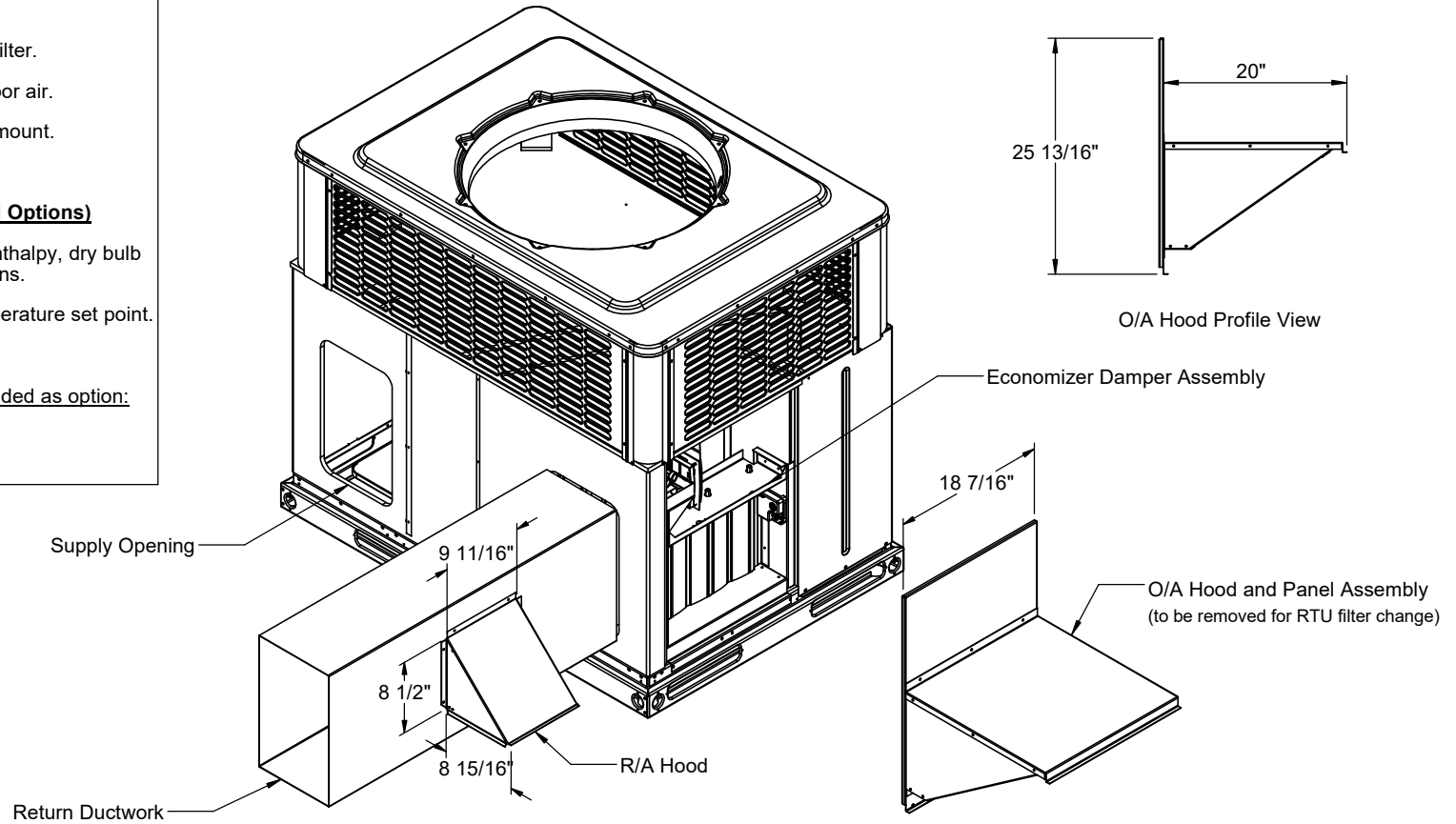

3847 WABASH DRIVE
MIRA LOMA, CA 91752

PHONE (951) 685-1101
FAX (619) 872-9799

SUBMITTED TO: _____
COMPANY: _____
JOB NAME: _____
EQUIPMENT: _____
NOTES: _____

FORM NO:

ECO-265

DATE:

3/11/2025

PART NUMBER:

ECOHLXS-1 Series

REV:

1

DRAWN BY:

CNG