

FEATURES:

- CA Title 24 Compliant.
- Factory assembled.
- Galvanized steel construction.
- AMCA certified CD-60 Airfoil damper blades.
- Meets leakage as required by ASHRAE 90.1
- Fully insulated.
- Direct coupled actuator.
- Controls package:
 - Includes dry bulb or enthalpy fully modulating controls. w/relay signal switch.
 - Specific control type: Add the two digits below to the Part Number:
 - DB** For dry bulb control.
 - EN** For enthalpy control.

DAMPER MIXING BOXES FOR ADP AV SERIES AIR HANDLERS

UNIT SIZE	PART NUMBER	CONTROL TYPE	A	B	C	EST. WT
AV240	MB-ADP-AV24AC-**	ACTUATOR ONLY	20"	16-1/2"	12"	71 LBS.
	MB-ADP-AV24DB-**	DRY BULB				
	MB-ADP-AV24EN-**	ENTHALPY				
AV360 AV480	MB-ADP-AV34AC-**	ACTUATOR ONLY	24"	18"	14"	86 LBS.
	MB-ADP-AV34DB-**	DRY BULB				
	MB-ADP-AV34EN-**	ENTHALPY				
AV600	MB-ADP-AV60AC-**	ACTUATOR ONLY	24"	20"	16"	92 LBS.
	MB-ADP-AV60DB-**	DRY BULB				
	MB-ADP-AV60EN-**	ENTHALPY				

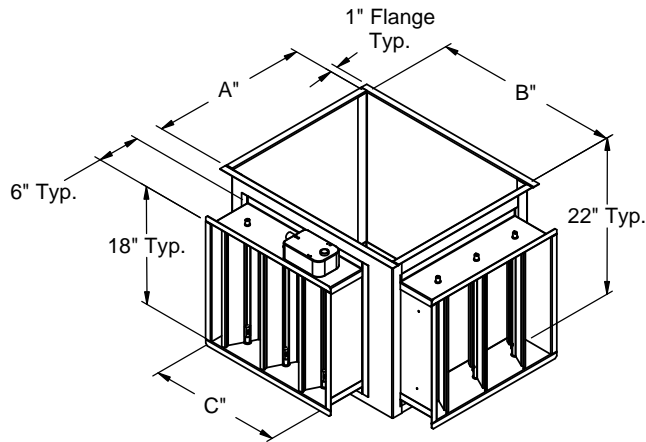
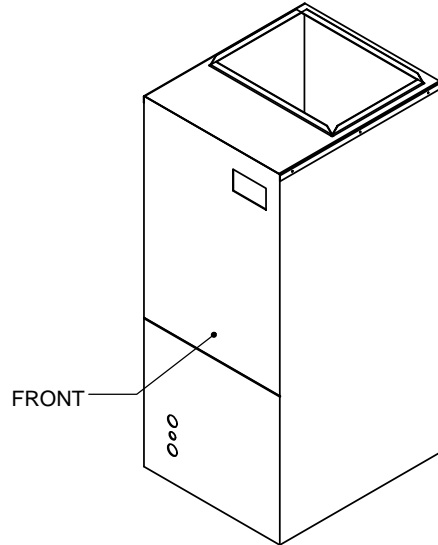

Example Shown
P/N: MB-ADP-AV60**-FA

Damper Locations

A, B, F, D, or E.
First position as Return.
(Added to end of part #)

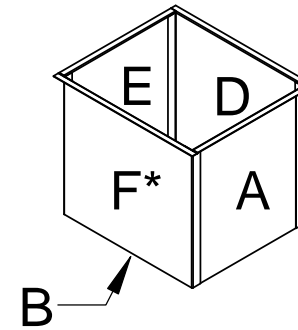

* F Position represents front of Mixing Box which will always match to front of Air Handler.



3847 WABASH DR.
MIRA LOMA, CA 91725

PHONE (951) 685-1101
FAX (619) 872-9799

SUBMITTED TO: _____
COMPANY: _____
JOB NAME: _____
EQUIPMENT: _____
NOTES: _____

FORM NO:
-

PART NUMBER:
MB-ADP-AV SERIES

DATE:
3/2/2016

REV:
1

DRAWN BY:
CNG