

FEATURES:

- CA Title 24 Compliant.
- Factory assembled.
- Galvanized steel construction.
- AMCA certified CD-60 Airfoil damper blades.
- Meets leakage as required by ASHRAE 90.1
- Fully insulated.
- Direct coupled actuator.
- Controls package:
 - Includes dry bulb or enthalpy fully modulating controls. w/relay signal switch.
 - Specific control type: Add the two digits below to the Part Number:
 - DB** For dry bulb control.
 - EN** For enthalpy control.

DAMPER MIXING BOXES FOR ADP AX SERIES AIR HANDLERS

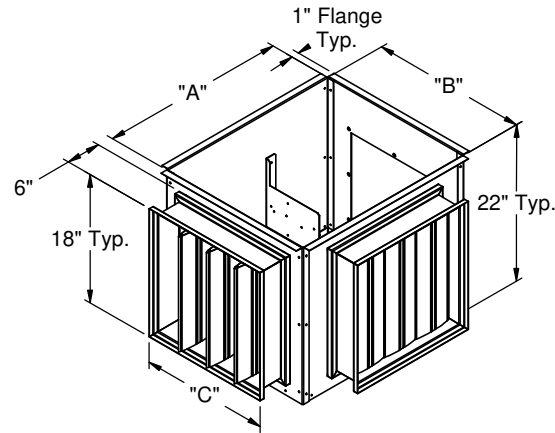
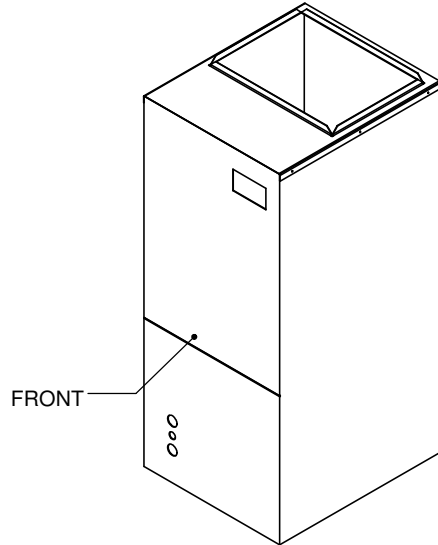

Example Shown
P/N: MB-ADP-AX3060**-FA

UNIT SIZE	PART NUMBER	CONTROL TYPE	A	B	C	EST. WT
AX240 AX361	MB-ADP-AX2436AC**-**	ACTUATOR ONLY	20"	16-1/2"	14"	79 LBS.
	MB-ADP-AX2436DB**-**	DRY BULB				
	MB-ADP-AX2436EN**-**	ENTHALPY				
AX241	MB-ADP-AX241AC**-**	ACTUATOR ONLY	22"	15"	11"	66 LBS.
	MB-ADP-AX241DB**-**	DRY BULB				
	MB-ADP-AX241EN**-**	ENTHALPY				
AX300, AX360 AX420, AX480 AX481, AX600	MB-ADP-AX3060AC**-**	ACTUATOR ONLY	24"	19-7/8"	18"	75 LBS.
	MB-ADP-AX3060DB**-**	DRY BULB				
	MB-ADP-AX3060EN**-**	ENTHALPY				

Damper Locations

A, B, F, D, or E.
First position as Return.
(Added to end of part #)

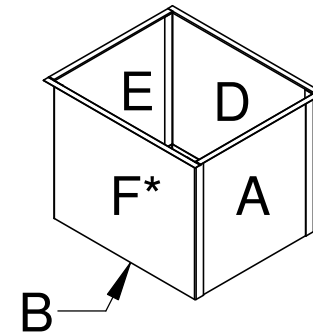

* F Position represents front of Mixing Box which will always match to front of Air Handler.



3847 WABASH DR.
MIRA LOMA, CA 91752

PHONE (951) 685-1101
FAX (619) 872-9799

SUBMITTED TO: _____
COMPANY: _____
JOB NAME: _____
EQUIPMENT: _____
NOTES: _____

FORM NO:
-

PART NUMBER:
MB-ADP-AX SERIES

DATE:
8/3/2022

REV:
1

DRAWN BY:
JG