

**FEATURES:**

- CA Title 24 Compliant.
- Factory assembled.
- Galvanized steel construction.
- AMCA certified CD-60 Airfoil damper blades.
- Meets leakage as required by ASHRAE 90.1
- Fully insulated.
- Direct coupled actuator.
- Controls package:
  - Includes dry bulb or enthalpy fully modulating controls. w/relay signal switch.
  - Specific control type: Add the two digits below to the Part Number:
    - DB** For dry bulb control.
    - EN** For enthalpy control.

**DAMPER MIXING BOXES FOR AVC, AVV, AE, JHET, JHVT SERIES AIR HANDLERS**

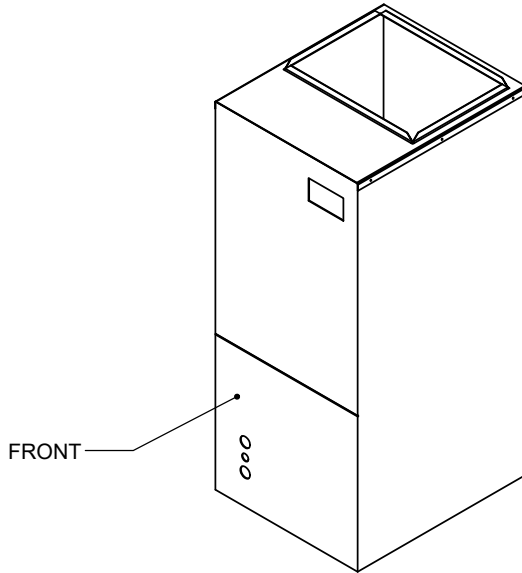

UNIT SIZE	PART NUMBER	CONTROL TYPE	"A"	"B"	"C"	EST. WT
AVC18-36B AVV25-38B AE18-36B JHETB18-36 JHVTB18-36	MB-AVB-AC-**	ACTUATOR ONLY	15-1/2"	14"	18- 1/2"	207 LBS.
	MB-AVB-DB-**	DRY BULB				
	MB-AVB-EN-**	ENTHALPY				
AVC36-60C AVV37C-61C AE36-60C JHETC36-60 JHVTC36-60	MB-AVC-AC-**	ACTUATOR ONLY	19"	18"	18-1/2"	270 LBS.
	MB-AVC-DB-**	DRY BULB				
	MB-AVC-EN-**	ENTHALPY				
AVC48-60D AVV49-61D AE48-60D JHETD48-60 JHVTD42-60	MB-AVD-AC-**	ACTUATOR ONLY	22-1/2"	18-1/2"	22"	333 LBS.
	MB-AVD-DB-**	DRY BULB				
	MB-AVD-EN-**	ENTHALPY				

**Damper Locations**

A, B, F, D, or E.  
First position as Return.  
(Added to end of part #)

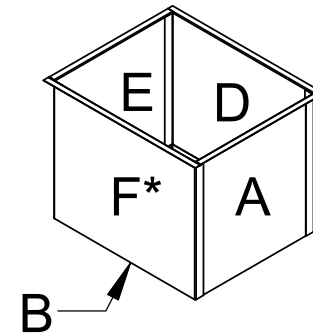

\* F Position represents front of Mixing Box which will always match to front of Air Handler.

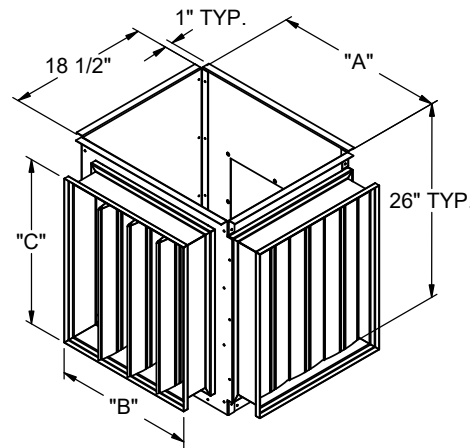

Example Shown  
P/N: MB-AV\*-\*\*-FA



3847 WABASH DRIVE  
MIRA LOMA, CA 91725

PHONE (951) 685-1101  
FAX (619) 872-9799

SUBMITTED TO: \_\_\_\_\_  
COMPANY: \_\_\_\_\_  
JOB NAME: \_\_\_\_\_  
EQUIPMENT: \_\_\_\_\_  
NOTES: \_\_\_\_\_

FORM NO:  
-

PART NUMBER:  
MB-AV SERIES

DATE:  
4/13/2023

REV:  
4

DRAWN BY:  
CNG