

**FEATURES**

- Stainless steel low leak damper side seals.
- External linkage system with manual locking quadrant.
- Mechanically secured upgraded outside air intake filter.
- Horizontal or down discharge. (Mounts in same position on unit).

**MANUAL OUTSIDE AIR HOOD PACKAGE 0-100% FOR YORK UNITS**

**DH/DM/BP 180  
&  
ZJ/ZF/DJ/ZR/WJ/DH/DR/WR/DM 180-300 BP/BQ 240**

PROVENT P/N

Wt.

OAMANSLM1830100 99 Lb.

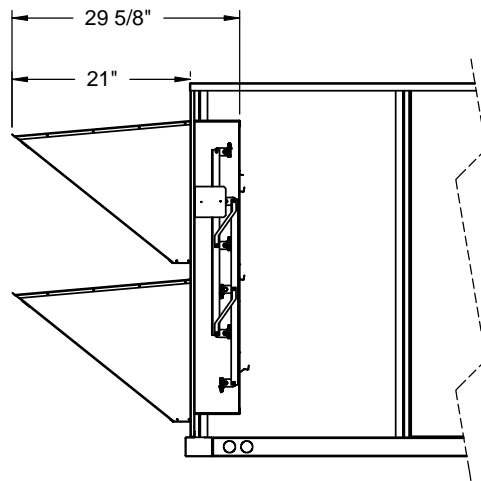
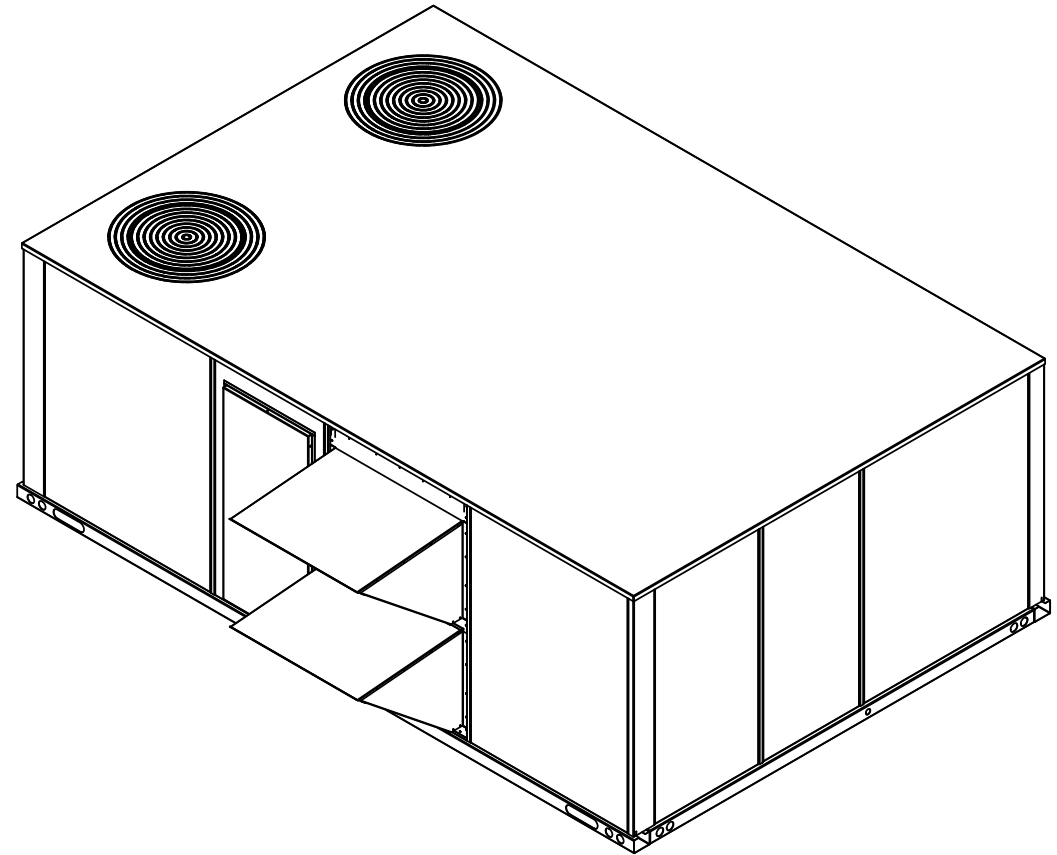

1392 EAST PALOMAR STREET  
SUITE 403-234  
CHULA VISTA, CA 91913

PHONE (619) 498-9246  
FAX (619) 872-9799

SUBMITTED TO: \_\_\_\_\_

COMPANY: \_\_\_\_\_

JOB NAME: \_\_\_\_\_

EQUIPMENT: \_\_\_\_\_

NOTES: \_\_\_\_\_

FORM NO:

OA-22

DATE:

7/29/2011

PART NUMBER:

OAMANSLM SERIES

REV:

1

DRAWN BY:

FMM