

**FEATURES:**

- 2-position option includes a built in damper position limit stop standard.
- CO2 capable option includes logic module with DCV.
- 2-10vdc Actuator standard.
- Ruskin CD60 low-leak dampers.
- External linkage system.
- Mechanically secured upgraded outside air intake filter. (19" X 16-1/16" X 7/8")
- Horizontal or down discharge applications.

**0-100% OUTSIDE AIR 2-POSITION AND CO2 CAPABLE HOOD FOR YORK UNITS**

PG3E, PC3E, PCG4A/B, PCE4A/B 24-60  
PCG6A/B, PCE6A/B, PHE4/6A/B, PHG4/6A/B 24-60

YORK UNIT	MODEL	ProVent P/N	WT.
PG3E, PC3E, PCG4A, PCE4A 24-42 PCG6A, PCE6A PHE4/6A, PHG4/6A 24-30	2-Position	OA2POLXS100BL	42 LBS.
	CO2 capable	OA2POLXS100VCO2	
PG3E, PC3E, PCG4B, PCE4B 48-60 PCG6B, PCE6B PHE4/6B, PHG4/6B 36-60	2-Position	OA2POLXL100BL	
	CO2 capable	OA2POLXL100VCO2	

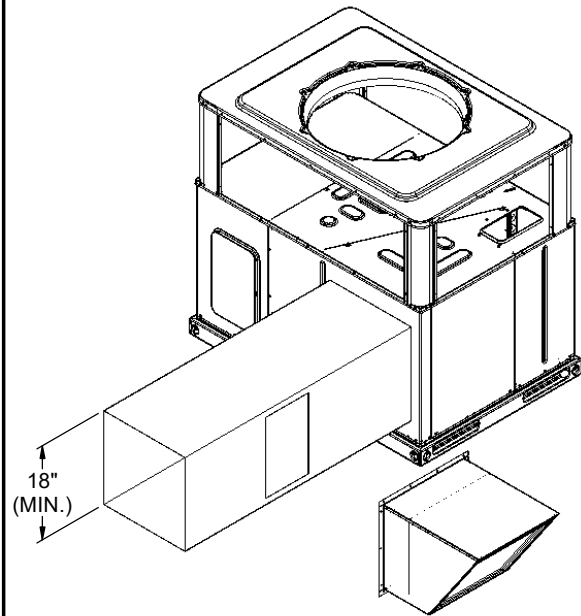

HORIZONTAL APPLICATION

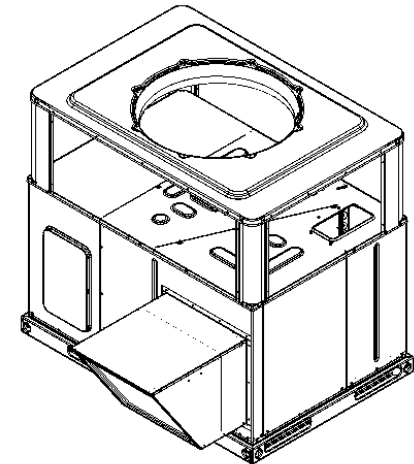
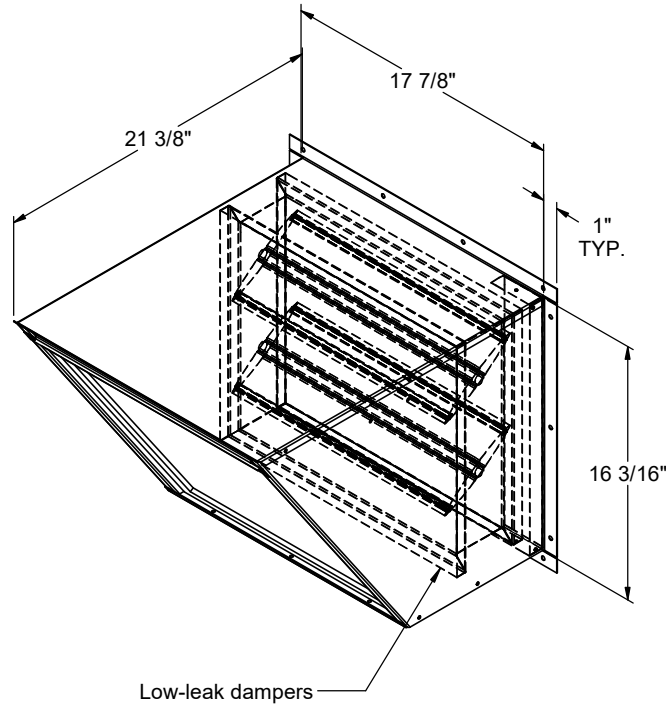

DOWN DISCHARGE APPLICATION



3847 WABASH DRIVE  
MIRA LOMA, CA 91752

PHONE (951) 685-1101  
FAX (619) 872-9799

SUBMITTED TO: \_\_\_\_\_  
COMPANY: \_\_\_\_\_  
JOB NAME: \_\_\_\_\_  
EQUIPMENT: \_\_\_\_\_  
NOTES: \_\_\_\_\_

FORM NO:  
OA-39

DATE:  
1/27/2025

REV:  
3

DRAWN BY:  
CNG