

**FEATURES:**

- Painted hood and panel match factory color.
- Designed for unit mounted down discharge and duct mounted horizontal discharge.
- Includes gravity backdraft damper.
- Insulated panel.

**0-35% OUTSIDE AIR PACKAGE FOR YORK UNITS**

ProVent P/N

WEIGHT

P\*\*\*A ALL MODELS

OALXS35

6 Lbs.

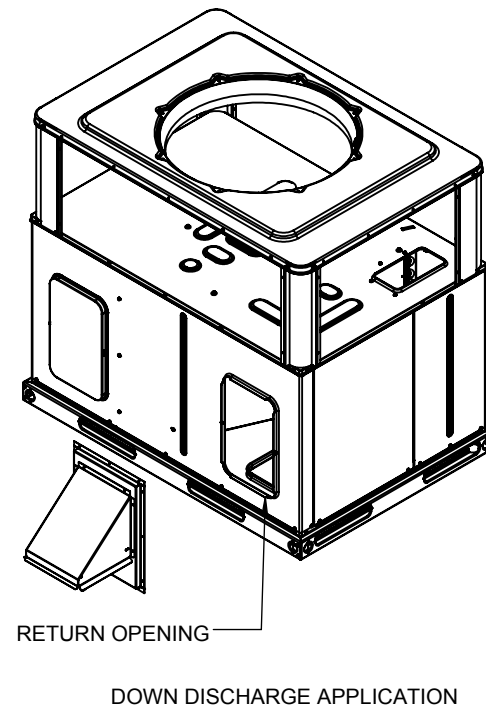
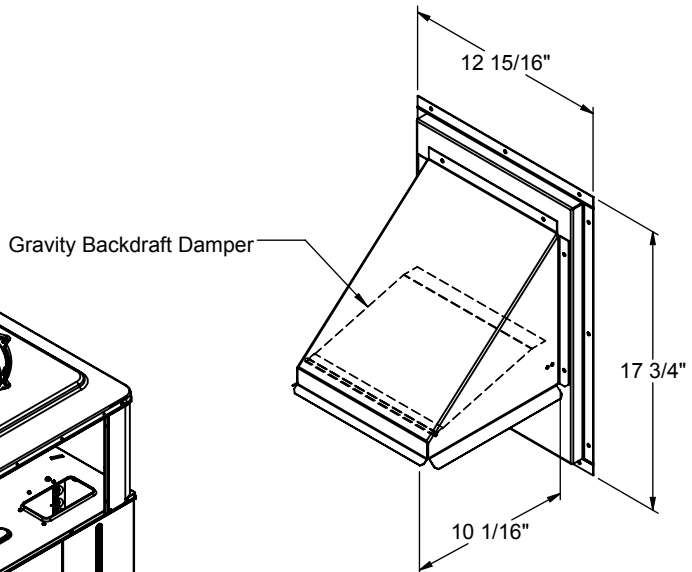
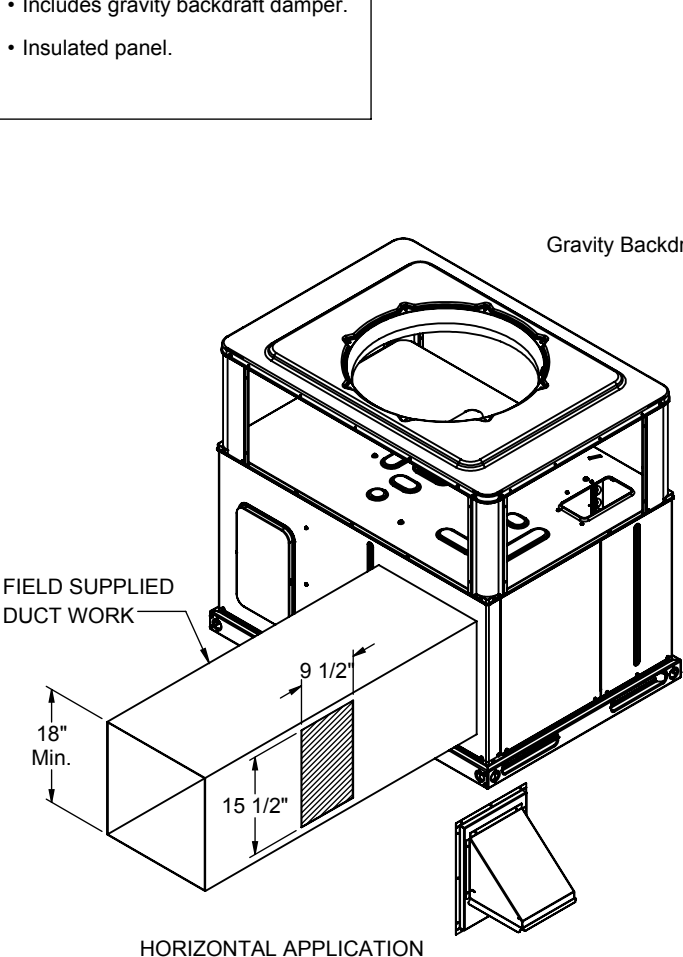

3847 WABASH DRIVE  
MIRA LOMA, CA 91752

PHONE (951) 685-1101  
FAX (619) 872-9799

SUBMITTED TO: \_\_\_\_\_  
 COMPANY: \_\_\_\_\_  
 JOB NAME: \_\_\_\_\_  
 EQUIPMENT: \_\_\_\_\_  
 NOTES: \_\_\_\_\_

FORM NO:  
OA-35

DATE:  
10/17/2016

REV:  
1

DRAWN BY:  
ALL