

Before Starting Installation

Warning

Severe injury can result from incorrect servicing. Only qualified HVAC service personnel should install, troubleshoot, repair or service HVAC and related HVAC equipment.

Always disconnect power before servicing. Please note some installation configurations may have more than one disconnect.

Important

Always follow all local building electrical codes.

Voltage	ProVent P/N	External Static Pressure (Inch W.G.)				FLA	Hp
		0.1	0.25	0.375	0.50		
208/230V/3Ph	PECCSLM182125C PECCSLM182125M	5, 952	5, 800	5, 648	5, 504	11.2	4 Hp Total (Qty. 2, 2 Hp)
460V/3Ph	PECCSLM182146C PECCSLM182146M					5.6	

PARTS INCLUDED	QTY.
#10 x 1/2 Sheet Metal Screw	23
3/16" Dia x 25' Pressure Tubing (w/Modulating Option Only)	1
Pressure Connection Port (w/Modulating Option Only)	1
Leg Kit	1
Blank Off Panel	1
VFD Instruction CD (w/Modulating Option Only)	1
VFD Instruction Booklet (w/Modulating Option Only)	1

ILL. 1

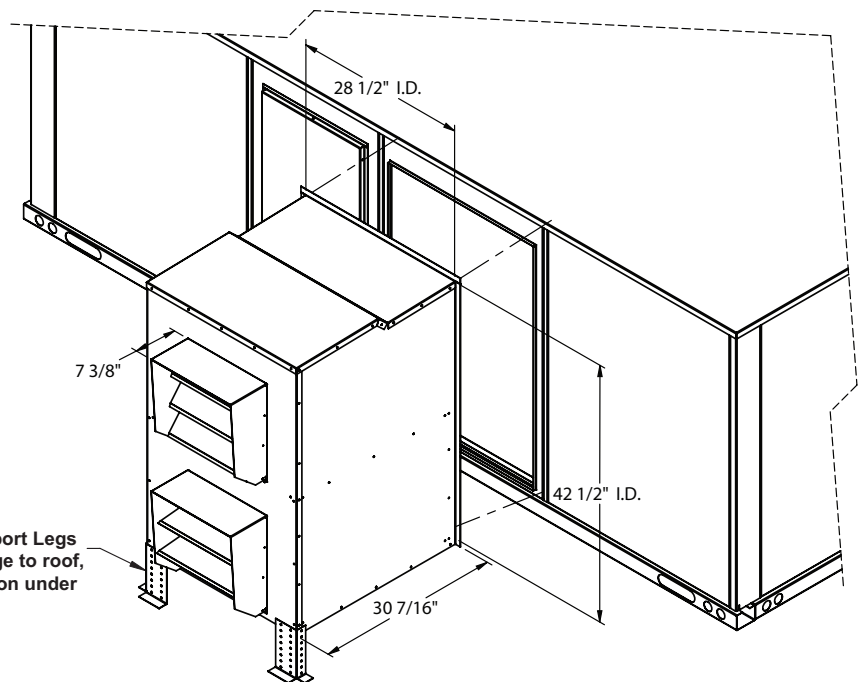

Horizontal Discharge

For horizontal discharge configuration, power exhaust needs to be mounted to horizontal duct leading to the unit. Allow clearance for economizer outside air hood.

Installation Instructions (Vertical Discharge, Steps 1 Thru 3)

1. Remove horizontal duct opening panel from unit. If unit does not have opening in panel, the entire panel needs to be removed. Locate passage way for wiring into unit. This will consist of four wires to economizer and economizer logic (constant volume) and line voltage (if wiring line voltage to unit control panel).

2. If entire panel needs to be removed, position power exhaust on bottom of opening. A factory included blank off is provided and positioned at top of power exhaust. (ILL. 2)
3. Install power exhaust over opening and secure to unit with sheet metal screws provided. Caulk all mating flanges water tight.
4. For constant volume units (2 stage), position one set of 24V wires (yellow-yellow) to economizer logic auxiliary switch and set accordingly. (See wiring diagram.) The other set, position field provided end switch to activate at 100% open damper position.

ILL. 2

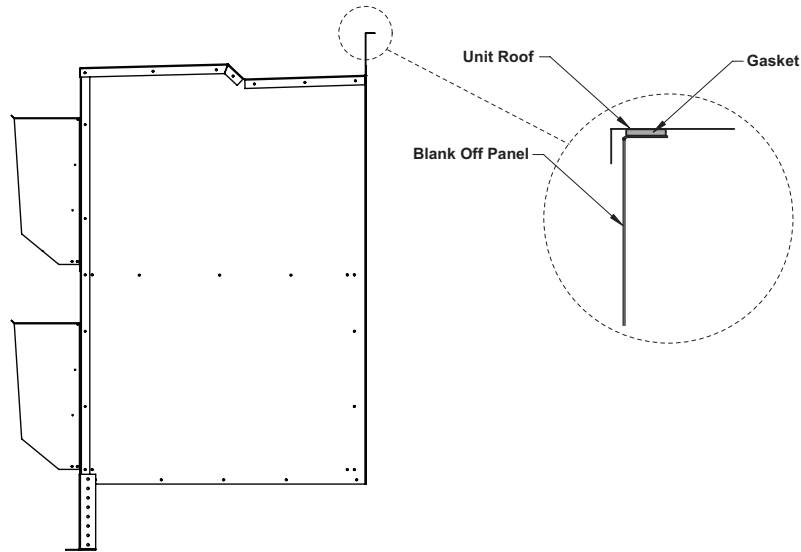

ILL. 3 - Constant Volume Power Exhaust Wiring

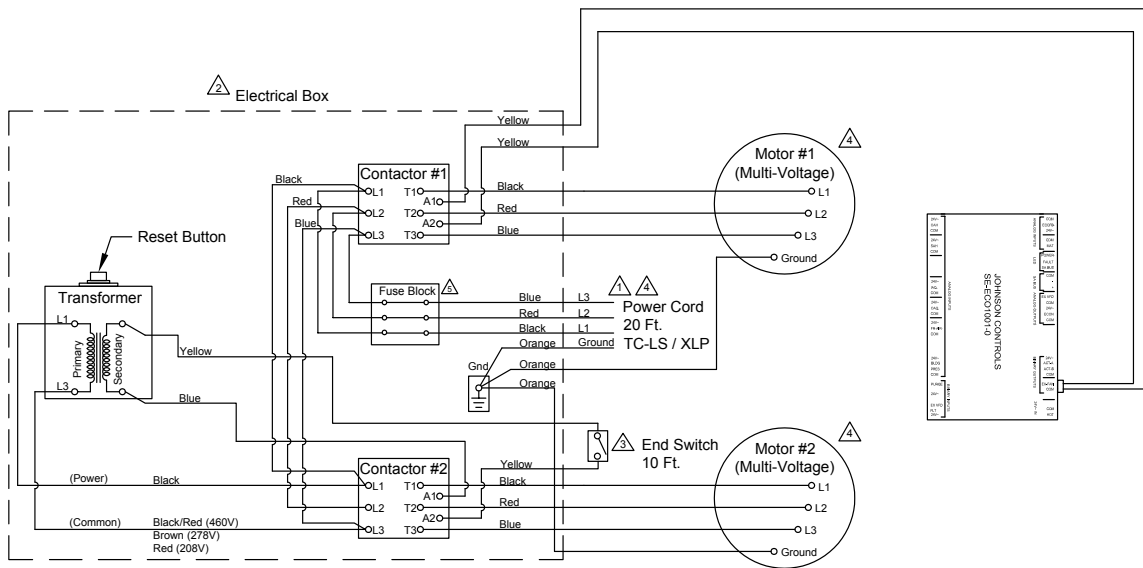

⚠️ Power Supply. Provide disconnect means and circuit protection as required. See power exhaust name plate for electrical ratings. If local codes allow connecting to the HVAC unit power, make sure the disconnect and incoming wiring are sized to handle the load of both the HVAC unit and the power exhaust.

To determine MCA with power exhaust: $\text{New MCA} = \text{MCA of Unit Only} + \text{MCA of Power Exhaust}$

⚠️ Transformer, contactor and fuses are to be in a NEMA type electrical enclosure.

⚠️ Field supplied end switch on economizer damper.

⚠️ For voltage, refer to label on exterior of power exhaust cabinet.

⚠️ For fuses, refer to label on exterior of Power Exhaust cabinet.

Example: With a unit that has MCA=22.5 amps and MOCP=30 amps,
 New MCA = 22.5 amps + 3 amps (example for power exhaust) = 25.5 amps

If New MCA is less than MOCP for the HVAC unit, you can tie the power wire to the HVAC contactor terminal strip, if local code allows. Make sure tap off terminal block is capable for handling more than one unit.

If new MCA is greater than MOCP or local code requires, you must run power wire for the power exhaust to an external disconnect. Make sure the disconnect is sized properly for the power from the power exhaust as well as the HVAC unit.

ILL. 4 - Modulating Power Exhaust Option Wiring

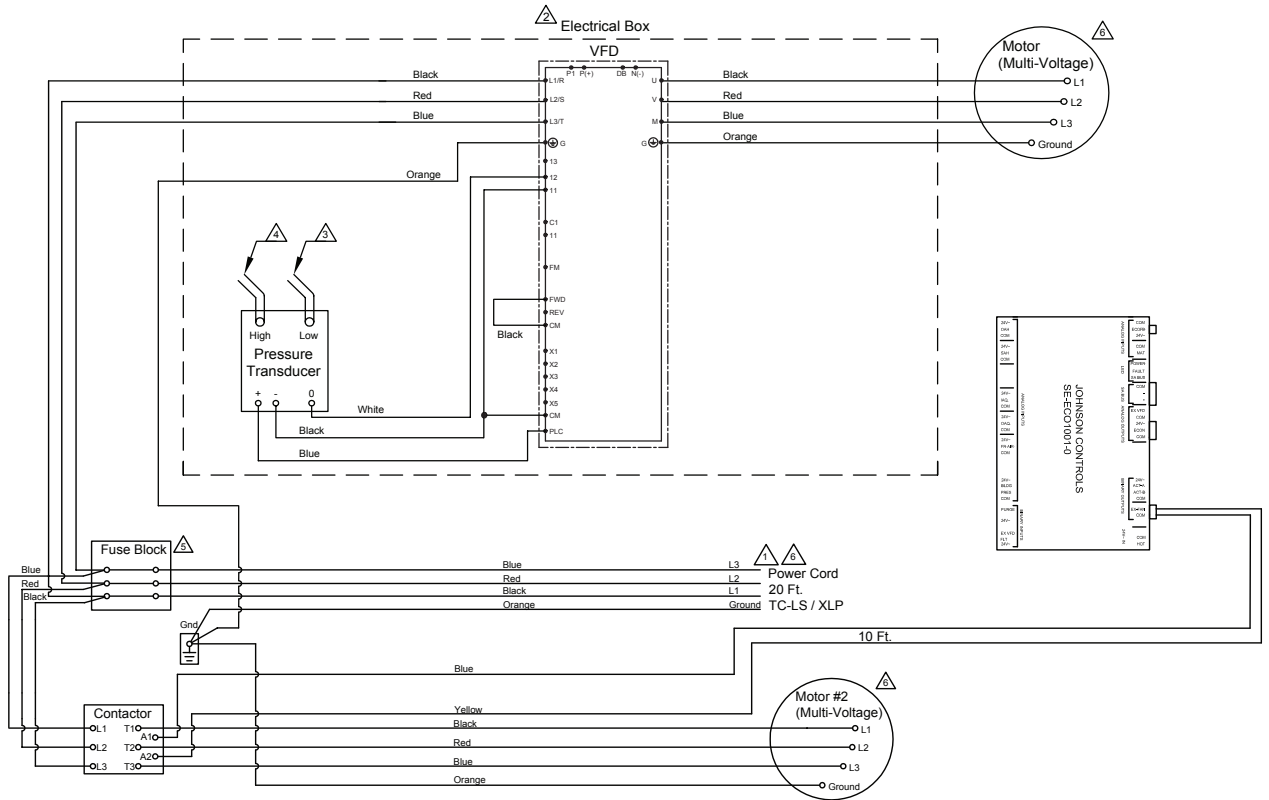

⚠ Power Supply. Provide disconnect means and circuit protection as required. See power exhaust name plate for electrical ratings. If local codes allow connecting to the HVAC unit power, make sure the disconnect and incoming wiring are sized to handle the load of both the HVAC unit and the power exhaust.

To determine MCA with power exhaust: $\text{New MCA} = \text{MCA of Unit Only} + \text{MCA of Power Exhaust}$

- ⚠ Transformer, contactor and fuses are to be in a NEMA type electrical enclosure.
- ⚠ Factory mounted 3/16" low pressure tubing.
- ⚠ 25 feet of 3/16" high pressure tubing and connection port provided for field mounting in conditioned space. Architectural finishing field provided. (Follow local codes.)
- ⚠ 9 amp KTK fuses (460V). 15 amp KTK fuses (230V)
- ⚠ For voltage, refer to label on exterior of power exhaust cabinet.

If the Power Exhaust is installed with the Simplicity Smart Equipment (SSE) board, please change the following fan type settings:

Details <enter>

Control <enter>

Power Ex <enter>

Ex FType <enter>

"select" Non-Modulating <enter>

To change the setpoints for "ON" and "OFF"

EconDmpPos- FanOn <60% default>

EconDmpPos- FanOff <20% default>

The two blower modulating power exhaust has one motor/blower that will turn on at field determined O/A. This is achieved by wiring to the economizer logic auxiliary switch and setting the potentiometer. The other motor/blower is connected to a motor controller (VFD) that varies the speed to maintain an acceptable conditioned space pressure. The power exhaust system includes a low pressure transducer that compares room pressure to atmospheric. This transducer sends a signal to the motor controller (VFD) which varies the motor frequency in order to provide pressure relief.

1. Install 3/16" pressure tubing as per wiring diagram making sure it is not located near any S/A or R/A diffuser or door.
2. The VFD is factory pre programmed to accept the 0 to 10 VDC signal through the pressure transducer.

Table 1 - Pressure vs. VFD Frequency

Transducer Output Signal (VDC)	Conditioned Space Pressure (Inch W.G.)	VFD Setting (Hz)
0	0	0
1	0.01	10
2	0.02	20
3	0.03	30
4	0.04	40
5	0.05	50
6	0.06	60
7	0.07	70
8	0.08	80
9	0.09	90
10	0.10	100

VFD is factory set at 0.04 inches w.g. To change setting, press and hold "OK" to access the programming menu; up/down to display P-45, hit "OK" move arrows up/down to set desired frequency that determines pressure requirement, then press "OK" to save parameter.