

**FEATURES**

- Roof curb perimeter made of 16 ga. galvanized steel.
- Gasketing package provided.
- Heat treated wood nailer provided.
- Pitched, adjustable pitch/adjustable height, welded, different height, isolation and calculated curbs are available.

**NOTES**

- Attach ductwork to roof curb. Flanges of duct rest on top of the curb. Support ductwork below the curb.

**WELDED ROOF CURB FOR ALLIED UNITS**

LGH/LCH 036-072 S/H  
KGA/KCA 024-072S; KHA 024-060S

PROVENT P/N	A	EST. WEIGHT
CBWABX08	8"	61 Lbs.
CBWABX11	11"	81 Lbs.
CBWABX14	14"	95 Lbs
CBWABX24	24"	142 Lbs

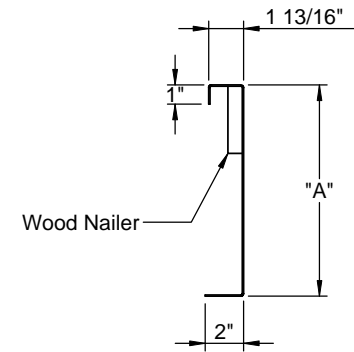
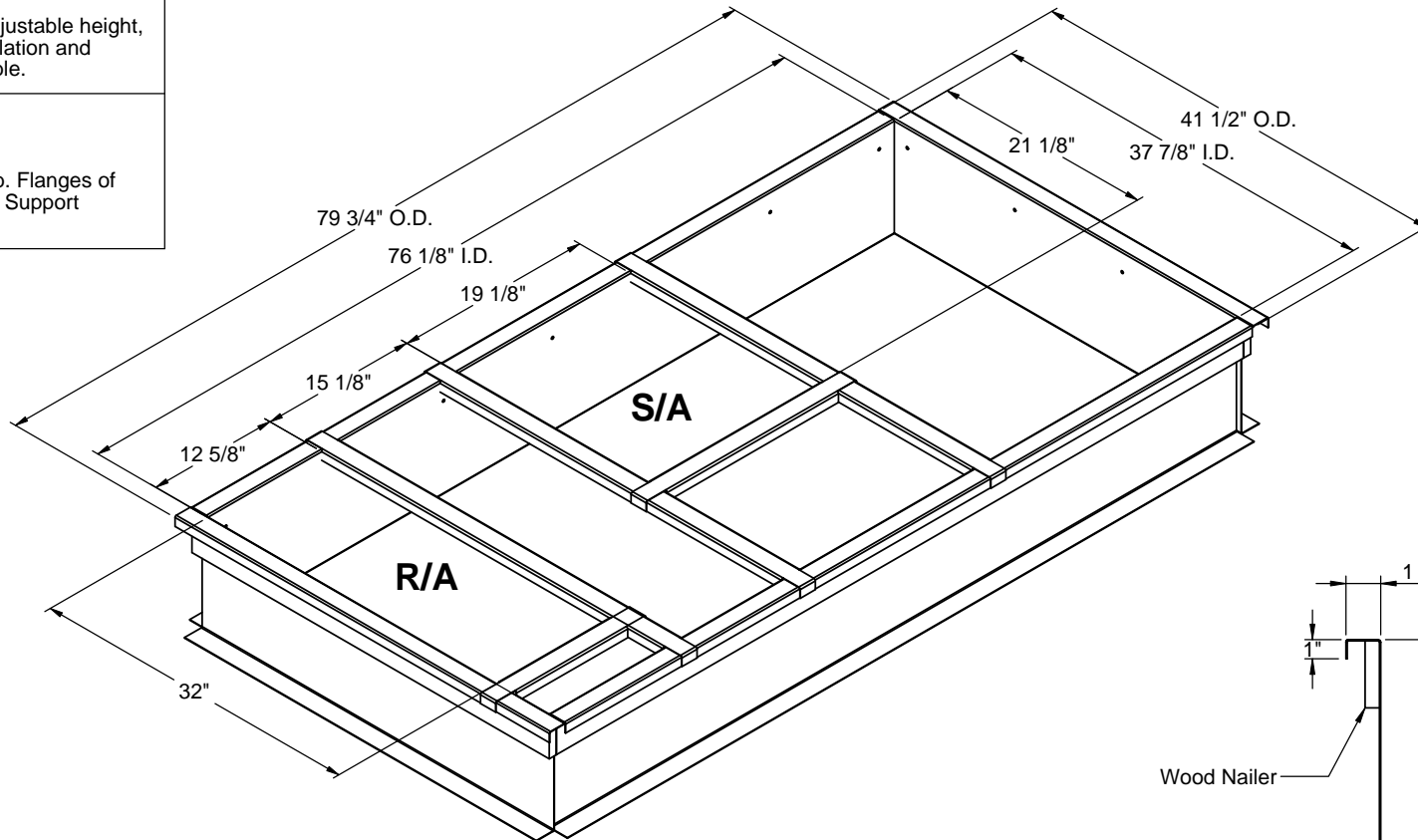

**CROSS SECTION DETAIL**



3847 WABASH DR.  
MIRA LOMA, CA 91725

PHONE (951) 685-1101  
FAX (619) 872-9799

SUBMITTED TO: \_\_\_\_\_  
COMPANY: \_\_\_\_\_  
JOB NAME: \_\_\_\_\_  
EQUIPMENT: \_\_\_\_\_  
NOTES: \_\_\_\_\_

FORM NO:  
CBW-202

PART NUMBER:  
CBWABX SERIES

DATE:  
6/17/2013

REV:  
-

DRAWN BY:  
CNG