

FEATURES

- Roof curb perimeter made of 16 ga. galvanized steel.
- Gasketing package provided.
- Heat treated wood nailer provided.
- Pitched, adjustable pitch/adjustable height, welded, different height, isolation and calculated curbs are available.

NOTES

- Attach ductwork to roof curb. Flanges of duct rest on top of the curb. Support ductwork below the curb.

WELDED ROOF CURB FOR ALLIED UNITS

LGH/LCH 156-240H, 300S
KGA/KCA 180-300S; KHA 180-240S

PROVENT P/N	A	EST. WEIGHT
CBWCBX08	8"	119 Lbs.
CBWCBX11	11"	135 Lbs.
CBWCBX14	14"	151 Lbs.
CBWCBX16	16"	172 Lbs.
CBWCBX24	24"	201 Lbs

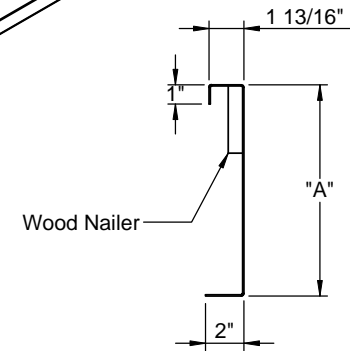
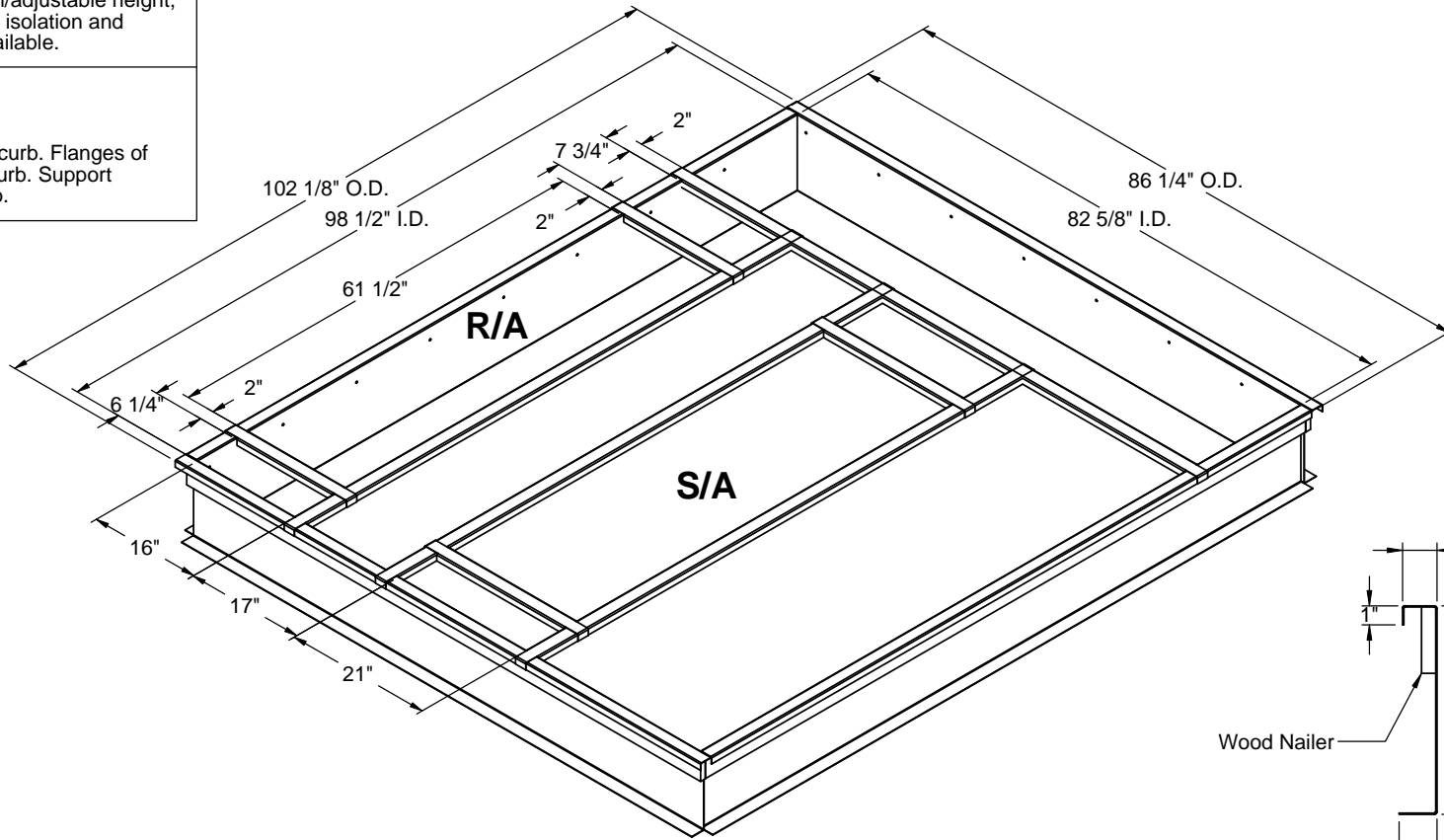

CROSS SECTION DETAIL



3847 WABASH DR.
MIRA LOMA, CA 91725

PHONE (951) 685-1101
FAX (619) 872-9799

SUBMITTED TO: _____
COMPANY: _____
JOB NAME: _____
EQUIPMENT: _____
NOTES: _____

FORM NO:
CBW-204

PART NUMBER:
CBWCBX SERIES

DATE:
11/15/2013

REV:
-

DRAWN BY:
CNG