

FEATURES:

- Material: 18 Ga. Bright Galv.
- Gasketing package provided.
- Heat treated wood nailer provided.
- Estimated Weight: 75 Lbs.

CURB ADAPTER

FOR YORK UNITS:
 DEB/BHH/BHA 018-060: DNZ/DEZ/DNP/DEM/BHZ/BHP 024-060: DEX 024-048:
 DNH/DEH 030-060: DNA 036-060: DNY/BHX 024, 036, 048, 060: DNX 024, 036, 048: DEY 060

EXISTING CARRIER:
 FACTORY CURB LARGE CABINET 48/50N* 018-060

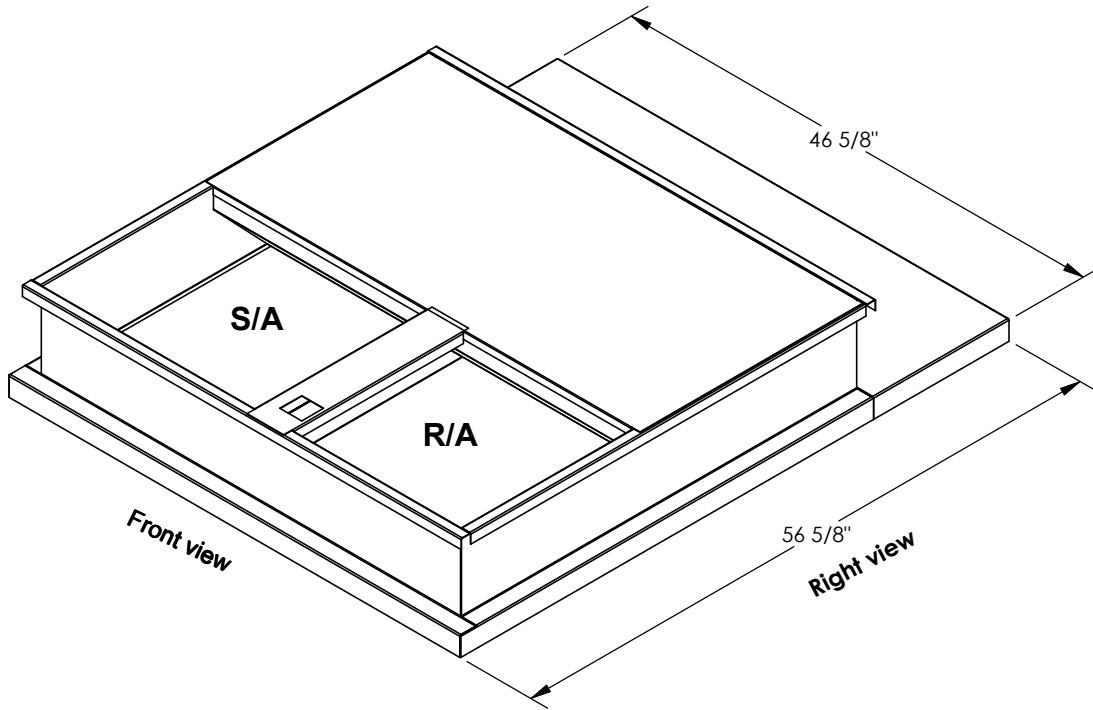

ISOMETRIC VIEW

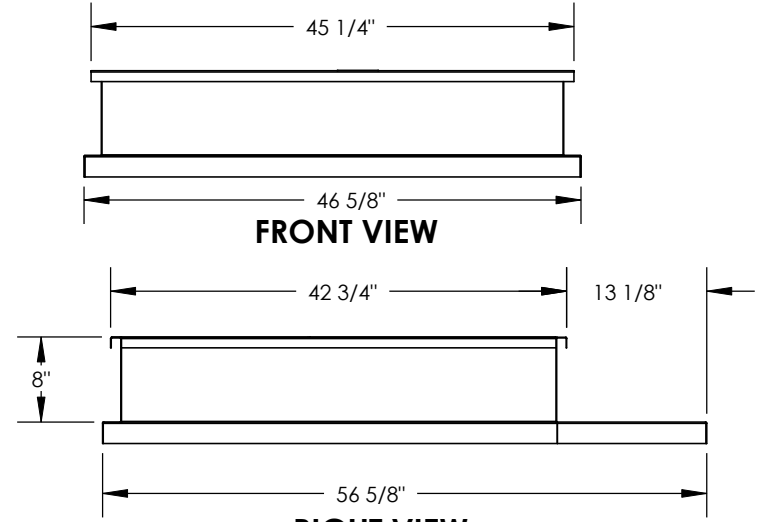

FRONT VIEW

RIGHT VIEW

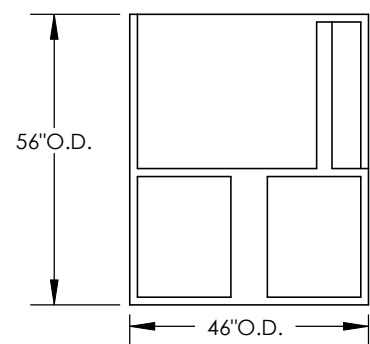

EXISTING CURB



1392 EAST PALOMAR STREET
 SUITE 403-234
 CHULA VISTA, CA 91913
 PHONE (619) 498-9246
 FAX (619) 872-9799

SUBMITTED TO: _____
 COMPANY: _____
 JOB NAME: _____
 EQUIPMENT: _____
 NOTES: _____

FORM NO: _____
 -
 DATE: 3/9/2009

PART NUMBER: CA-AFF1860-CAR07
 REV: 2
 DRAWN BY: COC