

FEATURES:

- Gasketing package provided.
- Insulation: 1"-1.5 lb. Density.
- Estimated Weight: 89 Lbs.
- All Galvanized Welded Construction.

CURB ADAPTER

EXISTING CARRIER:
50 TH,TQ,YH,YQ,YM; 024-060, 50EE/QQ 018-060
EXISTING BRYANT:
542G,559G,018-060; 542E,559E 024-036.

FOR YORK UNITS:
DEB/BHH/BHA 018-060: DNZ/DEZ/DNP/DEM/BHZ/BHP 024-060: DEX 024-048:
DNH/DEH 030-060: DNA 036-060: DNY/BHX 024, 036, 048, 060: DNX 024, 036, 048: DEY 060

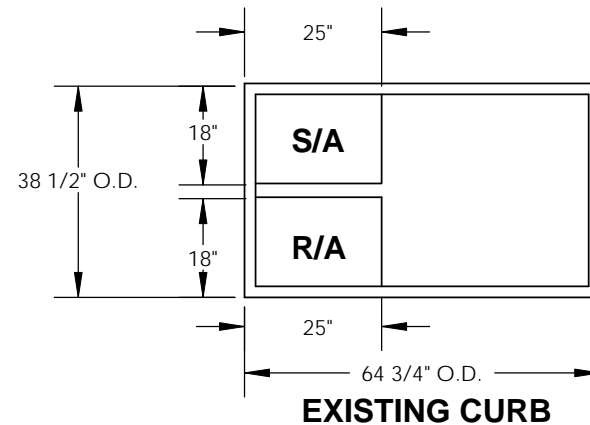
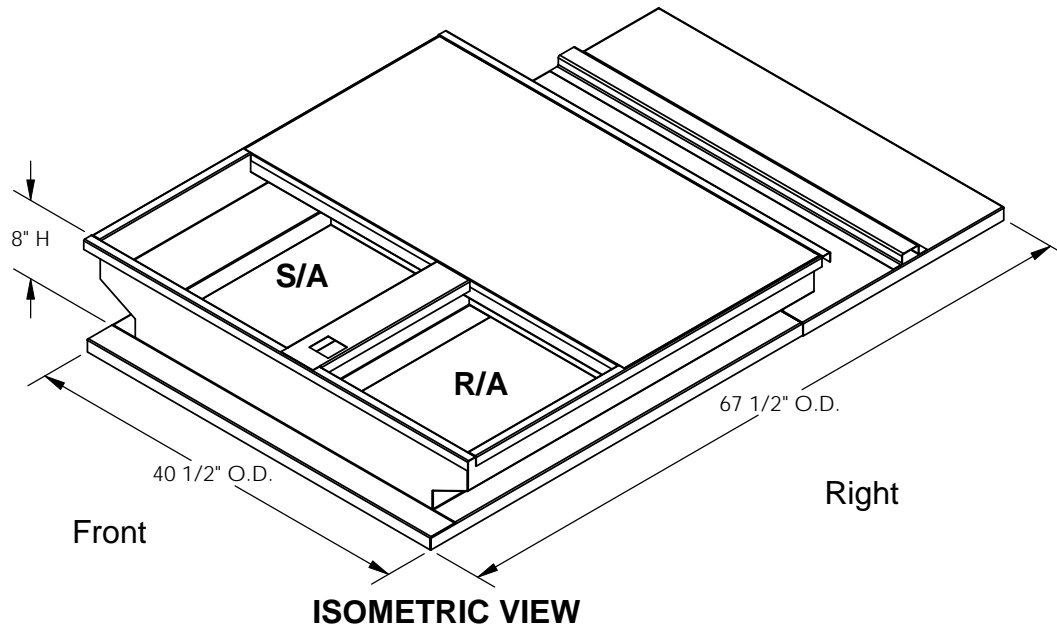
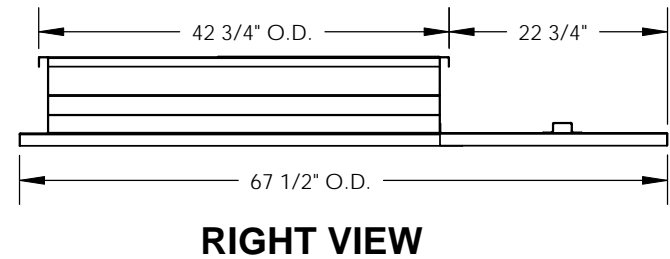
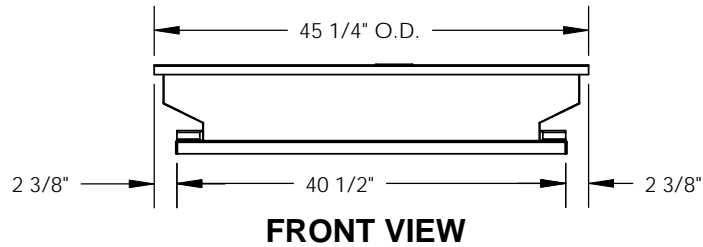

3847 WABASH DRIVE
MIRA LOMA, CA 91752

PHONE (951) 685-1101
FAX (619) 872-9799

SUBMITTED TO: _____
COMPANY: _____
JOB NAME: _____
EQUIPMENT: _____
NOTES: _____

FORM NO:

PART NUMBER:
CA-AFF1860-CAR12

DATE:
6/11/2014

REV:
5

DRAWN BY:
CNG