

FEATURES:

- Gasketing package provided.
- Insulation: 1"-1.5 lb. Density.
- Estimated Weight: 167 Lbs.
- All Galvanized Welded Construction.

CURB ADAPTER

EXISTING BRYANT:
542E, 559E 024-036; 542G, 559G 018-060

FOR YORK UNITS:
DM/DR/DCE/DCG/BP 036-072:
ZJ/XP/DY/DJ/DH/DHE/DHG/BQ/BCH/036-060: DF 072

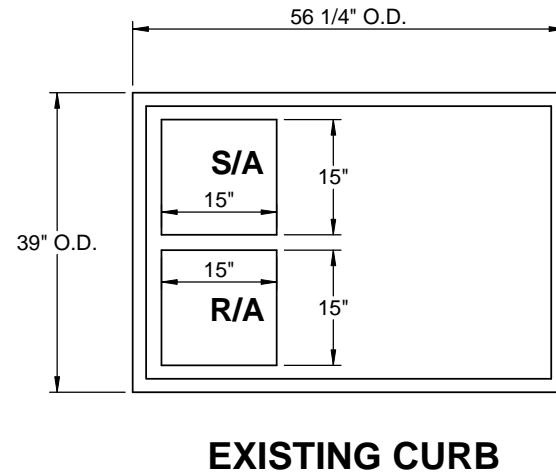
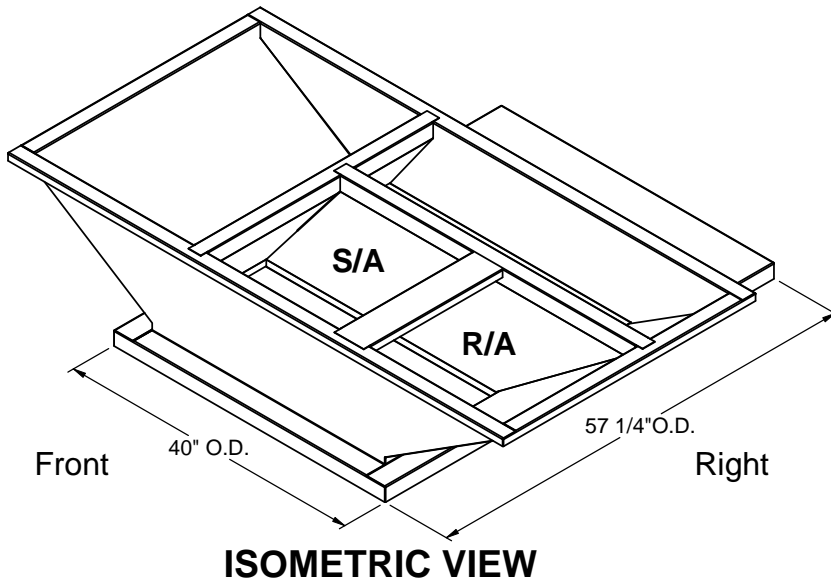
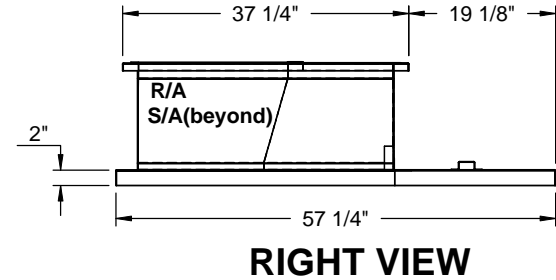
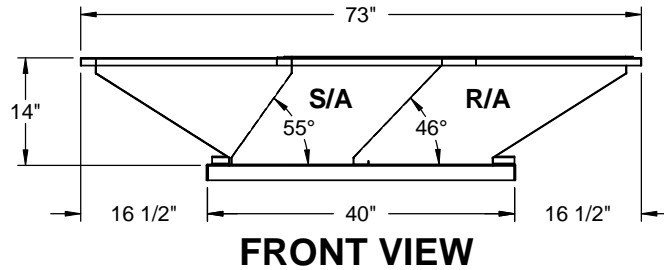

3847 WABASH DRIVE
MIRA LOMA, CA 91752

PHONE (951) 685-1101
FAX (619) 872-9799

SUBMITTED TO: _____
COMPANY: _____
JOB NAME: _____
EQUIPMENT: _____
NOTES: _____

FORM NO: _____
DATE: 9/13/2011

PART NUMBER: CA-SUN3672-BDP03
REV: -
DRAWN BY: CNG