



INSTALLATION INSTRUCTIONS CBAKDPRD7815 Series Roof Curbs

ProVent roof curbs have been designed to optimize structural code building requirements while at the same time minimizing the installation procedure. Please read these instructions carefully before beginning.

ROOF CURB LIST OF MATERIALS										
Roof Curb Part No.	Height	Tek Screw #14x3/4"	Tek Screw #12x3/4"	Top Sides	Top Ends	Base Sides	Base Ends	Duct Supports	Deck Pans	Gasket 1-1/2" x 1/4" x 10' 1-1/2" x 1/4" x 23'
CBAKDPRD781508	8"	21	53	2	2	2	2	2	5	33 ft.
CBAKDPRD781511	11"									
CBAKDPRD781514	14"									

Instructions

Adjustable pitch curb is for roofs with pitches up to 1" in 12".

Part No.	H
CBAKDPRD781508	8"
CBAKDPRD781511	11"
CBAKDPRD781514	14"

- Remove curb from package and separate parts for top section, base section and decks/supports. **(As shown in ILL. 1)**

- Base: Attach (2) sides and (2) ends. Attachment flanges on ends go to inside of sides.

Use #14x3/4" tek screws in each corner to assemble. Screws are inserted from outside curb inwards.

- Top: Assemble (2) sides and (2) ends. Attachment flanges on ends go to inside of sides.

Use #14x3/4" tek screws in each corner to assemble. Top screw will go into wood nailer. Screws are inserted from inside curb outward.

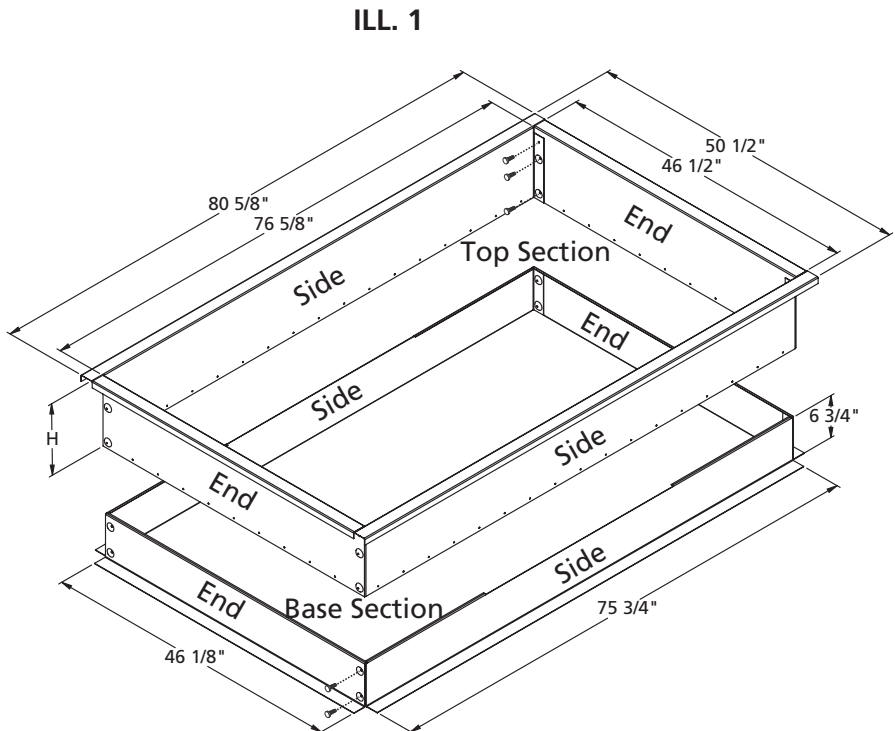

ADJUSTABLE PITCH / ADJUSTABLE HEIGHT CURB INSTRUCTIONS (CONTINUED)

- Set (4) deck pans at compressor end of curb. (Deck pans 48" in total length.) Deck pan with side slots is positioned closest to supply opening of roof curb. Refer to **ILL. 2** for positioning. The shortest deck pan measuring 47-1/2" is set behind the supply air and return air openings of curb.

The duct support separating supply and return openings is set in position by slot in length of duct support running behind the openings.

- Square up curb by measuring diagonally across curb corners. Set curb in place over roof opening.
- Manufacture duct and drop into curb supply air and return air openings. Install gasket around top perimeter of curb and around top duct flanges.
- Locate base assembly over roof openings. Roof opening sizes listed in HVAC unit specifications are appropriate. Secure bottom section to roof.

- Slide top section over bottom section. Level top section and clamp in place. (**ILL. 3**)

Note:

This curb can be used on roofs with pitch up to 1" in 12". If curb is pitched on short side, roof pitch can be even greater.

- Through pre-punched holes along bottom base of top section, insert #12 x 3/4" tek screws. This will secure top section to bottom section. (**ILL. 4**)

Pre-punch holes are 6" apart. **It is important that you install the screws through every hole.**

- Roof in curb according to local or other appropriate codes.
- Manufacture supply and return duct according to dimensions shown in **Table 1**.

TABLE 1

DUCT SIZE	
Return Duct	Supply Duct
19-1/8" x 29-1/8"	19-1/8" x 29-1/8"

ILL. 2

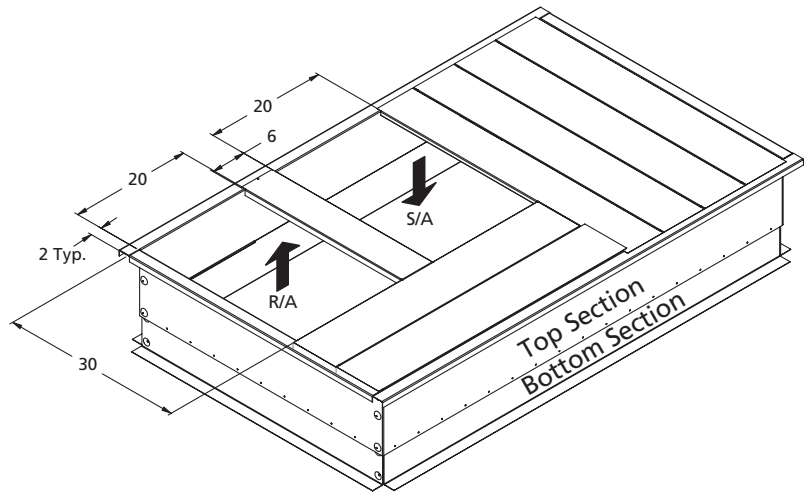

ILL. 3

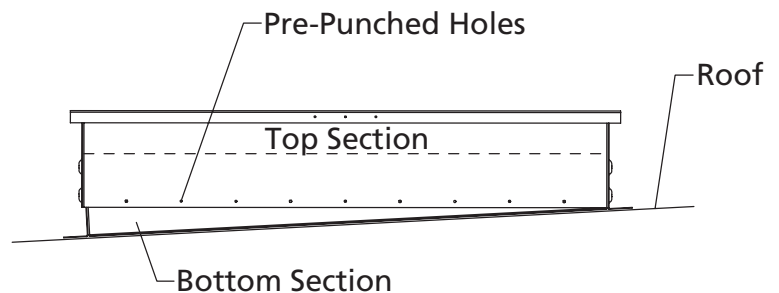

ILL. 4

