

FEATURES

- Roof curbs sides and ends are 16 ga.
- Fully welded construction.
- Gasketing package provided.
- Heat treated wood nailer provided.
- Insulated deck pans provided.
- Pitched curbs and taller curbs are available.

NOTES

- Attach ductwork to roof curb. Flanges of duct rest on top of the curb, Support ductwork below the curb.
- Thru the curb utilities are available. Contact you York distributor or Provent directly.

VIBRATION ISOLATION ROOF CURBS FOR YORK UNITS*

ZT, ZH, ZJ, ZR, KT, KJ 037-150; ZF, XP, ZB, WP, KB, DH, DM, DF, DR, BP 078-150

* FACTORY CURB DESIGN

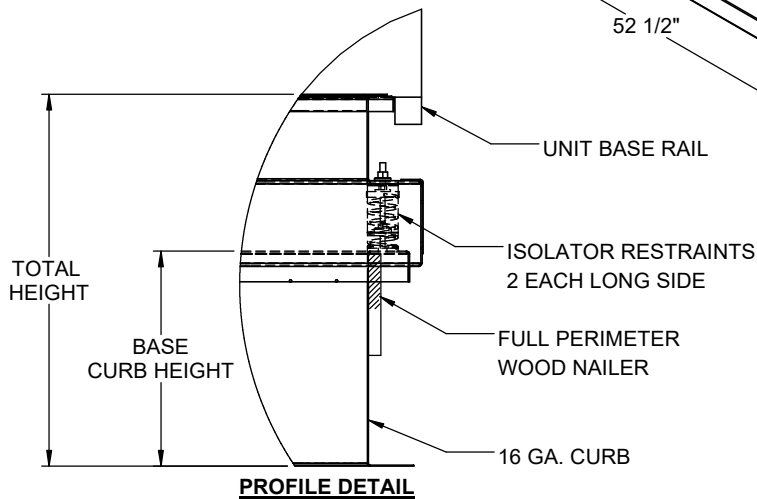
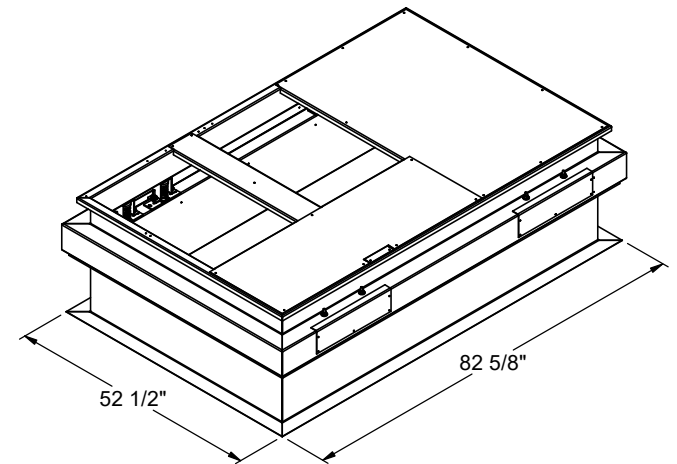
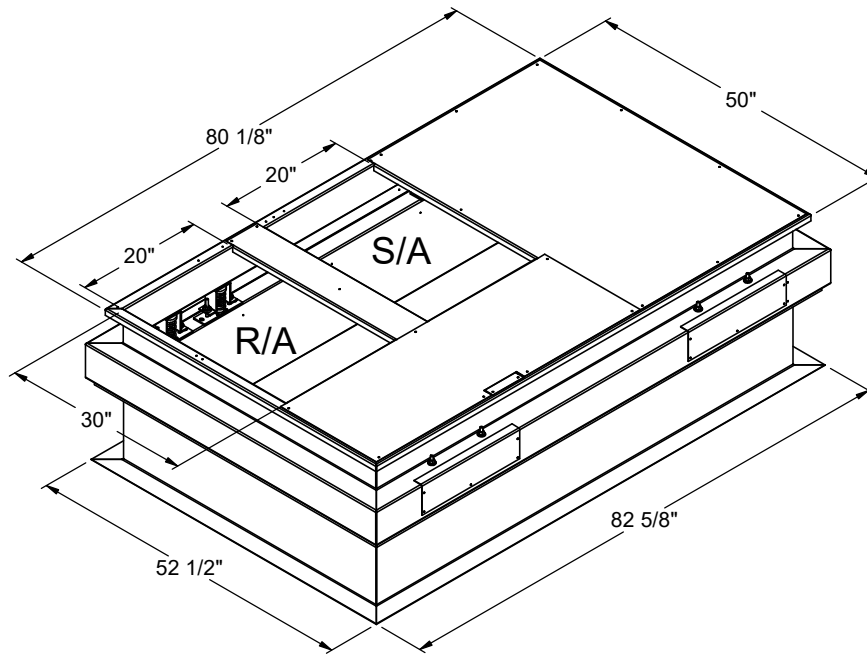

PROVENT P/N	BASE HEIGHT	TOTAL HEIGHT	EST. WEIGHT
CBISPRD7815**18	08"	18"	220 Lbs.
CBISPRD7815**21	11"	21"	250 Lbs.
CBISPRD7815**24	14"	24"	280 Lbs.

**Note: Spring configuration must be added to part number at time of order. See Price Guide for details.



**3847 WABASH DRIVE
MIRA LOMA, CA 91752**

**PHONE (951) 685-1101
FAX (619) 872-9799**

SUBMITTED TO: _____
COMPANY: _____
JOB NAME: _____
EQUIPMENT: _____
NOTES: _____

FORM NO:
CBIS-103

DATE:
2/5/2025

PART NUMBER:
CBISPRD7815

REV:
1

DRAWN BY:
CNG