

For wood, concrete and steel attachment, see Roof Anchorage Detail Form No. CB-62.

VIBRATION ISOLATION ROOF CURBS FOR YORK UNITS

PROVENT P/N	A	B	EST. WEIGHT
CBISPRD371518**	8"	18"	278 Lbs.
CBISPRD371521**	11"	21"	296 Lbs.
CBISPRD371524**	14"	24"	318 Lbs.

FEATURES

- Roof curbs sides and ends are 16 ga.
- Fully welded construction.
- Gasketing package provided.
- Heat treated wood nailer provided.
- insulated deck pans provided.
- Pitched curbs and taller curbs are available.

ZT, ZH, ZJ, ZR, KT, KJ 037-150
ZF, XP, ZB, WP, KB, DH, DM, DF, DR, BP 078-150

****Note:** Spring configuration must be added to part number at time of order. See Price Guide for details.

NOTES

- Attach ductwork to roof curb. Flanges of duct rest on top of the curb, Support ductwork below the curb.

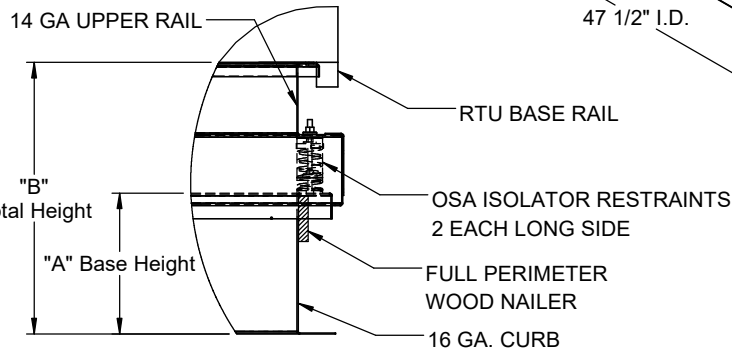
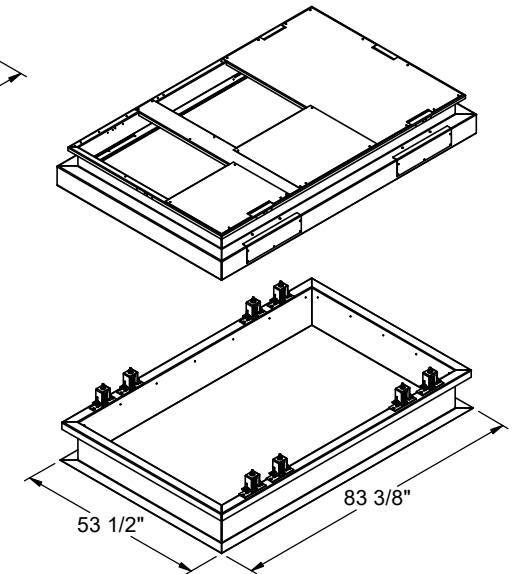
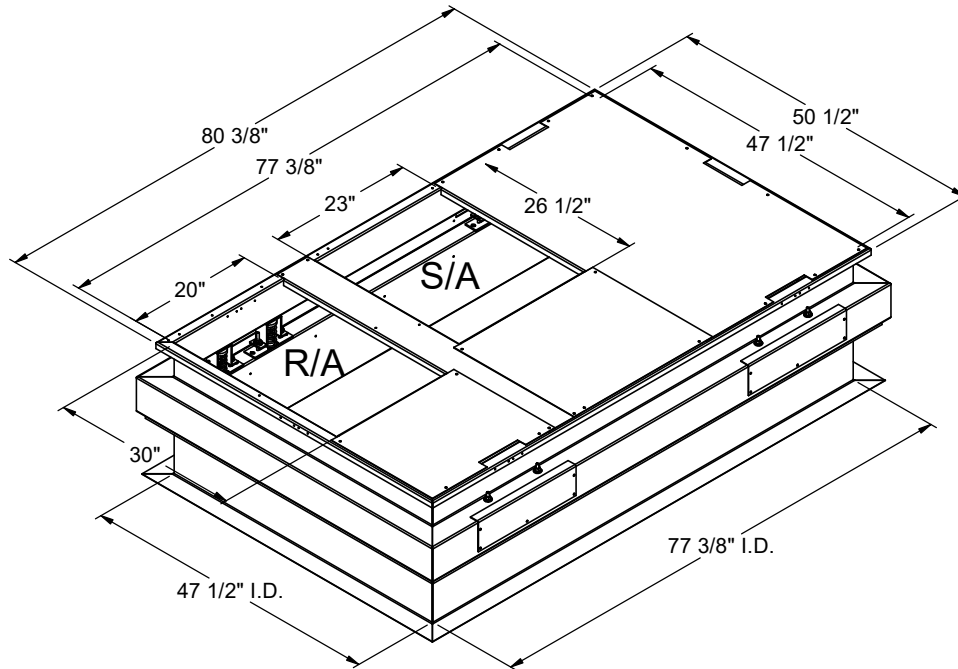

PROFILE DETAIL

EXPLODED DETAIL



3847 WABASH DRIVE
MIRA LOMA, CA 91752

PHONE (951) 685-1101
FAX (619) 872-9799

SUBMITTED TO: _____
COMPANY: _____
JOB NAME: _____
EQUIPMENT: _____
NOTES: _____

FORM NO:
CBIS-108

PART NUMBER:
CBISPRD3715 SERIES

DATE:
1/10/2025

REV:
2

DRAWN BY:
CNG