

FEATURES:

- Roof curb sides and ends are 16 ga. galvanized steel.
- Fully welded construction.
- Gasketing package provided.
- Heat treated wood nailer provided.
- Insulated deck pan provided.
- Pitched curbs and taller curbs are available.
- CalDyn OSHPD pre-approved 2" deflection seismic restraints. (OPA-0070) JQA.

NOTES

Attach ductwork to roof curb. Flanges of duct rest on top of curb. Support ductwork below the curb.

VIBRATION ISOLATION ROOF CURB FOR YORK UNITS

**ZX04-07; XXA7, ZXA7
ZY, ZQ, XY, XQ, ZL04-06**

PROVENT P/N	A	B	WEIGHT
CBISPRS18**	8"	18"	230 Lbs.
CBISPRS21**	11"	21"	250 Lbs.
CBISPRS24**	14"	24"	270 Lbs.

**Note: Spring configuration must be added to part number at time of order.

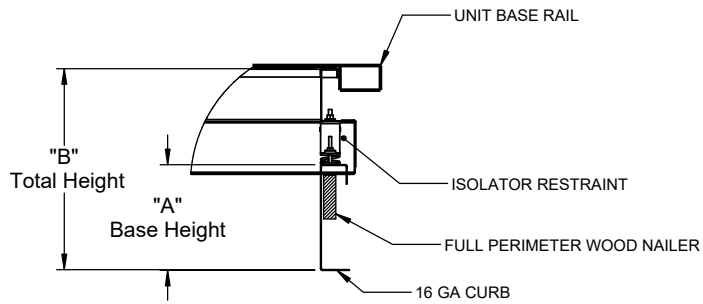
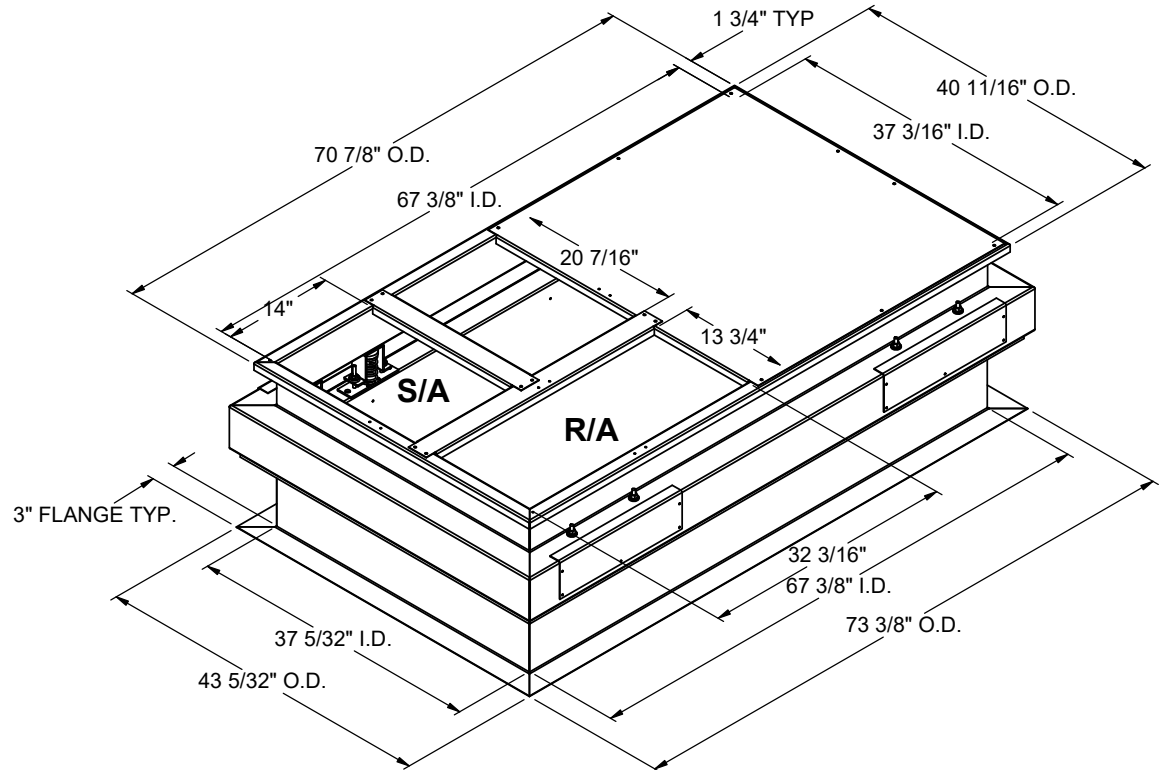

SIDE VIEW DETAIL



3847 WABASH DR.
MIRA LOMA, CA 91752

PHONE (951) 685-1101
FAX (619) 872-9799

JOB NAME: _____
 ADDRESS: _____

 NOTES: _____

FORM NO:
CBIS-117

DATE:
3/17/2022

PART NUMBER:
CBISPRL SERIES

REV:
5

DRAWN BY:
FMM