

For wood, concrete and steel attachment see Roof Anchorage Detail, Form No. CB-60.

Welded isolation springs housing are standard. For bolted spring housing, neoprene pads and spring cups see Weldment and Bolting Detail, Form No. CB-61

FEATURES

- Roof curbs sides and ends are 16 ga.
- Fully welded construction.
- Gasketing package provided.
- Heat treated wood nailer provided.
- Insulated deck pans provided.
- Pitched curbs and taller curbs are available.

NOTES

- Attach ductwork to roof curb. Flanges of duct rest on top of the curb, support ductwork below the curb.
- Thru the curb utilities are available. Contact your York distributor or Provent directly.

VIBRATION ISOLATION ROOF CURB FOR YORK UNITS

P***A CABINET

PROVENT P/N	A	B	EST. WEIGHT
CBISLXS18*	8"	18"	142 Lbs.
CBISLXS21**	11"	21"	160 Lbs.
CBISLXS24**	14"	24"	178 Lbs.

**Note: Spring configuration must be added to part number at time of order

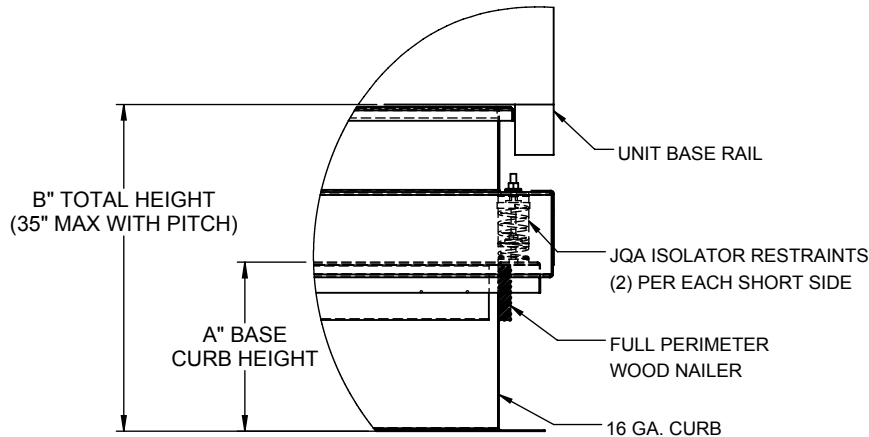
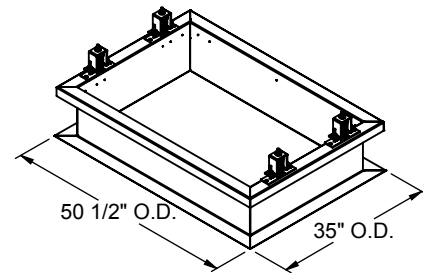
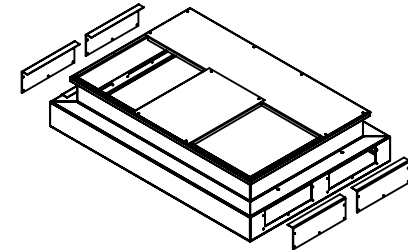
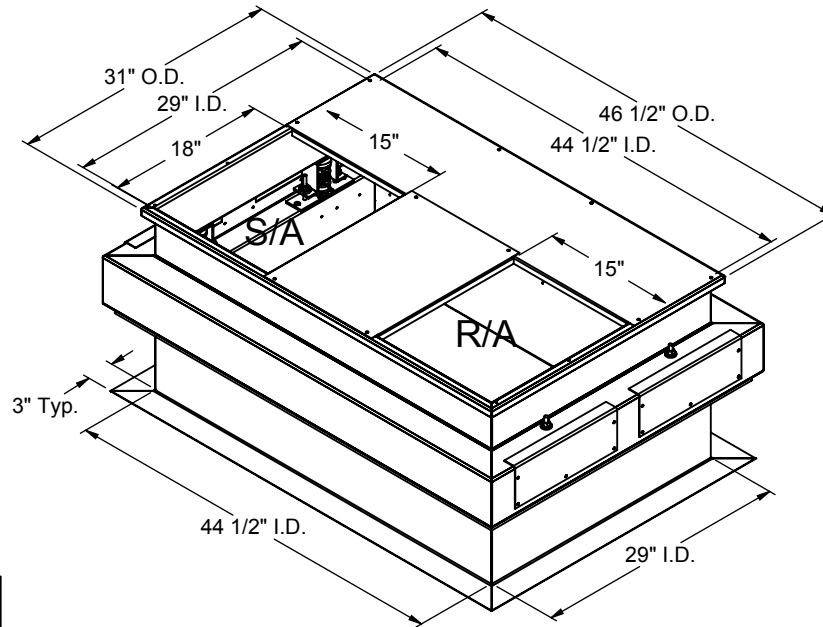

PROFILE DETAIL



3847 WABASH DRIVE
MIRA LOMA, CA 91752

PHONE (951) 685-1101
FAX (619) 872-9799

SUBMITTED TO: _____
 COMPANY: _____
 JOB NAME: _____
 EQUIPMENT: _____
 NOTES: _____

FORM NO:
CBIS-119

PART NUMBER:
CBISLXS SERIES

DATE:
11/2/2018

REV:
-

DRAWN BY:
ALL