

For wood, concrete and steel attachment see Roof Anchorage Detail, Form No. CB-62.

VIBRATION ISOLATION ROOF CURBS FOR YORK UNITS

PG3E, PC3E, PCG4A, PCE4A 24-42
PCG6A, PCE6A, PHE4/6A, PHG4/6A 24-30

FEATURES

- Roof curbs sides and ends are galvanized steel.
- Fully welded construction.
- Gasketing package provided.
- Heat treated wood nailer provided.
- Insulated deck pans provided.
- Pitched curbs and taller curbs are available.

NOTES

- Attach ductwork to roof curb. Flanges of duct rest on top of the curb, Support ductwork below the curb.

PROVENT P/N	A	B	EST. WEIGHT
CBISLXS18**	8"	18"	153 Lbs.
CBISLXS21**	11"	21"	171 Lbs.
CBISLXS24**	14"	24"	189 Lbs.
*Upper shell weight			99 Lbs.

**Note: Spring configuration must be added to part number at time of order. See Price Guide for details.

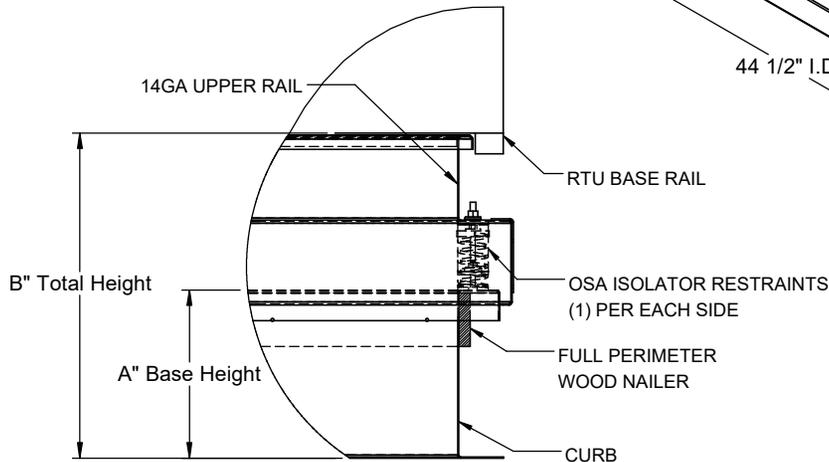
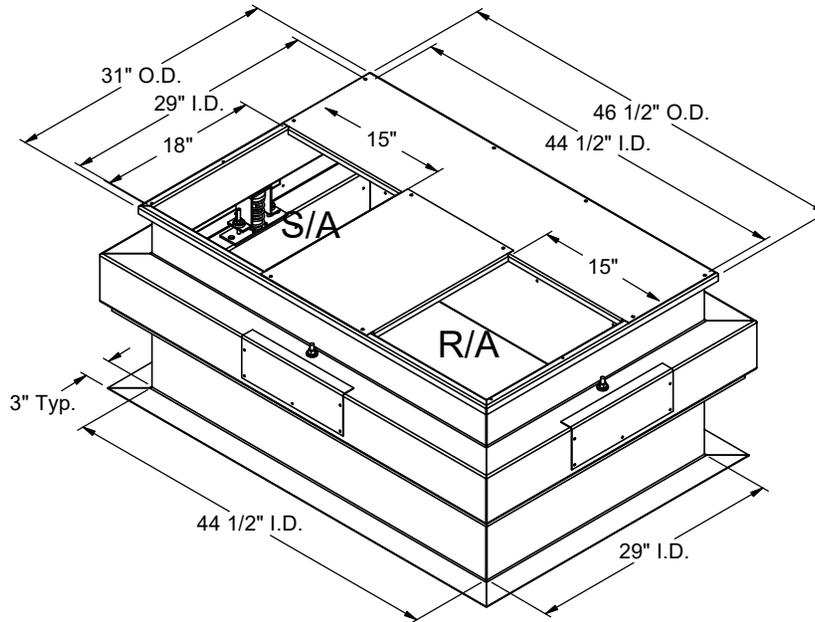

PROFILE DETAIL

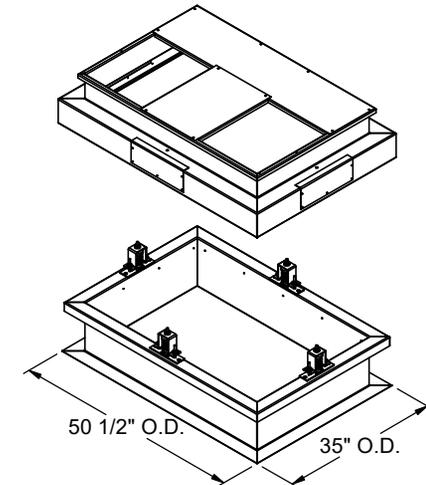

EXPLODED DETAIL



3847 WABASH DRIVE
MIRA LOMA, CA 91752

PHONE (951) 685-1101
FAX (619) 872-9799

SUBMITTED TO: _____
COMPANY: _____
JOB NAME: _____
EQUIPMENT: _____
NOTES: _____

FORM NO:
CBIS-119

PART NUMBER:
CBISLXS SERIES

DATE:
1/13/2025

REV:
2

DRAWN BY:
CNG