

FEATURES

- Fully welded construction.
- 10 Ga. galvanized support frame.
- Estimated weight - 370 Lbs.
- Gasketing package provided.
- Restraints and springs have OSHPD pre-approval, OPA #0070.

VIBRATION ISOLATION FRAME FOR HORIZONTAL YORK UNITS - LOW PROFILE

ZJ/DJ/ZR/WJ/DR/WR/DH/DM 180-300: ZF 210-300: XP 180-240

Unit Model

Power Exhaust?

Provent P/N

ZF 210-300

N/A

CBISHSLM18302

ZJ, ZR 180-300;
XP 180-240

N/A

CBISHSLM18303

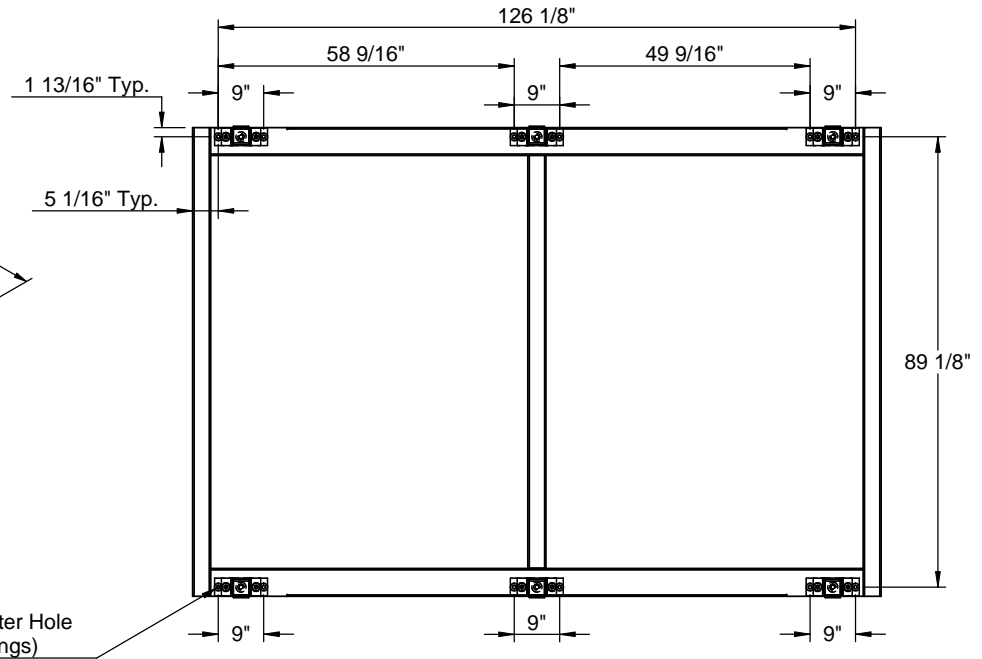
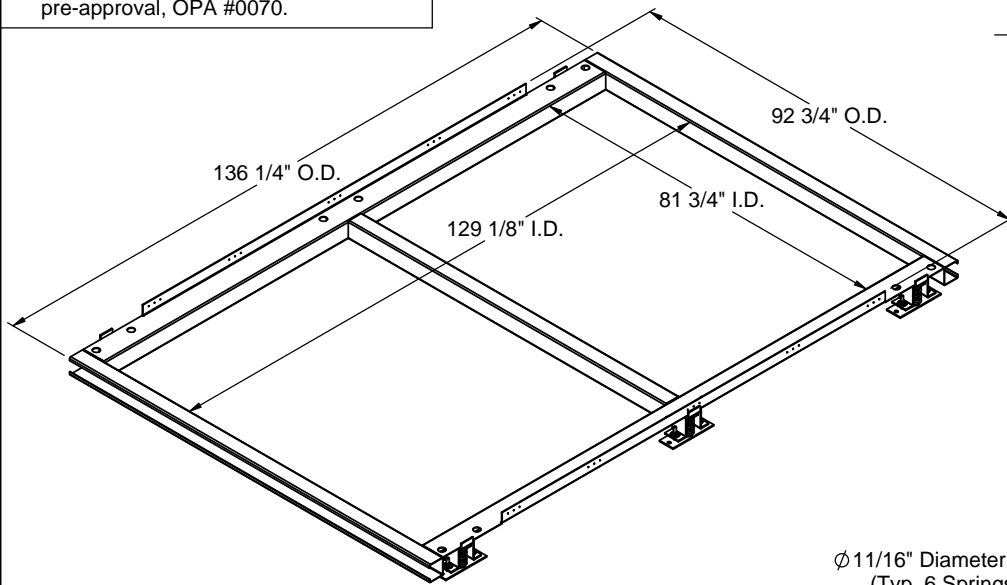

Anchorage Location Detail

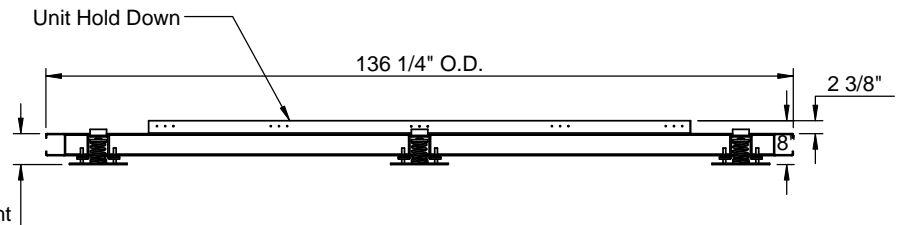
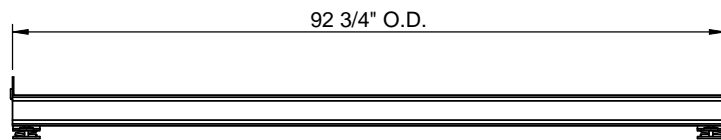

5 5/8" Approximate Oper. Height



3847 WABASH DRIVE
MIRA LOMA, CA 91752

PHONE (951) 685-1101
FAX (619) 872-9799

SUBMITTED TO: _____
COMPANY: _____
JOB NAME: _____
EQUIPMENT: _____
NOTES: _____

FORM NO:
CBISH-112

PART NUMBER:
CBISHSLM1830 - SERIES

DATE:
2/14/2013

REV:
3

DRAWN BY:
CNG