

For wood, concrete and steel attachment see Roof Anchorage Detail, Form No. CB-62.

Welded isolation springs housing are standard. For bolted spring housing, neoprene pads and spring cups see Weldment and Bolting Detail, Form No. CB-61

## VIBRATION ISOLATION ROOF CURBS YORK UNITS

ZT, ZH, ZJ, ZR 037-150  
ZF, XP, ZB 078-150

PROVENT P/N	A	B	EST. WEIGHT
CBISCPRD371518**	8"	18"	365 Lbs
CBISCPRD371521**	11"	21"	387 Lbs
CBISCPRD371524**	14"	24"	410 Lbs

\*\*Note: Spring configuration must be added to part number at time of order

Meets seismic requirements for the following codes:  
CBC 2019  
IBC 2018

### FEATURES

- Roof curbs sides and ends are 14 ga.
- Fully welded construction.
- Gasketing package provided.
- Heat treated wood nailer provided.
- Insulated deck pans provided.
- Pitched curbs and taller curbs are available.
- CalDyn OSHPd pre-approved seismic restraints. (OPM-0401-13), (CQA).

### NOTES

- Attach ductwork to roof curb. Flanges of duct rest on top of the curb, Support ductwork below the curb.
- Thru the curb utilities are available. Contact your York distributor or Provent directly.

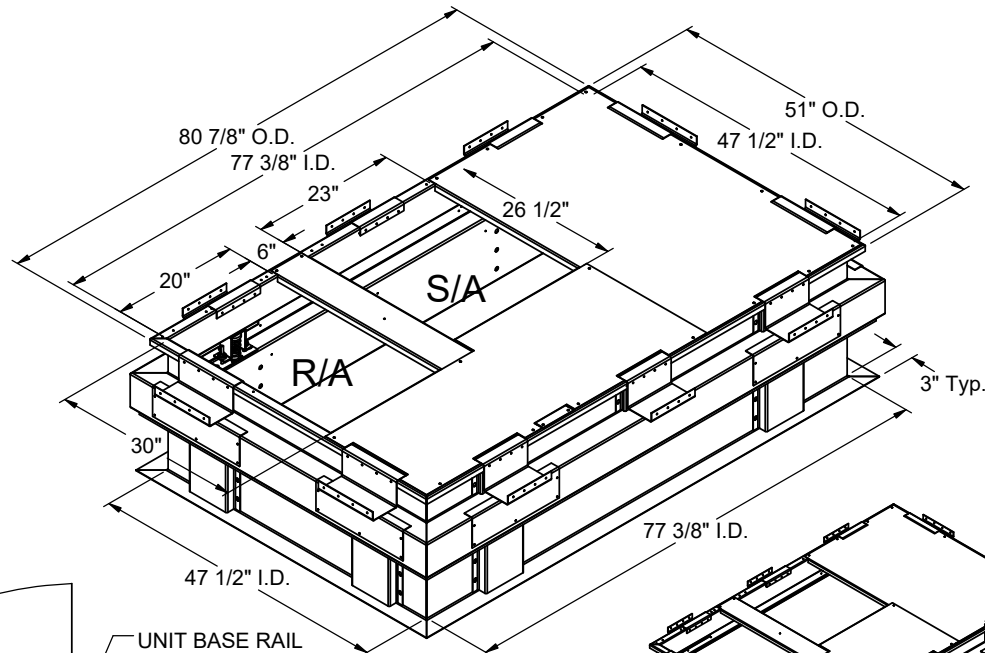

ATTACH TO CURB WITH (4) #10  
TEK SCREWS EACH SIDE

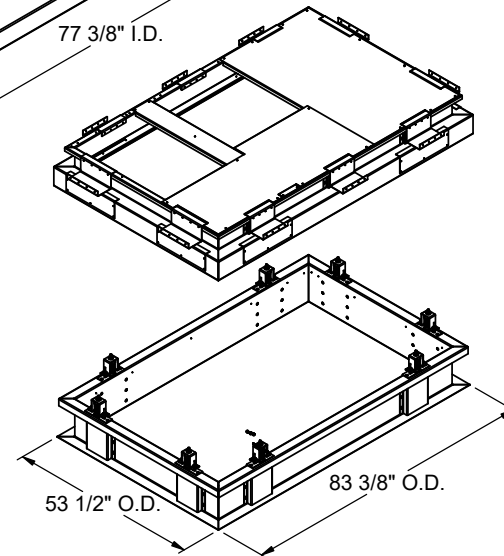
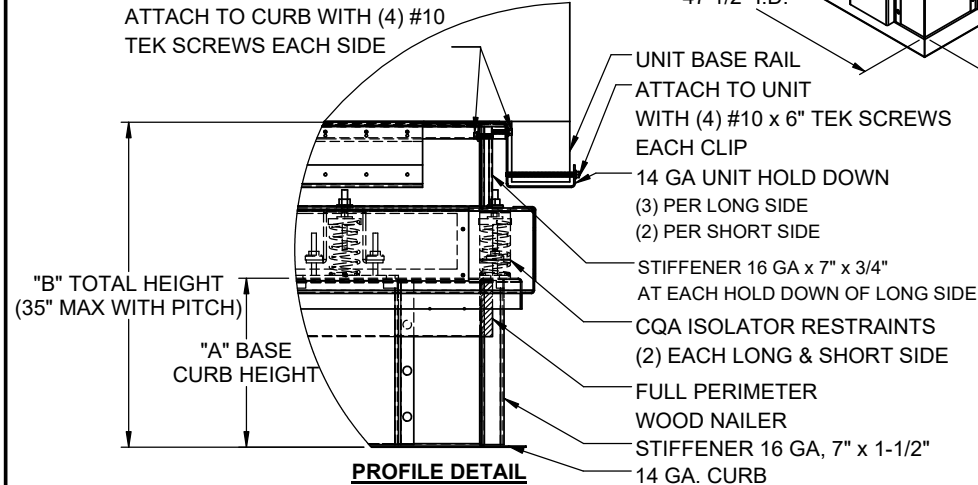

3847 WABASH DRIVE  
MIRA LOMA, CA 91752

PHONE (951) 685-1101  
FAX (619) 872-9799

SUBMITTED TO: \_\_\_\_\_  
COMPANY: \_\_\_\_\_  
JOB NAME: \_\_\_\_\_  
EQUIPMENT: \_\_\_\_\_  
NOTES: \_\_\_\_\_

FORM NO:  
CBISC-04

DATE:  
6/30/2022

PART NUMBER:  
-

REV:  
4

DRAWN BY:  
FMM