

For wood, concrete and steel attachment see Roof Anchorage Detail, Form No. CB-62.

Welded Isolation springs housing are standard. For bolted spring housing, neoprene pads and spring cups see Weldment and Bolting Detail, Form No. CB-61

VIBRATION ISOLATION ROOF CURBS SUNCHOICE UNITS

AV 15-18

| PROVENT P/N | A | B | EST. WEIGHT |
|------------------|-----|-----|-------------|
| CBISCSAV151818** | 8" | 18" | 556 Lbs |
| CBISCSAV151821** | 11" | 21" | 606 Lbs |
| CBISCSAV151824** | 14" | 24" | 656 Lbs |

**Note: Spring configuration must be added to part number at time of order

Meets seismic requirements for the following codes:
CBC 2019
IBC 2018

FEATURES

- Roof curb base 12 ga.
- Roof curb upper rail 14 ga.
- Fully welded construction.
- Gasketing package provided.
- Heat treated wood nailer provided.
- Insulated deck pans provided.
- Pitched curbs and taller curbs are available.
- CalDyn OSHPd pre-approved seismic restraints. (OPM-0401-13), (CQA).

NOTES

- Attach ductwork to roof curb. Flanges of duct rest on top of the curb, Support ductwork below the curb.
- Thru the curb utilities are available. Contact your York distributor or Provent directly.

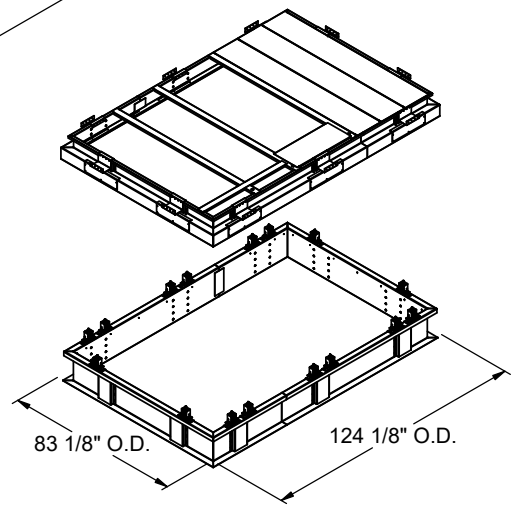
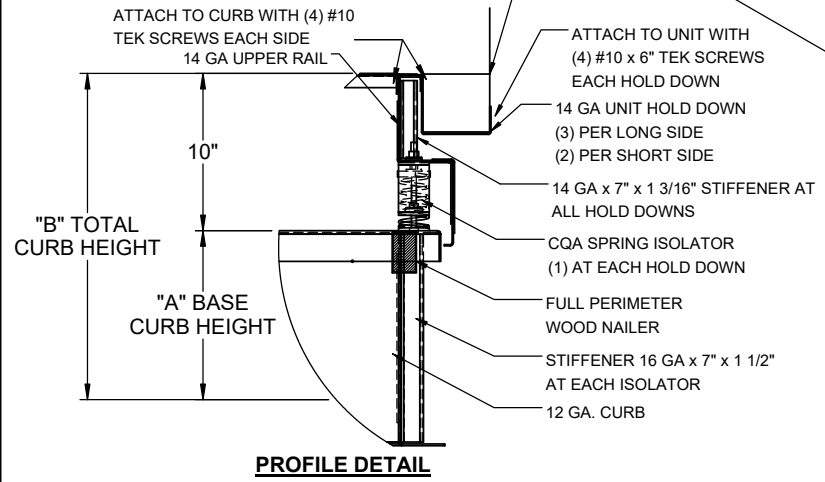
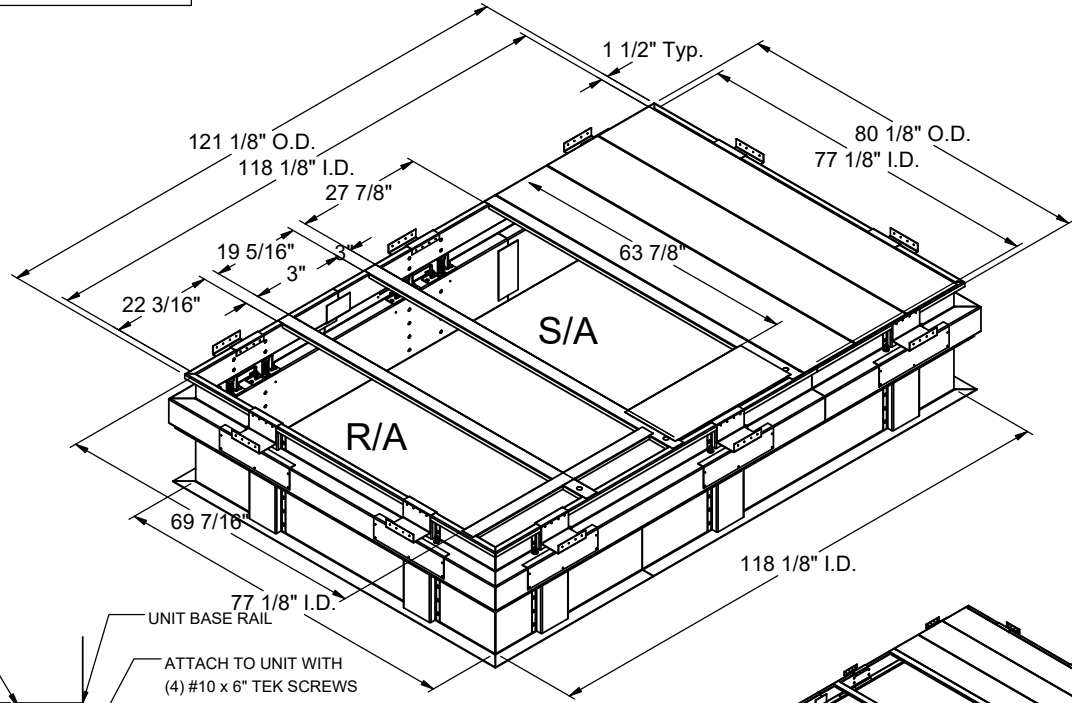

3847 WABASH DRIVE
MIRA LOMA, CA 91752

PHONE (951) 685-1101
FAX (619) 872-9799

SUBMITTED TO: _____
COMPANY: _____
JOB NAME: _____
EQUIPMENT: _____
NOTES: _____

FORM NO:
CBISC-12

DATE:
4/20/2022

PART NUMBER:
-

REV:
2

DRAWN BY:
FMM