

**FEATURES**

- Fully welded construction.
- 10 Ga. galvanized support frame.
- Gasketing package provided.
- Restraints and springs have OSHPD pre-approval, OPA #0070.

**VIBRATION ISOLATION FRAME FOR HORIZONTAL YORK UNITS- LOW PROFILE**

**CHOICE AV20-25, AD20-25, HV15; AE13-15, AW13-15, AH18-20, AL18-20, HV20**

Provent P/N	Weight
CBISHSAV2025	305 Lbs.

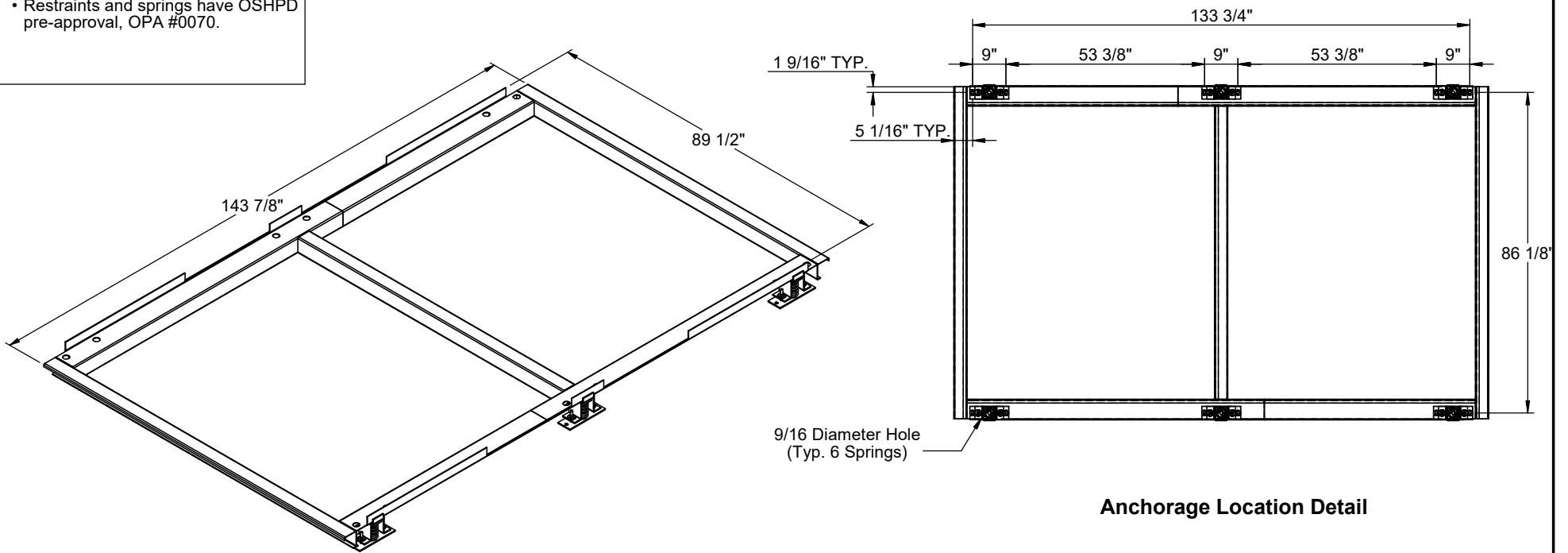

**Anchorage Location Detail**

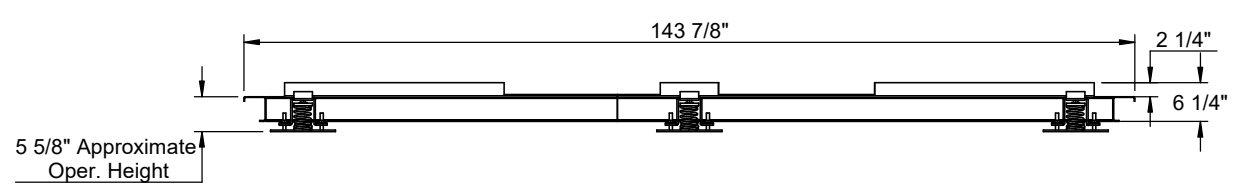
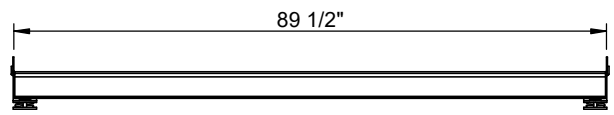

3847 WABASH DR.  
MIRA LOMA, CA 91752

PHONE (951) 685-1101  
FAX (619) 872-9799

SUBMITTED TO: \_\_\_\_\_  
 COMPANY: \_\_\_\_\_  
 JOB NAME: \_\_\_\_\_  
 EQUIPMENT: \_\_\_\_\_  
 NOTES: \_\_\_\_\_

FORM NO: \_\_\_\_\_  
 -  
 DATE: 8/25/2023

PART NUMBER: CBISHSAV2025  
 REV: 1  
 DRAWN BY: JG