

<u>FEATURES</u>
<ul style="list-style-type: none"> • Roof curb perimeter made of galvanized steel. • Gasketing package provided. • Heat treated wood nailer provided. • Corner flanges are pre-threaded for easy bolt on assembly. • Pitched, adjustable pitch/ adjustable height, welded, different height, isolation and calculated curbs are available.
<u>NOTES</u>
<ul style="list-style-type: none"> • Attach ductwork to roof curb. Flanges of duct rest on top of curb. Support ductwork below the curb.

KNOCK-DOWN ROOF CURBS FOR SUNCORE UNITS

AV28, AD 28, AE 18-23, AW 18-23, AH 25, AL 25, HV 25

PROVENT P/N	A	EST. WEIGHT	SEISMIC KIT P/N
CBKDSAV2808**	08"	240 Lbs.	KDKITSAV28
CBKDSAV2811**	11"	275 Lbs.	
CBKDSAV2814**	14"	311 Lbs.	
CBKDSAV2818**	18"	454 Lbs.	

When conforming to CBC 2022 to IBC 2021, include optional seismic kit.
Available for 8" - 18"

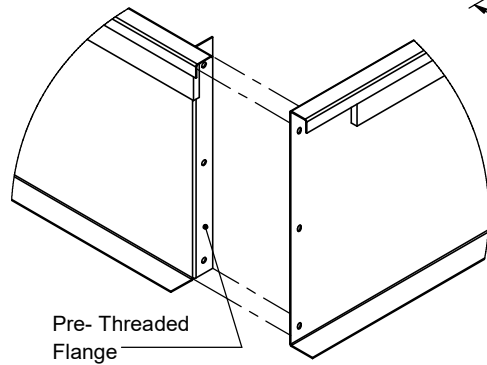
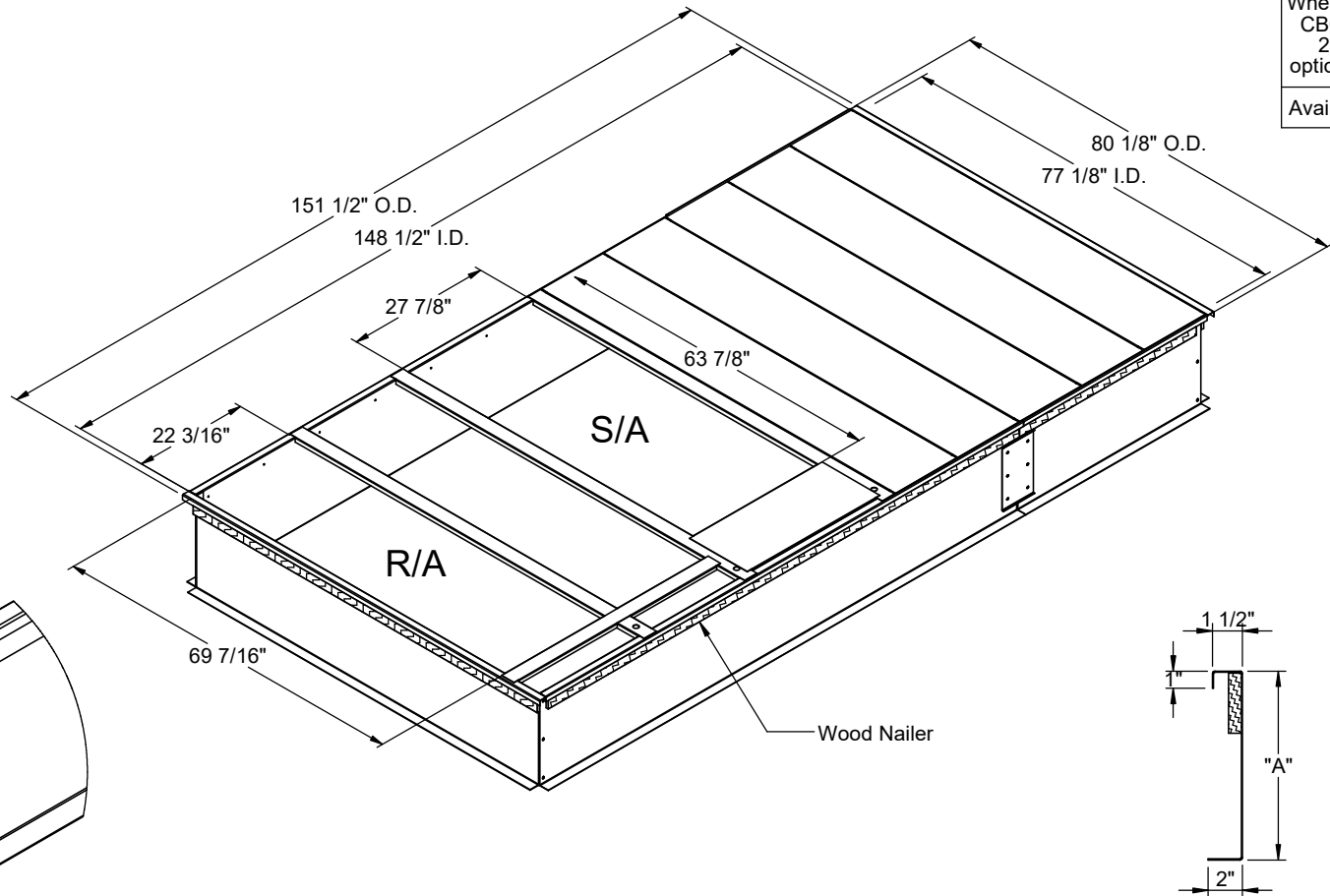

CORNER DETAIL

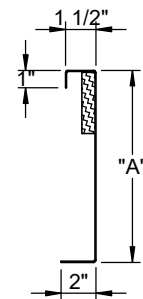

CROSS SECTION DETAIL



3847 WABASH DRIVE
MIRA LOMA, CA 91752

PHONE (951) 685-1101
FAX (619) 872-9799

SUBMITTED TO: _____
COMPANY: _____
JOB NAME: _____
EQUIPMENT: _____
NOTES: _____

FORM NO:

-

DATE:

8/25/2023

PART NUMBER:

CBKDSAV28 SERIES

REV:

3

DRAWN BY:

FMM