

**STEEL ATTACHMENT**

CENTER ON CURB FLANGE. SEE TABLE FOR QUANTITY OF EVENLY SPACED 1/2" Ø A307 BOLTS ATTACHED TO STEEL ANGLE BELOW DECK AT EACH CONNECTION POINT.

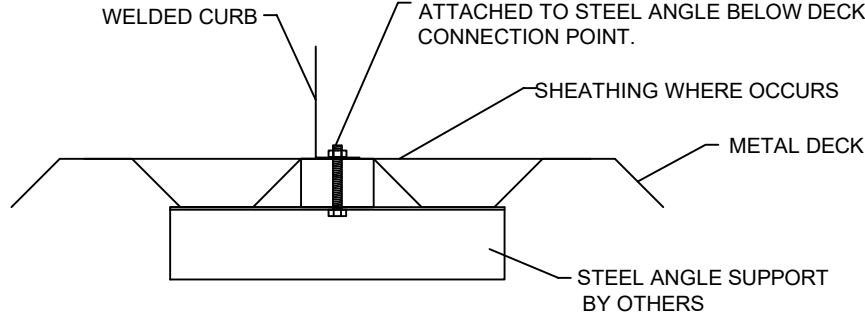

**NO. OF ANCHORAGE BOLTS REQUIRED**

CURB	LONG SIDE	SHORT SIDE
LXS	2 @ 34.5" O.C.	2 @ 19" O.C.
LXL	2 @ 34.5" O.C.	2 @ 29" O.C.
SUN3672	2 @ 60.5" O.C.	2 @ 24.75" O.C.
PRD3715	2 @ 68.88" O.C.	2 @ 39" O.C.
PRS	2 @ 58.88" O.C.	2 @ 28.69" O.C.
PRL	2 @ 72" O.C.	2 @ 41.5" O.C.
SAV1518	3 @ 54.56" O.C.	2 @ 68.13" O.C.
SAV2025	3 @ 61.56" O.C.	2 @ 68.13" O.C.
SAV28	3 @ 69.75" O.C.	2 @ 68.13" O.C.

\* SIX INCHES FROM EACH CORNER EVENLY SPACED.  
\*\* CENTERED.

**ASSUMES:**

CONC SLAB  
f<sub>c</sub>= 4000PSI MINIMUM  
4" MIN THICKNESS  
NORMAL WEIGHT CONCRETE  
MIN. 7-1/4" EDGE DISTANCE

Meets seismic requirements for the following codes:  
CBC 2022  
IBC 2021

**ROOF ANCHORAGE DETAIL**

CBKD Series	CBWC Series
LXS	LXS
LXL	LXL
SUN3672	SUN3672
PRD3715	PRD3715
PRS	PRS
PRL	PRL
SAV1518	SAV1518
SAV2025	SAV2025
SAV28	SAV28

**CONCRETE ATTACHMENT**

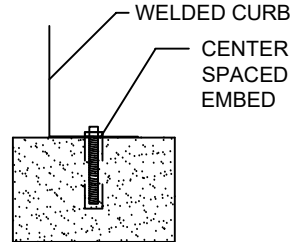

**NO. OF ANCHORAGE BOLTS REQUIRED**

CURB	LONG SIDE	SHORT SIDE
LXS	2 @ 34.5" O.C.	2 @ 19.0" O.C.
LXL	2 @ 34.5" O.C.	2 @ 29" O.C.
SUN3672	2 @ 60.5" O.C.	2 @ 24.75" O.C.
PRD3715	4 @ 22.96" O.C.	2 @ 39" O.C.
PRS	2 @ 58.88" O.C.	2 @ 28.69" O.C.
PRL	3 @ 36" O.C.	2 @ 41.5" O.C.
SAV1518	4 @ 36.38" O.C.	2 @ 68.13" O.C.
SAV2025	4 @ 41.04" O.C.	3 @ 34.06" O.C.
SAV28	5 @ 34.88" O.C.	3 @ 34.06" O.C.

**WOOD ATTACHMENT**

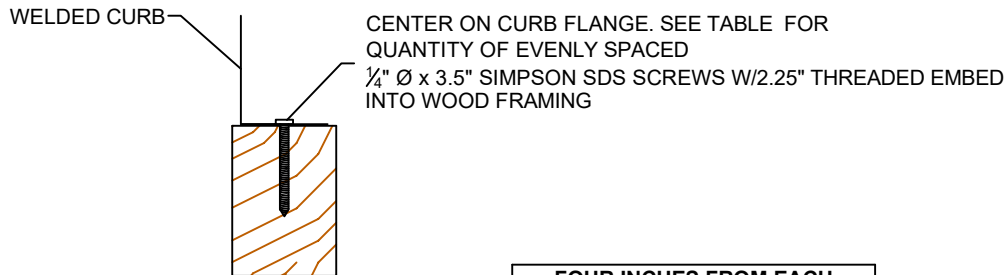

FOUR INCHES FROM EACH CORNER EVENLY SPACED

**NO. OF ANCHORAGE SCREWS REQUIRED**

CURB	LONG SIDE	SHORT SIDE
LXS	4 @ 12.83" O.C.	3 @ 11.5" O.C.
LXL	4 @ 12.83" O.C.	3 @ 16.5" O.C.
SUN3672	4 @ 21.5" O.C.	3 @ 14.38" O.C.
PRD3715	7 @ 12.15" O.C.	5 @ 10.75" O.C.
PRS	4 @ 20.96" O.C.	3 @ 16.35" O.C.
PRL	6 @ 15.2" O.C.	4 @ 15.17" O.C.
SAV1518	6 @ 22.63" O.C.	5 @ 18.03" O.C.
SAV2025	7 @ 21.19" O.C.	5 @ 18.03" O.C.
SAV28	8 @ 20.5" O.C.	5 @ 18.03" O.C.



3847 WABASH DRIVE  
MIRA LOMA, CA 91725

PHONE (951) 685-1101  
FAX (619) 872-9799

SUBMITTED TO: \_\_\_\_\_  
COMPANY: \_\_\_\_\_  
JOB NAME: \_\_\_\_\_  
EQUIPMENT: \_\_\_\_\_  
NOTES: \_\_\_\_\_

FORM NO:  
CB-60

DATE:  
8/28/2023

REV:  
10

DRAWN BY:  
FMM