

<b>FEATURES</b>	<b>KNOCK-DOWN ROOF CURBS FOR YORK UNITS</b>	<b>General Table</b>			<b>SEISMIC KIT P/N</b>	
		<b>PROVENT P/N</b>	<b>A</b>	<b>EST. WEIGHT</b>		
		ZF 180	CBKDSL18008	8"	115 Lbs.	KDKITSLU180
			CBKDSL18011	11"	129 Lbs.	
<ul style="list-style-type: none"> <li>• Roof curb perimeter made of galvanized steel.</li> <li>• Gasketing package provided.</li> <li>• Heat treated wood nailer provided.</li> <li>• Corner flanges are pre-threaded for easy bolt on assembly.</li> <li>• Pitched, adjustable pitch/ adjustable height, welded, different height, isolation and calculated curbs are available.</li> </ul>		CBKDSL18014	14"	144 Lbs.	Meets seismic requirements for the following codes: CBC 2019 IBC 2018	

**NOTES**

- Attach ductwork to roof curb. Flanges of duct rest on top of curb. Support ductwork below the curb.

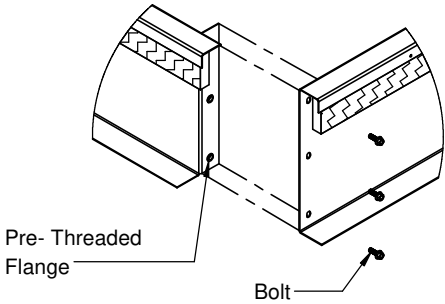
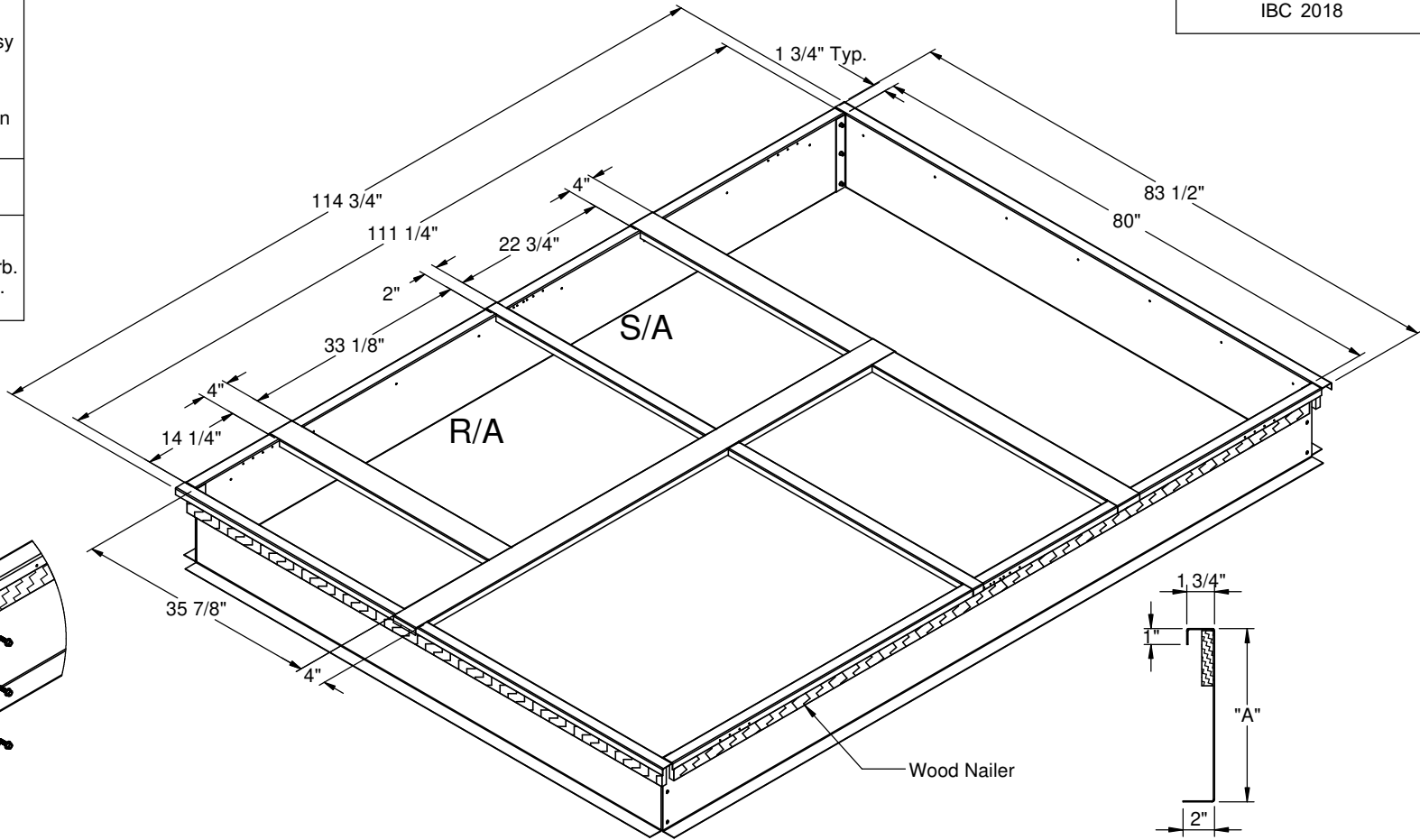

**CORNER DETAIL**

**CROSS SECTION DETAIL**

	3847 WABASH DR. MIRA LOMA, CA 91725	SUBMITTED TO: _____	FORM NO: CBKD-104	PART NUMBER: CBKDSL180 SERIES
	PHONE (951) 685-1101 FAX (619) 872-9799	COMPANY: _____	DATE: 1/24/2020	REV: 1
		JOB NAME: _____		DRAWN BY: JG
		EQUIPMENT: _____		
		NOTES: _____		